



**ANNOVI
REVERBERI**®
The Power of Experience



CATALOGO INDUSTRIAL
DIVISION *CATALOGUE*

INDICE INDEX

Indice / Index

276 SERIES	P 12
414 SERIES	P 20
320 SERIES	P 30
132 SERIES	P 36
178 SERIES	P 42
322 SERIES	P 52
228 SERIES	P 60
402 SERIES	P 76
298 SERIES	P 84
194 SERIES	P 88
538 SERIES	P 110
366 SERIES	P 112
418 SERIES	P 126
STAINLESS STEEL	P 138
ADDITIONAL ELECTRIC MOTOR	P 146
WOBBLE PLATE	P 152

<i>Accessori Accessories</i>	P 164
------------------------------	-------

AR GROUP	P 174
----------	-------





*Ufficio di Corrado Reverberi
Fondatore*

Annovi Reverberi: oltre 60 anni di eccellenza italiana.

Un supermercato di Parigi, un autolavaggio di Los Angeles, un campo di grano a sud di Kiev: un'unica cosa in comune, un prodotto che deriva dal cuore dell'Italia, una pompa Annovi Reverberi. Fondata nel 1958 da Corrado Reverberi, Annovi Reverberi è ancora oggi un'azienda italiana di famiglia, una realtà metalmeccanica fortemente legata al territorio, fatta di persone idee e progetti innovativi. Un esempio di imprenditoria italiana basata su esperienza, artigianalità e innovazione. Un marchio riconosciuto in tutto il mondo come simbolo di massima qualità e saper fare italiano.

Oltre 60 anni di storia che hanno visto il gruppo Annovi Reverberi crescere notevolmente e diventare leader in tre settori di riferimento: agricoltura con la produzione di pompe a membrana; industria attraverso il successo delle pompe a pistoncini AR e infine negli anni '90 cleaning con lo sviluppo di idropulitrici e aspiratori.

Annovi Reverberi: More than 60 years of Italian excellence

A supermarket in Paris, a car wash in Los Angeles, a wheat field south of Kiev: the same thing in common; a product from the heart of Italy, an Annovi Reverberi pump. Founded in 1958 by Corrado Reverberi, Annovi Reverberi is still an Italian family-owned company, a mechanical engineering reality strongly linked to the territory and made up of people, ideas and innovative projects.

An example of Italian entrepreneurship based on experience, innovation and passion.

A brand recognized all over the world as a symbol of top quality and Italian know-how. It's more than 60 year history has seen the Annovi Reverberi group grow considerably and become a leader in three sectors of reference: agriculture with the production of diaphragm pumps; industry through the success of AR piston pumps and, finally, in the 90s, cleaning with the development of high-pressure washers and vacuum cleaners.



*New headquarters
Modena, Italy*

Arte

Siamo da sempre consapevoli di come l'arte e la bellezza siano potenti mezzi per creatività ed innovazione che si trasmettono anche attraverso gli spazi di lavoro.

Art

We know how art and beauty are powerful means to channel creativity and innovation which can be transmitted throughout our workspace.



*"Cavallo con Sfera e Numeri"
di Mimmo Paladino.
"Horse with Sphere and
Numbers" by Mimmo Paladino.*

Made in Annovi Reverberi

"Made in Annovi Reverberi" è sinonimo di innovazione tecnologica, qualità, elevate prestazioni e sostenibilità. Dietro ogni prodotto Annovi Reverberi ci sono anni di costante ricerca e passione, ogni pompa a pistoni è il risultato della più alta qualità italiana unita alle più avanzate tecnologie produttive.

Per ogni industria la sua pompa a pistoni

Innovazione tecnologica e un nuovo machining center all'avanguardia consentono ad Annovi Reverberi il raggiungimento della massima qualità e prestazioni sempre più elevate. L'attenzione per il dettaglio e componenti di altissima qualità lavorati direttamente in azienda sono gli ingredienti principali per sviluppare una gamma completa di pompe a pistoni caratterizzate da diverse prestazioni tecniche per garantire non solo il lavaggio ad acqua ma anche altre applicazioni come, ad esempio, misting, osmosi inversa e abbattimento polveri.

Le pompe a pistoni AR sono compatte, sempre più silenziose, dotate di pistoni in ceramica per garantire una maggiore durata e necessitano una manutenzione minima data la loro affidabilità. Inoltre possono essere associate a diversi accessori e allestite con motori idraulici, a scoppio e elettrici tra cui i motori Made in Italy Ravel, azienda parte del gruppo.

Made in Annovi Reverberi

"Made in Annovi Reverberi" is a synonym of technological innovation, quality, Italian performance and corporate social responsibility. Behind every Annovi Reverberi product there are years of research, passion and patience, every pump is the result of the highest Italian quality combined with the most advanced production technologies.

For every industry the piston pump you need

Technological innovation and a new machining center allow Annovi Reverberi to achieve the highest quality standards and ever higher performance. The attention to detail and high quality components finished directly inside the company have been the main factors in developing a full range of piston pumps characterized by different technical characteristics suitable not only for cleaning but also for other applications such as misting, reverse osmosis and dust suppression. AR piston pumps are compact, silent running, equipped with ceramic plungers to guarantee longer life and require minimal maintenance due to their reliability. In addition, AR pumps can be associated with various accessories and equipped with hydraulic, petrol and electric engines including the Made in Italy Ravel electric motors, part of Annovi Reverberi Group.



Sostenibilità: Non un concetto ma vere e proprie azioni per raggiungere la sostenibilità sociale, economica e ambientale.

Miglioramento costante dei processi per ridurre l'impatto ambientale, riciclo totale delle acque reflue, riciclo totale dei rifiuti industriali, controllo ad alta efficienza energetica della nuova sala prove, sviluppo di prodotti sempre più sostenibili e ad alta efficienza, reinvestimento degli utili nell'economia locale sono solo alcune delle azioni intraprese da Annovi Reverberi per aumentare la sostenibilità.

Sustainability: Not a concept but real actions to achieve social economic and environmental sustainability.

Processes improvements to reduce environmental impact, total recycling of waste water, total recycling of industrial waste, high energy efficiency control of the new testing room, sustainable and high efficiency product development, profit reinvestment in local economy; these are only some of the actions taken by Annovi Reverberi in order to increase sustainability.



PLUS

Testa pompa in ottone forgiato con disegno per alta resistenza.

Forged brass pump head, designed for strength.

Valvole di aspirazione e mandata con passaggi acqua maggiorati.

Suction and delivery valves with larger water passages.

Pistoni in ceramica di grosso spessore per una maggiore durata.

Extra-thick ceramic plungers for greater durability.

Sistema di tenuta a doppia guarnizione.

Double gasket sealing system.

Anelli tenuta olio con doppio labbro.

Double lip oil seals.

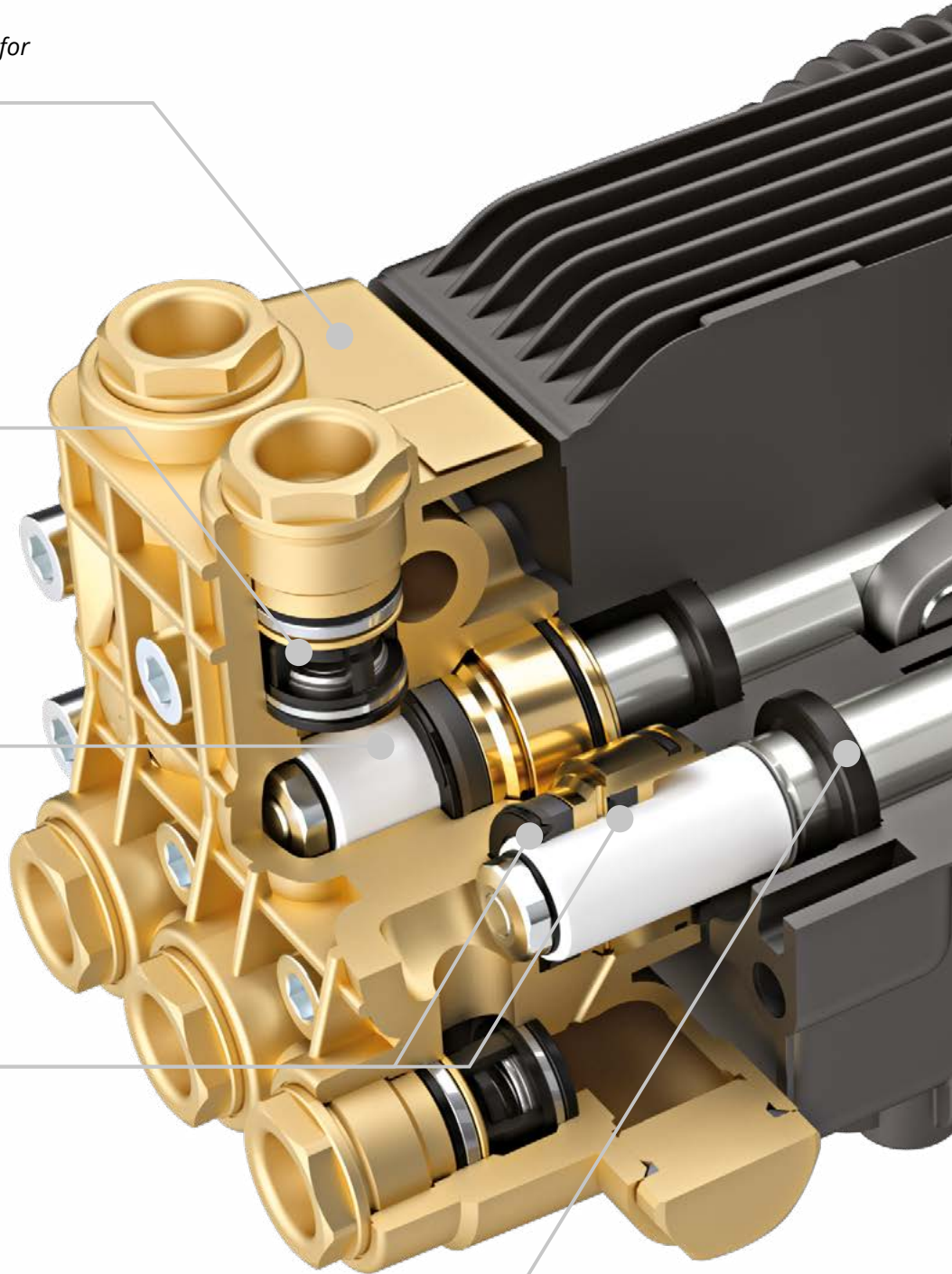



Corpo pompa di disegno robusto e con elevata alettatura per un miglior smaltimento del calore.

Ruggedly designed crankcase with deep fins for better cooling.

Cuscinetti a rulli conici di qualità e sovradimensionati.

Top quality, oversized tapered roller bearings.

Albero sovradimensionato e con terminale lungo per una migliore trasmissione della coppia.

Oversized shaft with long end section for better torque transmission.

Bielle sovradimensionate e realizzate con una speciale lega antifrizione. Scomponibili in due parti per una migliore manutenzione.

Oversized connecting-rods in a special low-friction alloy. Split into two parts for easier maintenance.

Pistoni di guida sovradimensionati e rettificati per una riduzione dell'attrito durante lo scorrimento ed una migliore tenuta olio.

Oversized, piston guides for smoother stroke and better oil seal performance.



INDICE INDEX

Indice / Index

276 SERIES	P 12
414 SERIES	P 20
320 SERIES	P 30
132 SERIES	P 36
178 SERIES	P 42
322 SERIES	P 52
228 SERIES	P 60
402 SERIES	P 76
298 SERIES	P 84
194 SERIES	P 88
538 SERIES	P 110
366 SERIES	P 112
418 SERIES	P 126
STAINLESS STEEL	P 138
ADDITIONAL ELECTRIC MOTOR	P 146
WOBBLE PLATE	P 152

Accessori <i>Accessories</i>	P 164
-------------------------------------	-------

AR GROUP	P 174
-----------------	-------

276 SERIES

RS
RSS
RSV
HRS

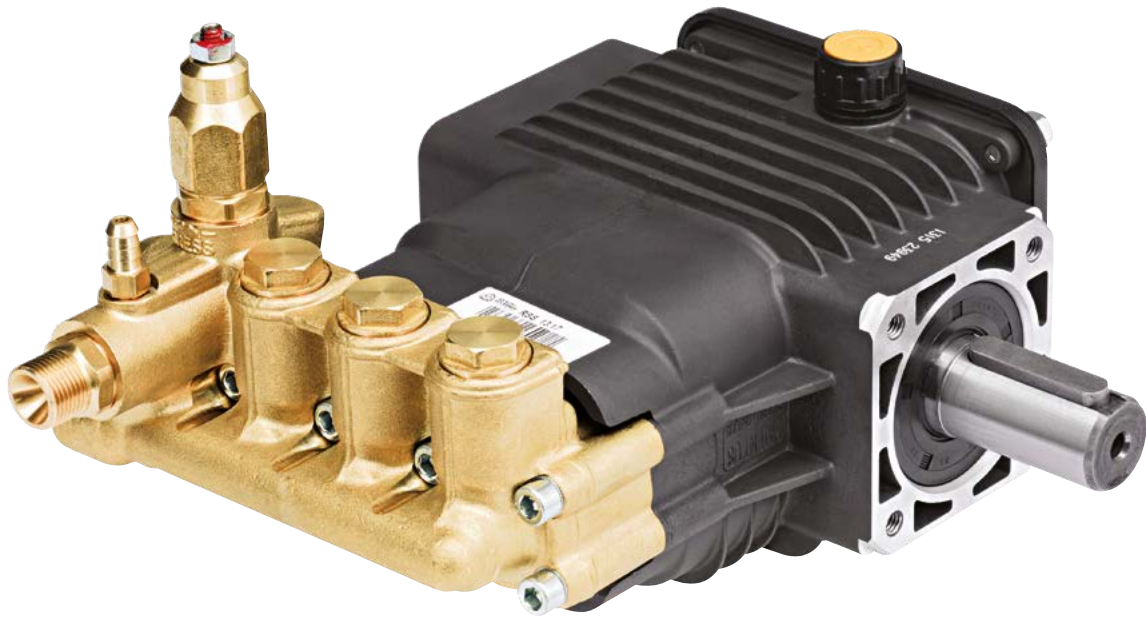

Corpo in alluminio pressofuso.

Coperchio laterale chiuso.

Bielle in lega zinco- alluminio pressofuso oppure in bronzo.

Testa in ottone stampato con valvola di regolazione integrata.

Pistoni acciaio inox con copertura in ceramica.

Crankcase in pressure die-cast aluminium alloy.

Closed side cover.

Connecting rods in die-cast zinc-aluminium alloy. Bronze connecting rods available.

Pump head in forged brass with integrated pressure regulating valve.

Plungers in ceramic-coated stainless steel.

276 Series

POMPA ALBERO MASCHIO Solid shaft pump

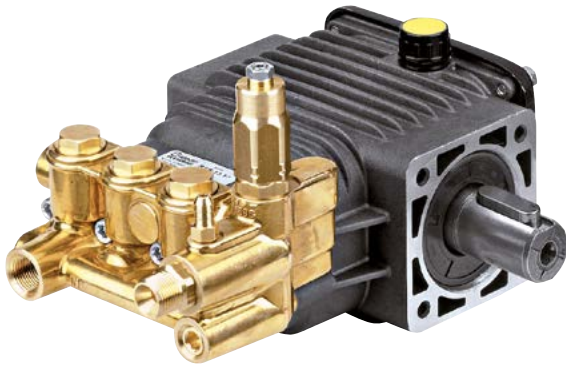

idropultrici
pressure
washers

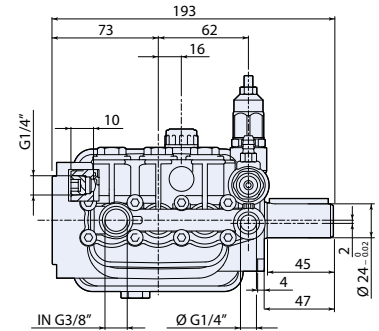
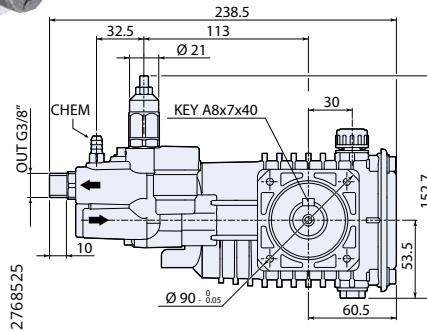

N version

Flangiatura compatibile XT N.
XT N flange type.

MOD	COD	MAX	MAX						
		l/min	gpm	bar	psi	hp	kW	N° giri/1'	kg
RS 1450rpm Nversion Ø24mm									
RS 11.11 N	23084	11	2,90	110	1600	3	2,2	1450	7
RS 11.14 N	24543	11	2,90	140	2000	4	3	1450	7
RS 11.18 N	23616	11	2,90	180	2600	5,5	4	1450	7
RS 13.17 N	23160	13	3,43	170	2500	5,5	4	1450	7
RS 15.15 N	23161	15	3,96	150	2200	5,5	4	1450	7



testa in
ottone
brass
head



bielle in
alluminio
aluminium
connecting-rods



POMPA ALBERO MASCHIO Solid shaft pump



idropultrici
pressure
washers

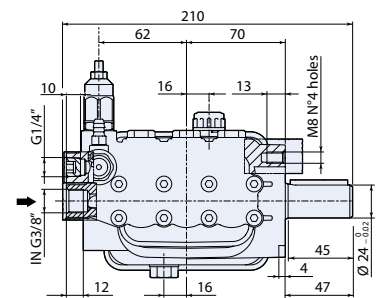
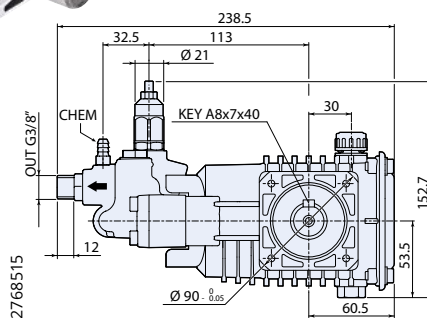

N version

Flangiatura compatibile XT N.
XT N flange type.

MOD	COD	MAX	MAX						
		l/min	gpm	bar	psi	hp	kW	N° giri/1'	kg
RSS 2800rpm Nversion Ø24mm									
RSS 11.14 N	27186	11	2,90	140	2000	4	3	2800	7
RSS 11.17 N	25187	11	2,90	170	2500	5,5	4	2800	7
RSS 13.17 N	23949	13	3,43	170	2500	5,5	4	2800	7
RSS 15.15 N	23182	15	3,96	150	2200	5,5	4	2800	7



testa in
ottone
brass
head



bielle in
alluminio
aluminium
connecting-rods



276 series

POMPA ALBERO CAVO Hollow shaft pump



idropulitrici
pressure
washers

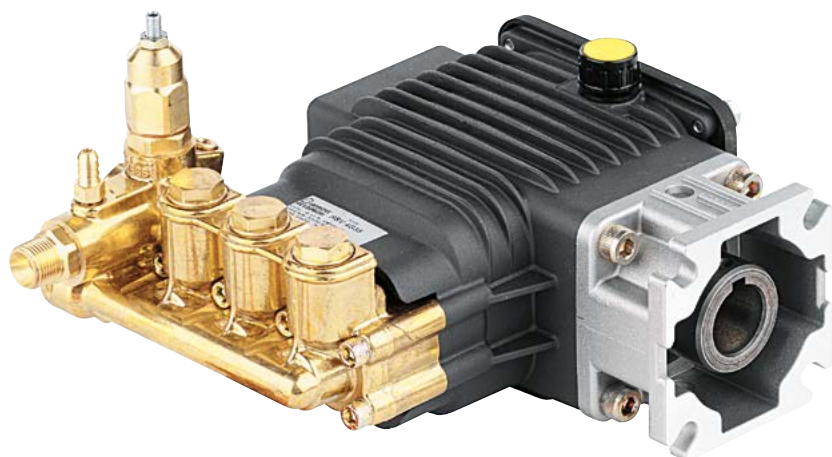

Su richiesta
On request

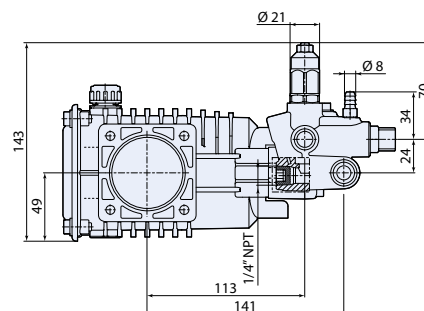
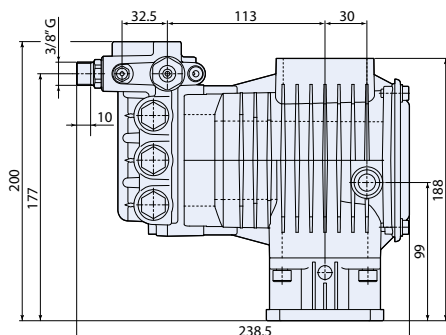
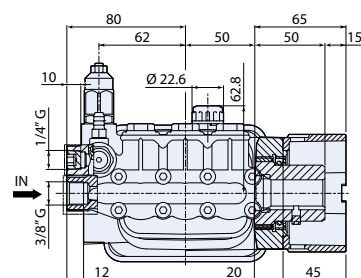
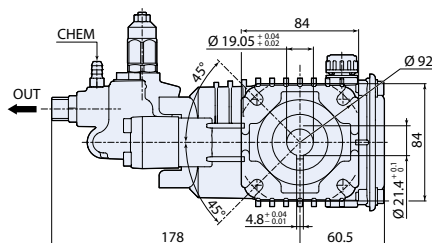

2768501

D version + F25

MOD	COD	MAX	MAX		NET				
		l/min	gpm	bar	psi	hp	kW	N° giri/1'	kg
RSV 3400rpm Dversion + F25 Ø3/4"									
RSV 2.5G25 D + F25	25918	9,5	2,5	170	2500	4,5	3,3	3400	7
RSV 3G25 D + F25	23473	11,4	3	170	2500	5	3,7	3400	7

Per motori scoppio flangia Ø3/4" SAE J609a. Flangia inclusa.
For gasoline engine flange Ø3/4" SAE J609a. Flange included.



testa in
ottone
brass
head



bielle in
alluminio
aluminium
connecting-rods



idropulitrici
pressure
washers

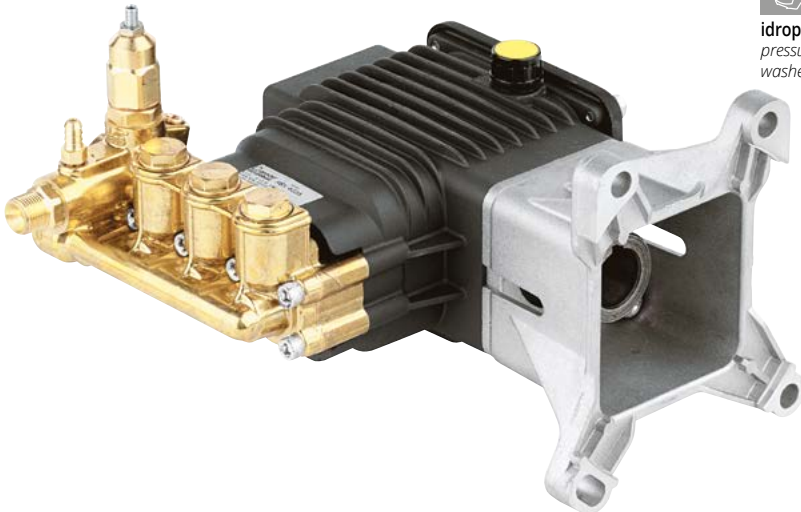

Su richiesta
On request

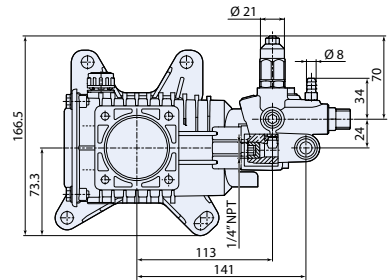
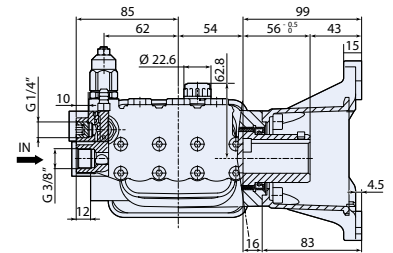
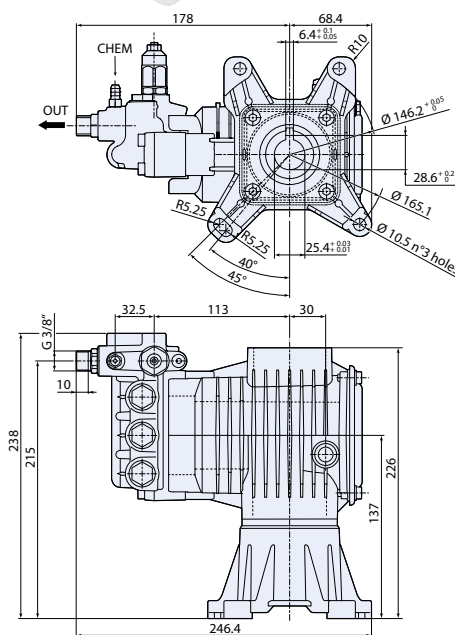

2768500

D version + F40

MOD	COD	MAX	MAX						
		l/min	gpm	bar	psi	hp	kW	N° giri/1'	kg
RSV 3400rpm Dversion + F40 Ø1"									
RSV 3G30 D + F40	25552	11,4	3	205	3000	5,5	4	3400	7
RSV 3G35 D + F40	23856	11,4	3	240	3500	7,5	5,5	3400	7,5
RSV 3.5G35 D + F40	27187	13,2	3,5	240	3500	10	7,5	3400	7,5
RSV 4G30 D + F40	25795	15,1	4	205	3000	7,5	5,5	3400	7
RSV 4G35 D + F40	27094	15,1	4	240	3500	10	7,5	3400	7,5
RSV 4G40 D + F40	24582	15,1	4	275	4000	11	8,2	3400	7,5

Per motori scoppio flangia Ø1" SAE J609a. Flangia inclusa.
For gasoline engine flange Ø1" SAE J609a. Flange included.



testa in
ottone
brass
head



bielle in
bronzo
bronze
connecting-rods



bielle in
alluminio
aluminium
connecting-rods



276 series

POMPA ALBERO CAVO Hollow shaft pump



idropultrici
pressure
washers

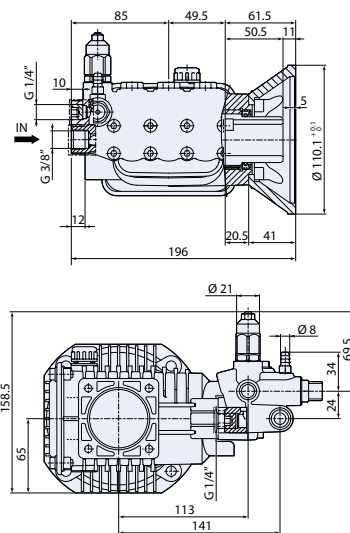
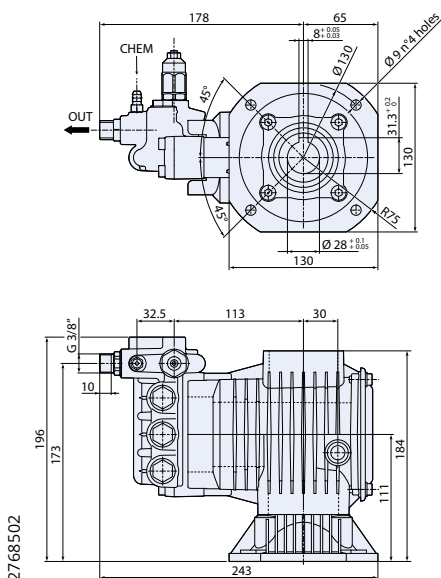
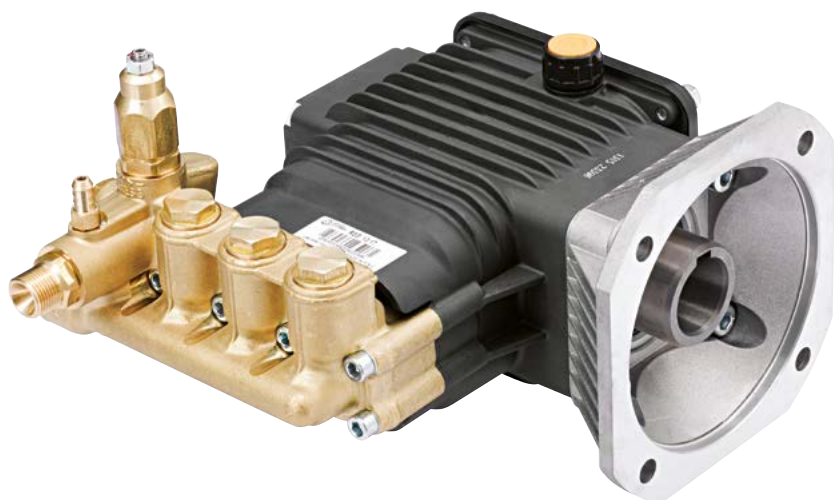

C version + F16

MOD	COD	MAX	MAX		NET				
		l/min	gpm	bar	psi	hp	kW	N° giri/1'	kg
RSS 2800rpm Cversion + F16 Ø28mm									
RSS 11.14 C + F16	27184	11	2,90	140	2000	4	3	2800	7
RSS 11.17 C + F16	27185	11	2,90	170	2500	5,5	4	2800	7
RSS 13.17 C + F16	23396	13	3,43	170	2500	5,5	4	2800	7
RSS 15.15 C + F16	26306	15	3,96	150	2200	5,5	4	2800	7



testa in
ottone
brass
head



bielle in
alluminio
aluminium
connecting-rods

Flangia F16 per motori elettrici B14 Gr.100-112 IEC34-7, 2 poli 50Hz. Flangia inclusa.
F16 flange for electric motor B14 100-112 IEC34-7, 2 poles 50Hz. Flange included.



idropultrici
pressure
washers

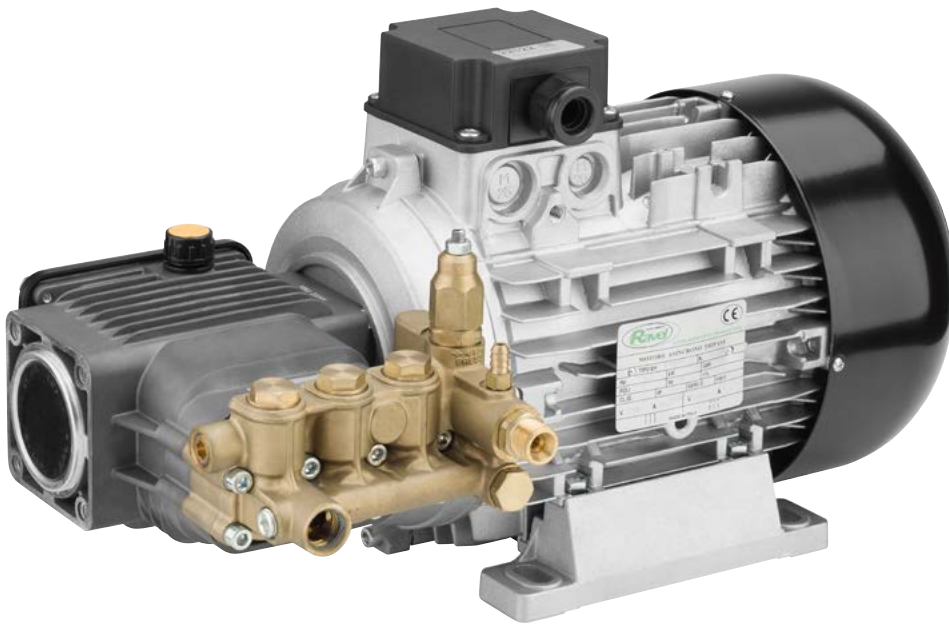

GR. 100 motor hollow shaft

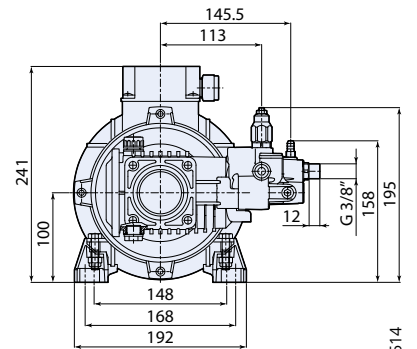
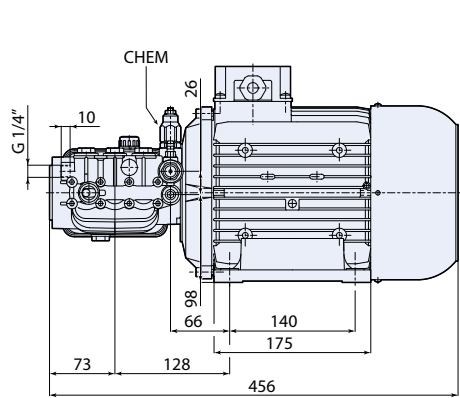

2768514

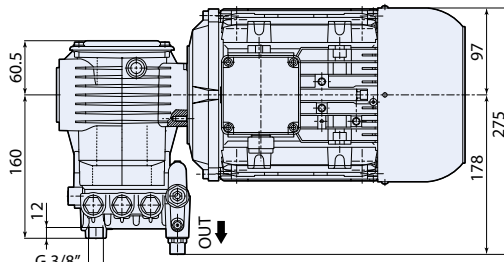

MOD	COD	MAX		MAX				⚡		KG NET				
		1 ~	3 ~	l/min	gpm	bar	psi	hp	kW	N° giri/1'	V 1-50Hz	V 3-50Hz	Gr.	kg
HRS 1450rpm														
HRS 11.11 REG EM	22117	-	11	2,90	110	1600	3	2,2	1450	230	-	100	30	
HRS 11.17 REG ET	-	22120	11	2,90	170	2500	5	3,7	1450	-	230/400	100	30	
HRS 13.17 REG ET	-	22121	13	3,43	170	2500	5,5	4	1450	-	230/400	100	30	
HRS 15.15 REG ET	-	22122	15	3,96	150	2200	5,5	4	1450	-	230/400	100	30	



testa in
ottone
brass
head



bielle in
alluminio
aluminium
connecting-rods



frequenza
motore
motor
frequency



frequenza
motore
motor
frequency



JR
JRA
JRS
JRV
JR-M
JRA-M
HJR
HJRS
HJR-M

414 SERIES

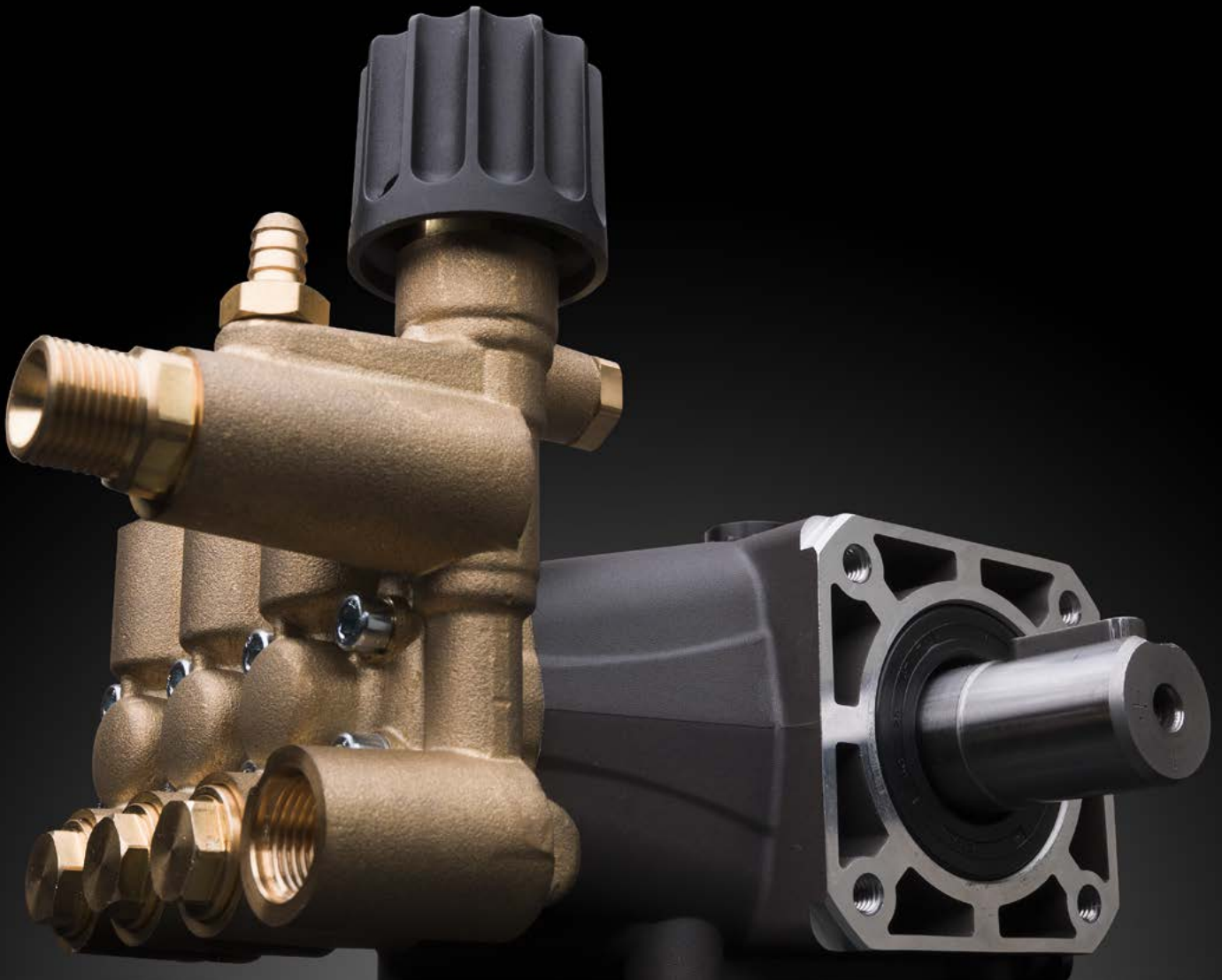



DESIGN FOR PERFORMANCE

CORPO COMPATTO. PRESTAZIONI ELEVATE.

Una gamma completa di pompe a pistoni per garantire diverse applicazioni: JR, JRA, JRS ideali per l'utilizzo su idropultrici grazie alla loro dimensione compatta.

JR-M, JRA-M studiate appositamente per l'applicazione misting.

Disponibile la versione con TSS integrato e in associazione a motori elettrici.

COMPACT BODY HIGH-PERFORMANCE PUMP

A full range of performance piston pumps for different applications: JR, JRA, JRS perfect for high-pressure washers because of its compact dimensions.

JR-M, JRA-M studied in detail for misting application.

Available TSS version and electric motor-pump units.



414 SERIES

JR
JRA
JRS
JRV
JR-M
JRA-M

HJR
HJRS
HJR-M

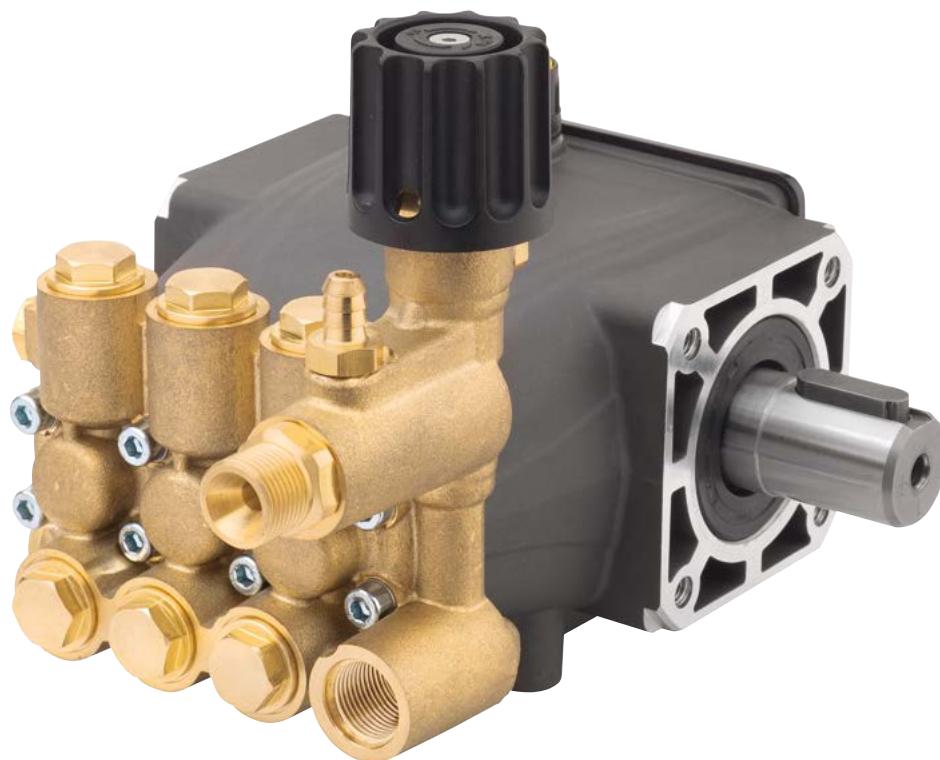

Corpo in alluminio pressofuso.

Coperchio laterale chiuso o con livello olio.

Bielle in lega zinco- alluminio pressofuso.

Testa in ottone stampato o in lega d'alluminio pressofuso con valvola di regolazione integrata.

Pistoni acciaio inox con copertura in ceramica.

Crankcase in pressure die-cast aluminium alloy.

Side cover closed or incorporated with oil sight glass.

Connecting rods in die-cast zinc-aluminium alloy.

Pump head in forged brass or die-cast aluminium alloy with integrated pressure regulating valve.

Plungers in ceramic-coated stainless steel.

414 Series

POMPA ALBERO MASCHIO
Solid shaft pump



idropultrici
pressure
washers

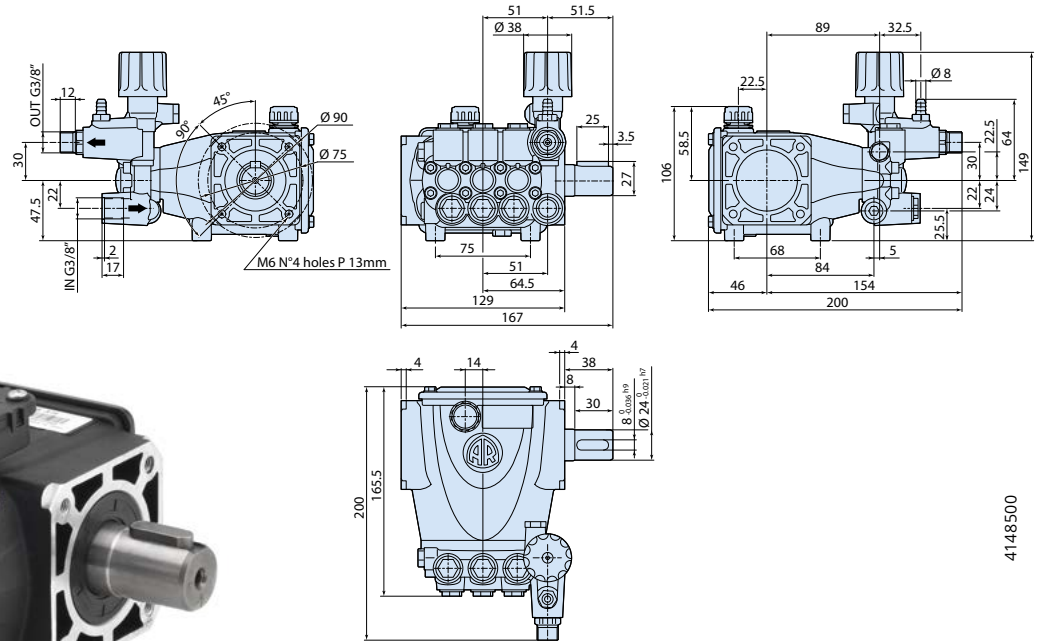

TSS version

4148500

N version

MOD	COD	MAX	MAX							
		l/min	gpm	bar	psi	hp	kW	N° giri/1'	kg	
JR 1450rpm Nversion Ø24mm										
JR 8.12 N TA	27684	8	2,11	120	1740	2,5	1,8	1450	3,5	
JR 8.12 N TSS TA	27685	8	2,11	120	1740	2,5	1,8	1450	3,5	
JRA 1750 rpm Nversion Ø24mm										
JRA 2.5G17 N TA	27686	9,5	2,5	120	1740	3	2,2	1750	3,5	
JRS 2800rpm Nversion Ø24mm										
JRS 8.14 N TA	27592	8	2,11	140	2000	3	2,2	2800	3,5	
JRS 8.14 N TSS TA	27593	8	2,11	140	2000	3	2,2	2800	3,5	
JRS 10.14 N TA	27594	10	2,64	140	2000	4	3	2800	3,5	
JRS 10.14 N TSS TA	27595	10	2,64	140	2000	4	3	2800	3,5	
JRS 14.12 N TA	27596	14	3,7	120	1740	4,4	3,3	2800	3,5	
JRS 14.12 N TSS TA	27597	14	3,7	120	1740	4,4	3,3	2800	3,5	

NEW

TSS
Total Stop
SYSTEM



testa in
alluminio
aluminium
head



bielle in
alluminio
aluminium
connecting-rod



idropultrici
pressure
washers

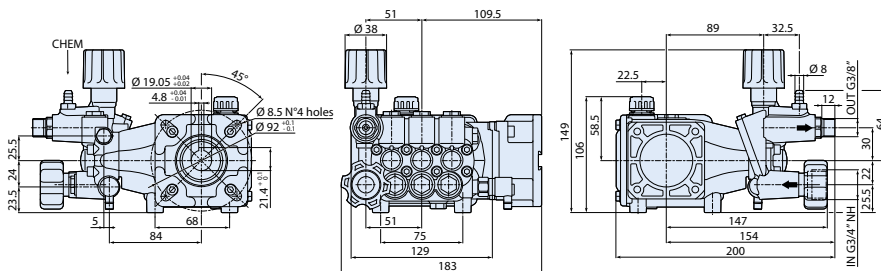

NEW

Model aluminium head

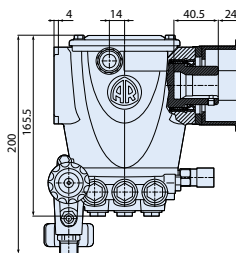

4148507

D version + F7

MOD	COD	MAX	MAX		NET							
		l/min	gpm	bar	psi	hp	kW	N° giri/1'	kg			

JRV 3400rpm Dversion + F7 Ø 3/4"

● JRV 3G20 D TA + F7 **27687** 11,4 3 140 2000 4,2 3 3400 3,5

JRV 3G25 D + F7 **26657** 11,4 3 170 2500 5 3,7 3400 4

Per motori scoppio flangia Ø 3/4" SAE J609a. Flangia inclusa.
For gasoline engine flange Ø 3/4" SAE J609a. Flange included.



testa in
ottone
brass
head



testa in
alluminio
aluminium
head



bielle in
alluminio
aluminium
connecting-rods

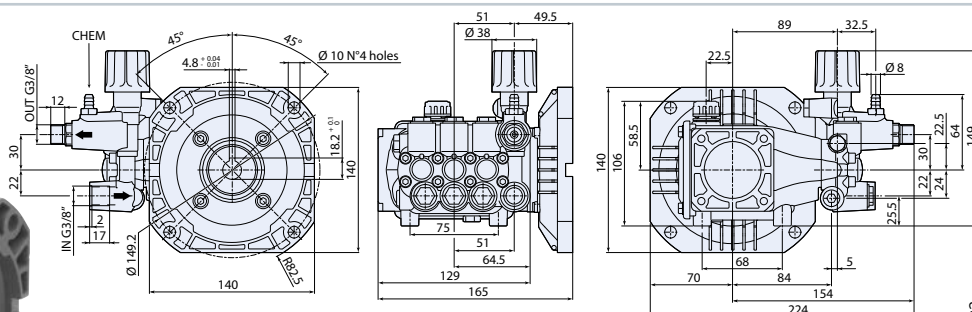
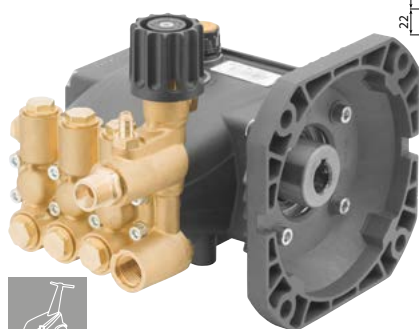

idropultrici
pressure
washers

E version + F8

MOD	COD	MAX	MAX		NET							
		l/min	gpm	bar	psi	hp	kW	N° giri/1'	kg			

JRA 1750rpm Eversion + F8 Ø 5/8"

JRA 2.5G22 E + F8 **26440** 9,5 2,5 150 2200 3,4 2,5 1750 4

JRV 3400rpm Eversion + F8 Ø 5/8"

JRV 2G22 E + F8 **25663** 7,6 2 150 2200 3 2,2 3400 4

Flangia F8 per motori elettrici NEMA 56-C, 60Hz. Flangia inclusa.
F8 flange for electric motor NEMA 56-C, 60Hz. Flange included.



testa in
ottone
brass
head



bielle in
alluminio
aluminium
connecting-rods

4148502



414 Series

POMPA ALBERO MASCHIO Solid shaft pump



misting

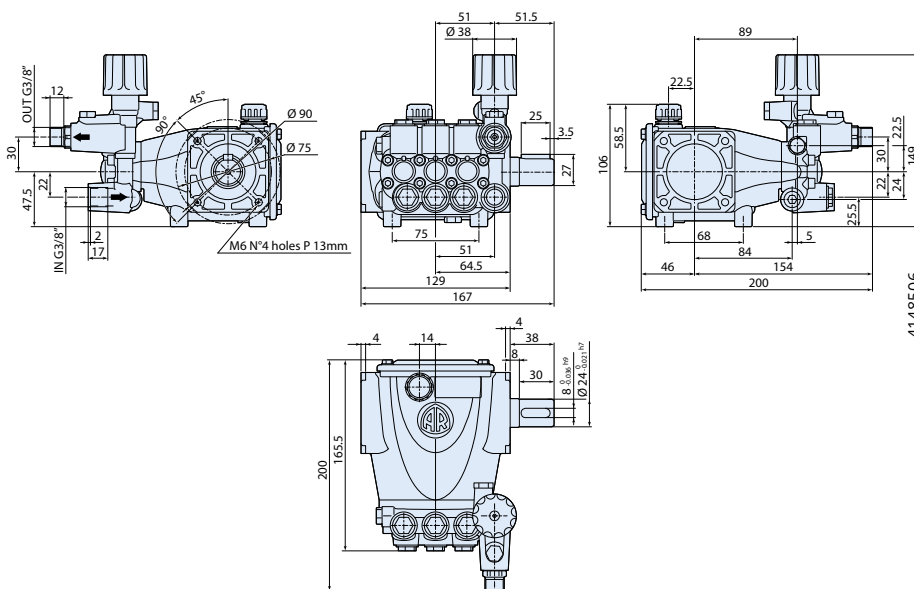

4148506

N version

Flangiatura compatibile XT N.
XT N flange type.

MOD	COD	MAX	MAX		NET				
		l/min	gpm	bar	psi	hp	kW	N° giri/1'	kg
JR-M 1450rpm Nversion Ø24mm									
JR-M 01.10 N	25947	1	0,26	100	1450	0,27	0,2	1450	4
JR-M 02.10 N	25948	2	0,52	100	1450	0,55	0,4	1450	4
JR-M 03.10 N	25949	3	0,8	100	1450	0,8	0,6	1450	4
JRA-M 1750rpm Nversion Ø24mm									
JRA-M 0.25G15 N	25950	1	0,26	100	1450	0,32	0,25	1750	4
JRA-M 0.5G15 N	25951	2	0,52	100	1450	0,65	0,47	1750	4
JRA-M 1G15 N	25952	3,8	1	100	1450	0,92	0,7	1750	4



testa in
ottone
brass
head



bielle in
alluminio
aluminium
connecting-rods



idropultrici
pressure
washers

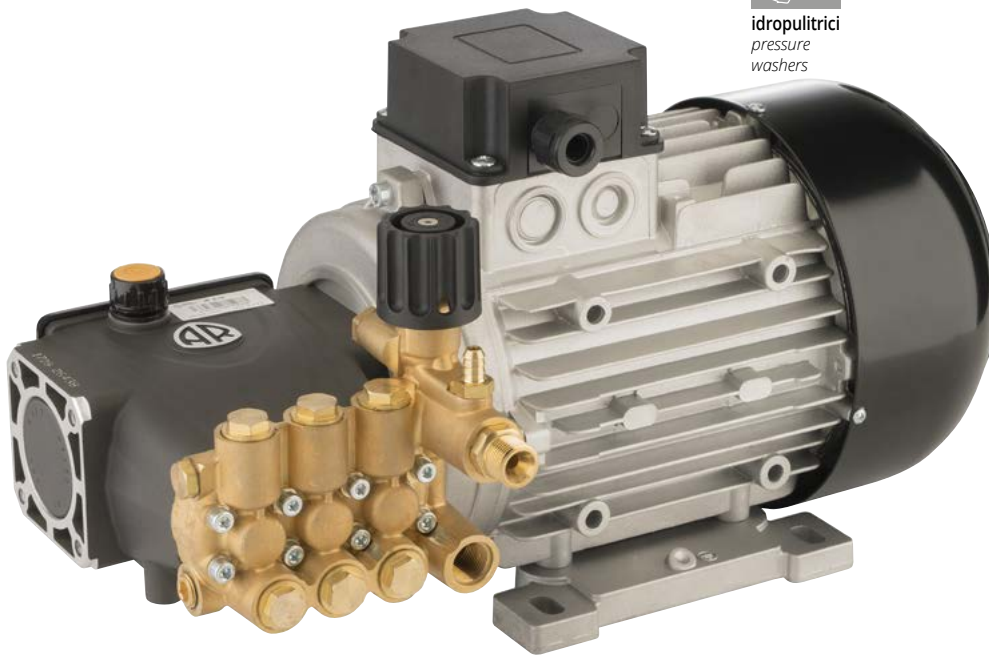

GR. 90 motor hollow shaft

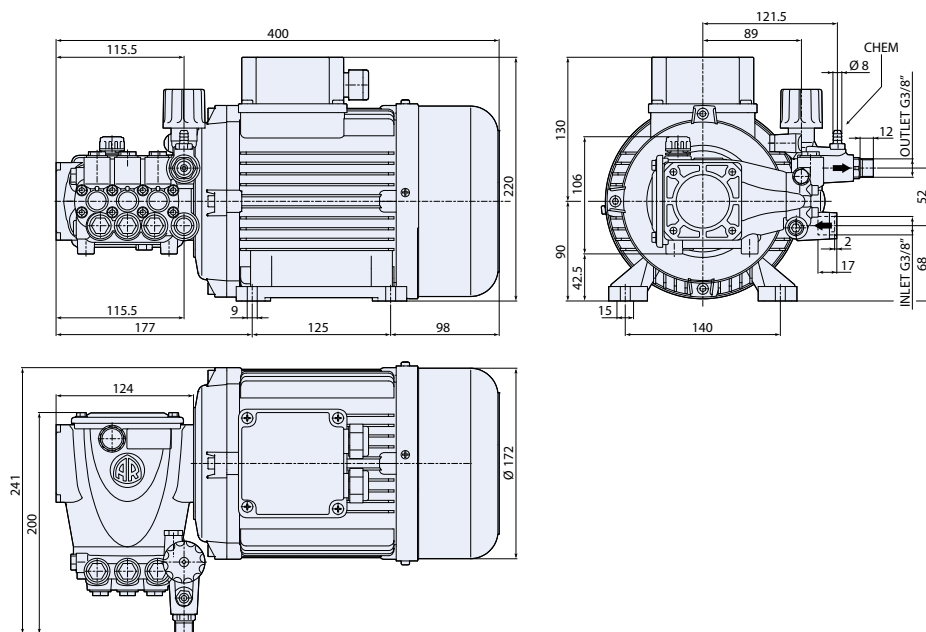

4148509

MOD	COD	MAX		MAX		hp	kW	N° giri/1'	V		Gr.	kg	
		l/min	gpm	bar	psi				1-50Hz	3-50Hz			
HJR 1450rpm													
HJR 8.15 EM	26890	-	8	2,11	150	2200	3	2,2	1450	230	-	90	21,3
HJR 8.15 ET	-	26891	8	2,11	150	2200	3	2,2	1450	-	230/400	90	19
HJRS 2800rpm													
HJRS 8.15 EM	26892	-	8	2,11	150	2200	3	2,2	2800	230	-	90	19
HJRS 10.12 EM	26893	-	10	2,64	120	1740	3	2,2	2800	230	-	90	19
HJRS 10.12 ET	-	26894	10	2,64	120	1740	3	2,2	2800	-	230/400	90	19
HJRS 10.15 ET	-	26895	10	2,64	150	2200	4	3	2800	-	230/400	90	20
HJRS 14.15 ET	-	26896	14	3,7	150	2200	5	3,7	2800	-	230/400	90	21



testa in
ottone
brass
head



bielle in
alluminio
aluminium
connecting-rod



1~50Hz
frequenza
motore
motor
frequency



3~50Hz
frequenza
motore
motor
frequency



414 Series

ELECTRIC MOTOR-PUMP UNITS



idropultrici
pressure
washers



GR. 80 AR motor hollow shaft

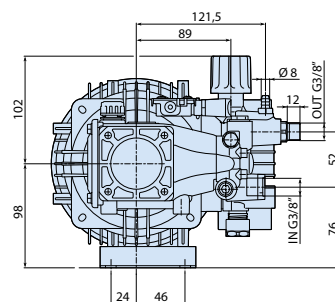
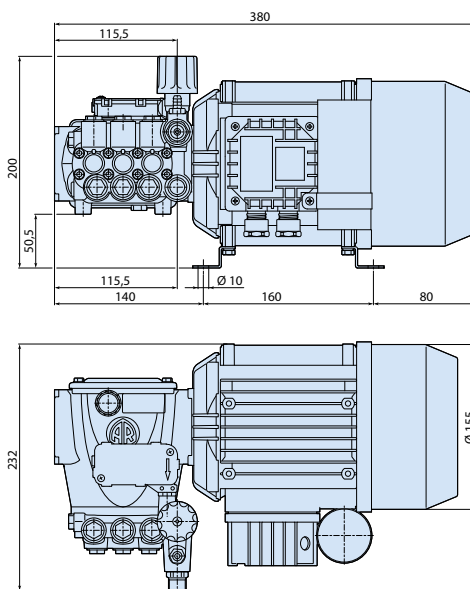

4148512

MOD	COD	MAX	MAX								
	1 ~	l/min	gpm	bar	psi	hp	kW	N° giri/1'	V 1-50Hz	Gr.	kg
HJRS 2800rpm											
HJRS 8.13 TSS EM	27162	8	2,11	130	1900	2,5	2	2800	230	80	19
HJRS 8.15 TSS EM	27163	8	2,11	150	2200	3	2,2	2800	230	80	17,8
HJRS 10.12 TSS EM	27164	10	2,64	120	1740	3	2,2	2800	230	80	19



testa in
ottone
brass
head



bielle in
alluminio
aluminium
connecting-rods



1-50Hz
frequenza
motore
motor
frequency



TSS®
Total Stop
SYSTEM



misting



GR. 80 AR motor hollow shaft

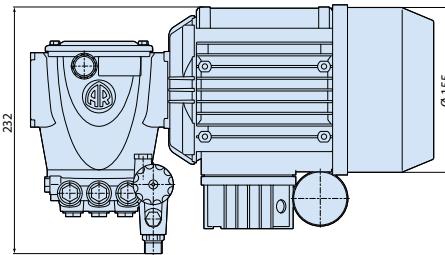
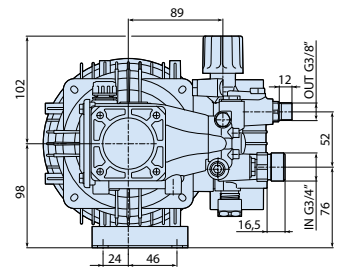
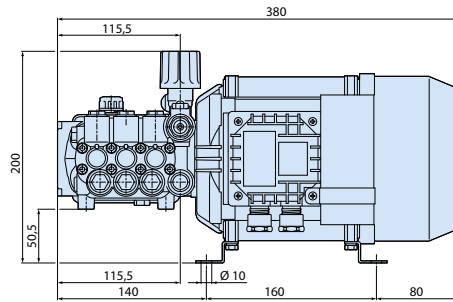

4148511

MOD	COD	MAX		MAX						KG	NET
	1 ~	l/min	gpm	bar	psi	hp	kW	N° giri/1'	V 1-50Hz	Gr.	kg
HJR-M 1450rpm											
HJR-M 01.10 EM	27159	1	0,26	100	1450	0,5	0,35	1450	230	80	16
HJR-M 02.10 EM	27160	2	0,52	100	1450	0,5	0,35	1450	230	80	16
HJR-M 03.10 EM	27161	3	0,8	100	1450	0,8	0,6	1450	230	80	16



testa in ottone
brass head



bielle in alluminio
aluminium connecting-rods



1~50Hz
frequenza motore
motor frequency



RC
RCA
RCS
RCV
RC-M
RCA-M
HRC

320 SERIES



320 SERIES

RC
RCA
RCS
RCV
RC-M
RCA-M

HRC



Corpo e coperchi in alluminio pressofuso.

Coperchio laterale chiuso o con livello olio. Coperchio posteriore con scarico olio.

Bielle in lega zinco- alluminio pressofuso.

Testa in ottone stampato con possibilità di valvola di regolazione integrata.

Pistoni in ceramica.

Crankcase and back cover in pressure die-cast aluminium alloy.

Side cover closed or incorporated with oil sight glass. Back cover incorporated with oil drain outlet.

Connecting rods in die-cast zinc-aluminium alloy.

Pump head in forged brass. Possibility to have integrated pressure regulating valve on pump head.

Ceramic plungers.



idropultrici
pressure
washers

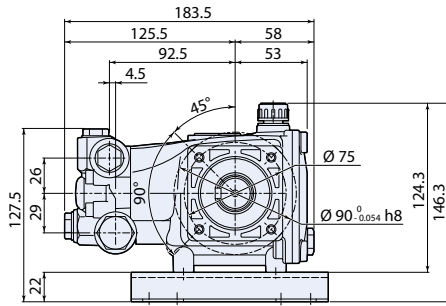

Piedi a richiesta.
Base on request.

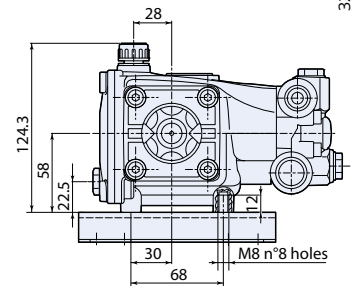
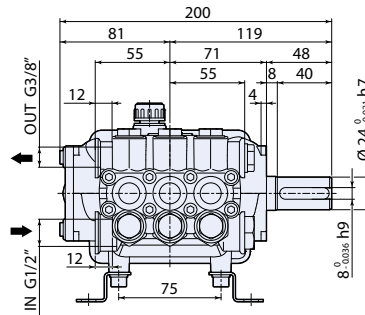

3208500



NEW

Disponibile versione testa
in inox su richiesta.
Stainless-steel head version
available on request.

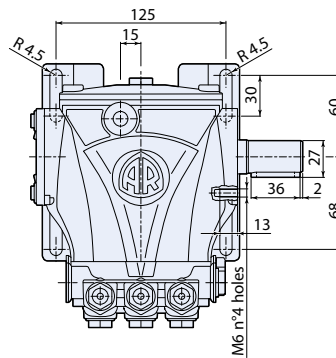

Flangiatura compatibile XT N.
XT N flange type.

N version

MOD	COD	MAX	MAX						
		l/min	gpm	bar	psi	hp	kW	N° giri/1'	kg

RC 1450rpm Nversion Ø24mm									
RC 8.15 N	23260	8	2,11	150	2200	3	2,2	1450	5
RC 9.15 N	23263	9	2,37	150	2200	3,5	3	1450	5
RC 10.12 N	23384	10	2,64	120	1740	3	2,2	1450	5
RC 10.15 N	23436	10	2,64	150	2200	4	3	1450	5
RC 11.17 N	23261	11	2,90	170	2500	5	3,7	1450	5
RC 12.17 N	23262	12	3,20	170	2500	5,5	4	1450	5
RC 13.17 N	23081	13	3,43	170	2500	5,5	4	1450	5
RC 14.16 N	23301	14	3,70	160	2300	5,5	4	1450	5
RC 14.20 N	26920	14	3,70	200	2900	7,5	5,5	1450	5
RCA 1750rpm Nversion Ø24mm									
RCA 2.5G25 N	23437	9,5	2,5	170	2500	4,5	3,3	1750	5
RCA 3G25 N	23438	11,4	3	170	2500	5	3,7	1750	5
RCA 3.5G25 N	23264	13,2	3,5	170	2500	5,5	4	1750	5
RCS 2800rpm Nversion Ø24mm									
RCS 8.17 N	23667	8	2,11	170	2500	3	2,2	2800	5
RCS 11.17 N	23670	11	2,90	170	2500	5	3,7	2800	5
RCS 13.17 N	23671	13	3,43	170	2500	5,5	4	2800	5
RCS 15.15 N	23672	15	3,96	150	2200	5,5	4	2800	5



testa in
ottone
brass
head



bielle in
alluminio
aluminium
connecting-rod



320 series

POMPA ALBERO CAVO Hollow shaft pump



idropultrici
pressure
washers

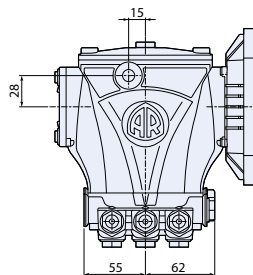
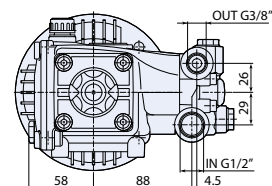
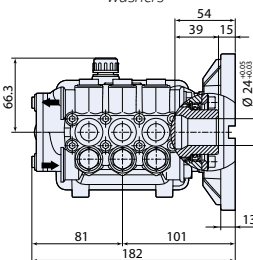
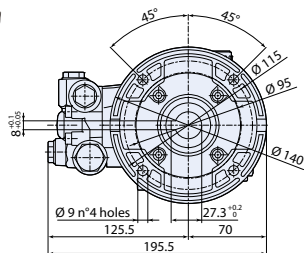

3208503

C version + F6

MOD	COD	MAX	MAX		NET				
		l/min	gpm	bar	psi	hp	kW	N° giri/1'	kg



testa in
ottone
brass
head



bielle in
alluminio
aluminium
connecting-rods

RC 1450rpm Cversion + F6 Ø24mm

RC 8.15 C + F6	23493	8	2,11	150	2200	3	2,2	1450	5,5
RC 9.14 C + F6	23494	9	2,37	140	2000	3,3	2,4	1450	5,5
RC 11.11 C + F6	23495	11	2,90	110	1600	3	2,2	1450	5,5

Flangia F6, per motori elettrici B14 Gr.90 IEC34-7, 4 poli 50Hz. Flangia inclusa.
F6 flange for electric motor B14 90 IEC34-7, 4 poles 50Hz. Flange included.

POMPA ALBERO CAVO Hollow shaft pump

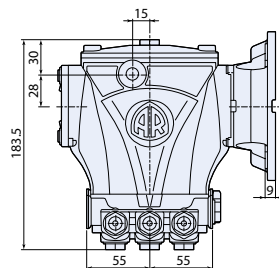
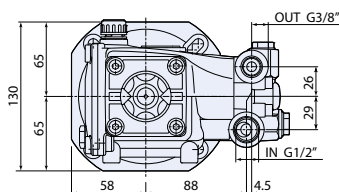
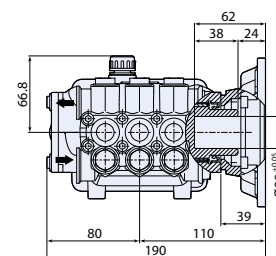
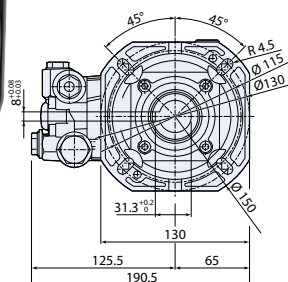

3208509



idropultrici
pressure
washers

C version + F44

MOD	COD	MAX	MAX		NET				
		l/min	gpm	bar	psi	hp	kW	N° giri/1'	kg



testa in
ottone
brass
head



bielle in
alluminio
aluminium
connecting-rods

RC 1450rpm Cversion + F44 Ø28mm

RC 12.10 C + F44	23902	12	3,20	100	1450	3	2,2	1450	5,5
RC 13.17 C + F44	23535	13	3,43	170	2500	5,5	4	1450	5,5
RC 14.16 C + F44	23536	14	3,70	160	2300	5,5	4	1450	5,5

Flangia F44 per motori elettrici B14 Gr.100 IEC34-7, 4 poli 50Hz. Flangia inclusa.
F44 flange for electric motor B14 100 IEC34-7, 4 poles 50Hz. Flange included.



idropultrici
pressure
washers

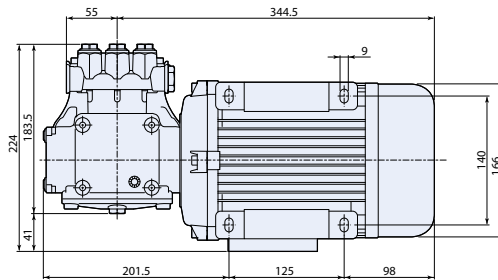
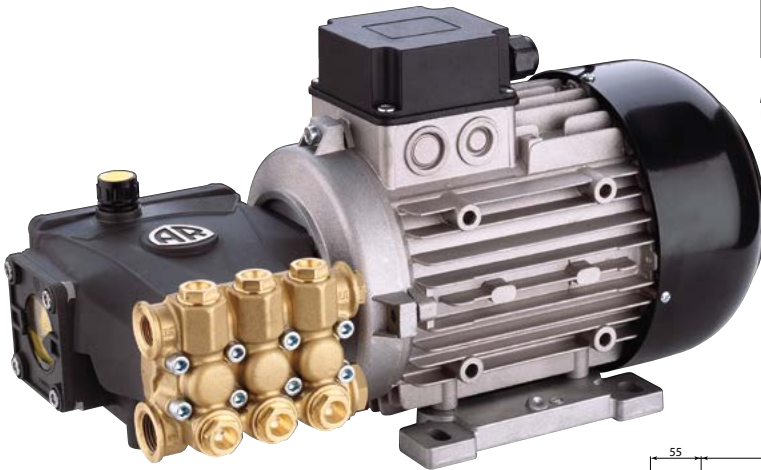

GR. 90L motor hollow shaft
1~

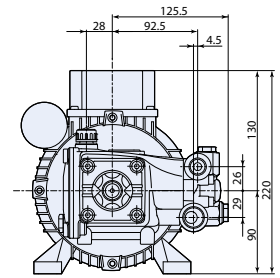
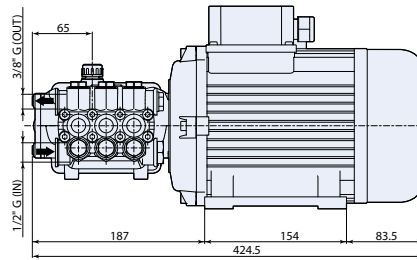

3208525

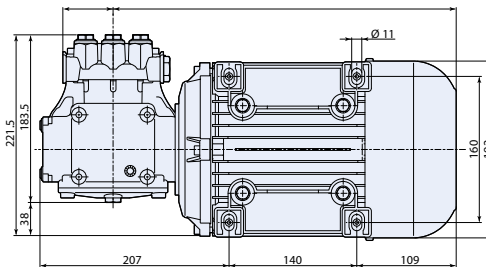

GR. 100 motor hollow shaft
3~

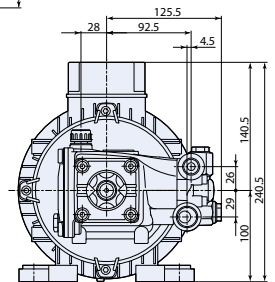
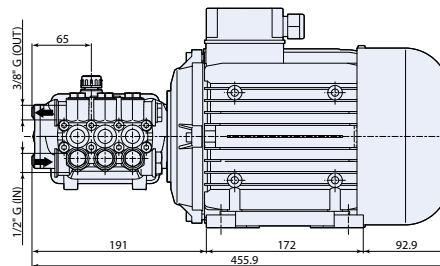

3208510

MOD	COD												
	1~	3~	l/min	gpm	bar	psi	hp	kW	N° giri/1'	V 1-50Hz	V 3-50Hz	Gr.	kg



testa in
ottone
brass
head



bielle in
alluminio
aluminium
connecting-rod

HRC 1450rpm													
HRC 10.13 EM	23485	-	10	2,64	130	1900	3	2,2	1450	230	-	90	22,1
HRC 12.11 EM	23486	-	12	3,20	110	1600	3	2,2	1450	230	-	90	22,3
HRC 11.15 ET	-	23453	11	2,90	150	2200	4	3	1450	-	230/400	100	28
HRC 13.17 ET	-	23454	13	3,43	170	2500	5,5	4	1450	-	230/400	100	30
HRC 14.16 ET	-	23455	14	3,70	160	2300	5,5	4	1450	-	230/400	100	30



1~50Hz
frequenza
motore
motor
frequency



3~50Hz
frequenza
motore
motor
frequency

132 SERIES

XT
XTS
XTA
XTV
HXT



Corpo e coperchi in alluminio pressofuso.

Coperchio posteriore con livello olio.

Bielle in lega zinco- alluminio pressofuso oppure in bronzo.

Testa in ottone stampato o in lega d'alluminio pressofuso.

Pistoni in ceramica.

Crankcase and back cover in pressure die-cast aluminium alloy.

Back cover incorporated with oil sight glass.

Connecting rods in die-cast zinc-aluminium alloy. Bronze connecting rods available.

Pump head in forged brass or die-cast aluminium alloy.

Ceramic plungers.



idropultrici
pressure
washers

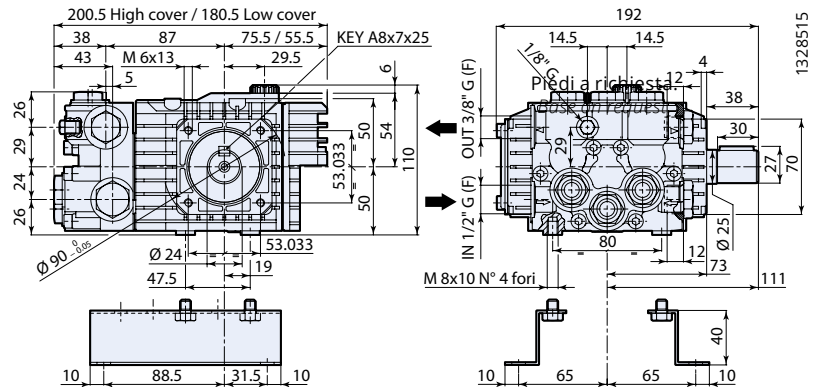

N version

MOD	COD	MAX		MAX				N° giri/1'	KG NET
		l/min	gpm	bar	psi	hp	kW		
XT 1450rpm Nversion Ø24mm									
XT 8.15 N	6979	8	2,11	150	2200	3	2,2	1450	5
XT 9.15 N	6980	9	2,37	150	2200	3,5	3,2	1450	5
XT 10.15 N	6978	10	2,64	150	2200	4	3	1450	5
XT 11.15 N	6981	11	2,90	150	2200	4,3	3,2	1450	5
XT 13.15 N	6982	13	3,43	150	2200	5	3,6	1450	5
XTS 2800rpm Nversion Ø24mm									
XTS 8.15 N	7412	8	2,11	150	2200	3	2,2	2800	5
XTS 10.15 N	7413	10	2,64	150	2200	4	3	2800	5
XTS 11.15 N	7414	11	2,90	150	2200	4,3	3,2	2800	5
XTS 13.15 N	7415	13	3,43	150	2200	5	3,6	2800	5
XTA 1750rpm Nversion Ø24mm									
XTA 2G22 N	7416	8	2,11	150	2200	3	2,2	1750	5
XTA 3G22 N	7417	11,4	3	150	2200	4,5	3,4	1750	5
XTA 3.5G20 N	7418	13,2	3,5	140	2000	5	3,6	1750	5



testa in
ottone
brass
head



bielle in
bronzo
bronze
connecting-rods



132 Series

POMPA ALBERO CAVO Hollow shaft pump



idropultrici
pressure
washers



1328507

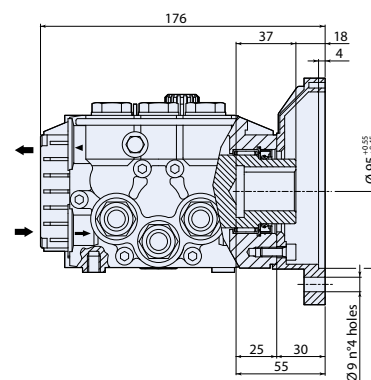
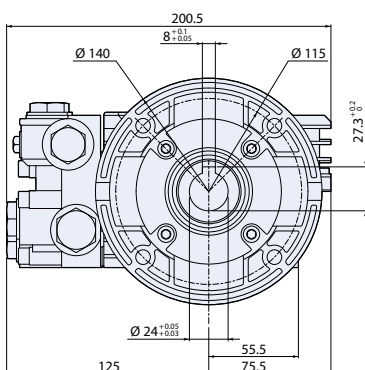

Flangia F6 fornita a richiesta.
F6 flange on request.

C version

MOD	COD	MAX		MAX		hp	kW	N° giri/1'	kg	
		l/min	gpm	bar	psi					
XT 1450rpm Cversion Ø24mm										
XT 8.14 C	7025	8	2,11	140	2000	3	2,2	1450	5	
XT 9.14 C	6991	9	2,37	140	2000	3,3	2,4	1450	5	
XT 11.14 C	7104	11	2,90	140	2000	4	3	1450	4	
XTS 2800rpm Cversion Ø24mm										
XTS 8.14 C	7068	8	2,11	140	2000	3	2,2	2800	5	
XTS 11.14 C	7069	11	2,90	140	2000	4	3	2800	5	
XTS 13.12 C	7287	13	3,43	120	1740	4	3	2800	5	

Flangia F6, per motori elettrici B14 Gr.90 IEC34-7. Flangia non inclusa.
F6 flange for electric motor B14-90 IEC34-7. Flange not included.



testa in
ottone
brass
head



bielle in
bronzo
bronze
connecting-rods



bielle in
alluminio
aluminium
connecting-rods

132 Series

POMPA ALBERO CAVO Hollow shaft pump





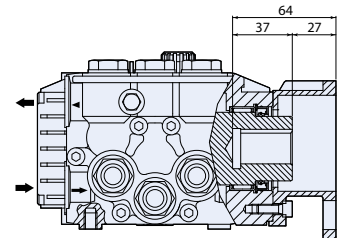
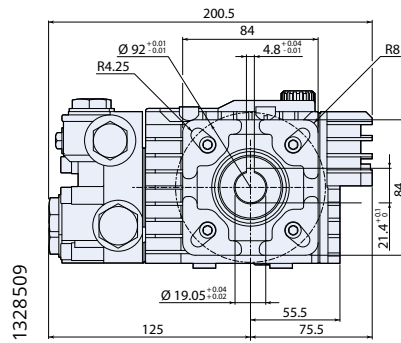

idropulitrici
pressure
washers



Flangia F7 fornita a richiesta.
F7 flange on request.

D version

MOD	COD	 MAX	 MAX						
		l/min	gpm	bar	psi	hp	kW	N° giri/1'	kg
XTV 3400 rpm Dversion Ø3/4"									
XTV 2G22 D	7419	8	2,11	150	2200	3	2,2	3400	5
XTV 3G22 D	7420	11,4	3	150	2200	4,5	3,4	3400	5



testa in
ottone
brass
head



bielle in
bronzo
bronze
connecting-rods

Per motori scoppio flangia F7 Ø 3/4" SAE J609a. Flangia non inclusa.
For gasoline engine flange F7 Ø 3/4" SAE J609a. Flange not included.



132 Series

ELECTRIC MOTOR-PUMP UNITS



idropultrici
pressure
washers

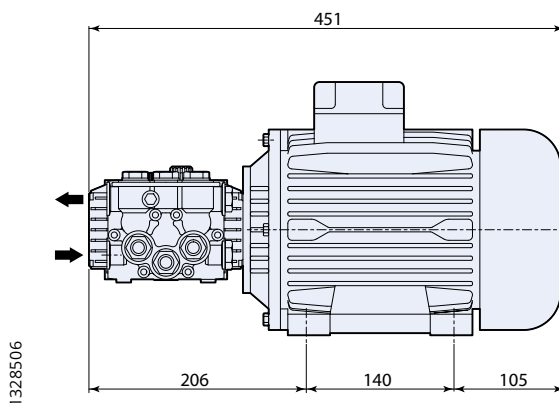

GR. 100 motor hollow shaft

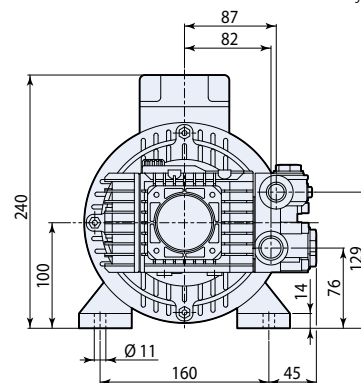

MOD	COD		MAX		MAX		hp	kW	N° giri/1'	V		Gr.	kg
	1 ~	3 ~	l/min	gpm	bar	psi				1-50Hz	3-50Hz		
HXT 1450 rpm													
HXT 8.14 EM	7146	-	8	2,11	140	2000	3	2,2	1450	230	-	100	28,5
HXT 11.14 ET	-	7154	11	2,90	140	2000	4	3	1450	-	230/400	100	30
HXT 13.12 ET	-	7155	13	3,43	120	1740	4	3	1450	-	230/400	100	30



testa in
ottone
brass
head



bielle in
bronzo
bronze
connecting-rods



1~50Hz
frequenza
motore
motor
frequency



3~50Hz
frequenza
motore
motor
frequency



idropultrici
pressure
washers



*XTV 3400 rpm Direct Drive
from Honda engine*

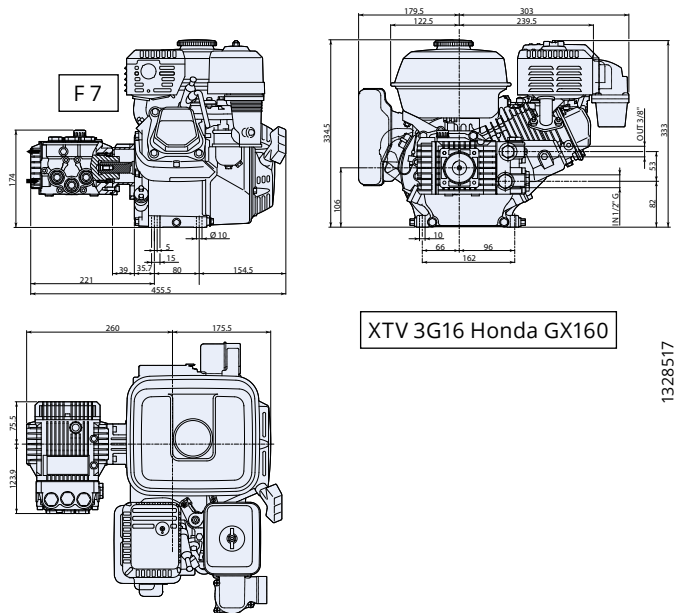

XTV 3G16 Honda GX160

1328517

MOD	COD	MAX	MAX	RPM	NET			
		l/min	gpm	bar	psi	N° giri/1'	kg	
XTV Direct Drive								
XTV 3G16 HONDA GX 160K1-QX Type	4,8	7469	11,4	3	110	1600	3400	20



testa in
ottone
brass
head



bielle in
alluminio
aluminium
connecting-rods



motore a
scoppio
gasoline
engine

178 SERIES

XM · SXM
XMA · SXMA
XMS · SXMS
XMV · SXMV
XM-M
XHW

HXM · HSXM
XM+F38
HYD-XM



Corpo e coperchi in alluminio pressofuso.

Coperchio posteriore con livello olio e scarico olio.

Bielle in lega zinco-alluminio pressofuso oppure in bronzo.

Testa in ottone stampato.

Pistoni in ceramica.

Possibilità di avere il corpo con trattamento di cataforesi (versione hot water).

Guarnizioni in PTFE (versione hot water).

Crankcase and back cover in pressure die-cast aluminium alloy.

Back cover incorporated with oil sight glass and oil drain outlet.

*Connecting rods in die-cast zinc-aluminium alloy.
Bronze connecting rods available.*

Pump head in forged brass.

Ceramic plungers.

Crankcase with cathaphoresis treatment (hot water version).

PTFE gasket sealing (hot water version).



idropulitrici
pressure
washers

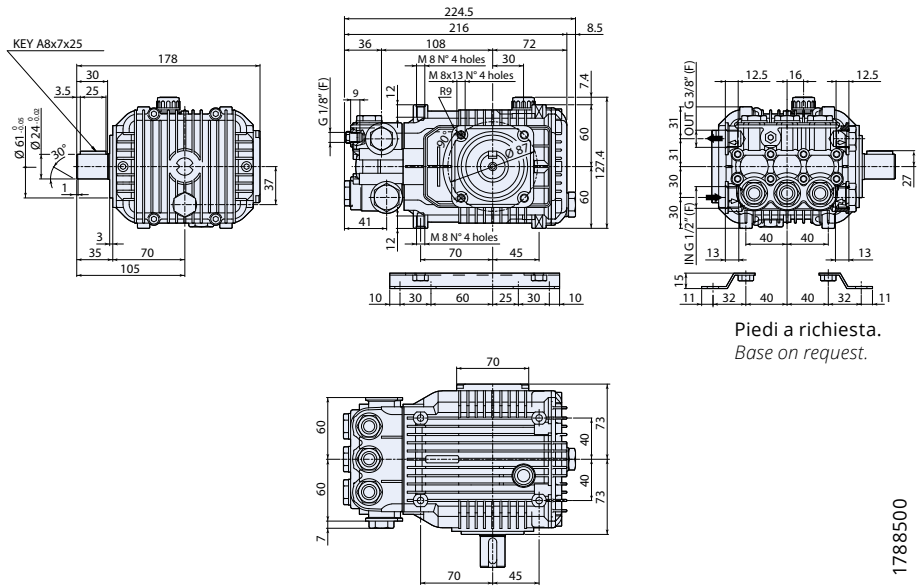

Piedi a richiesta.
Base on request.

1788500

N version

MOD	COD	MAX	MAX						
		l/min	gpm	bar	psi	hp	kW	N° giri/1'	kg
XM 1450rpm Nversion Ø24mm									
XM 11.17 N	7900	11	2,90	170	2500	5	3,7	1450	6,5
XM 13.17 N	7902	13	3,43	170	2500	5,5	4	1450	6,5
XM 15.15 N	7906	15	3,96	150	2200	5,5	4	1450	6,5
SXM 1450rpm Nversion Ø24mm									
SXM 11.20 N	21374	11	2,90	200	2900	5,5	4	1450	6,5
SXM 13.20 N	21267	13	3,43	200	2900	7,5	5,5	1450	6,5
SXM 15.20 N	21265	15	3,96	200	2900	7,5	5,5	1450	6,5
XMS 2800rpm Nversion Ø24mm									
XMS 11.17 N	7908	11	2,90	170	2500	5	3,7	2800	6,5
XMS 13.17 N	7910	13	3,43	170	2500	5,5	4	2800	6,5
XMS 15.15 N	7912	15	3,96	150	2200	5,5	4	2800	6,5
XMS 15.20 N	20511	15	3,96	200	2900	7,5	5,5	2800	6,5
SXMS 2800rpm Nversion Ø24mm									
SXMS 11.20 N	21376	11	2,90	200	2900	5,5	4,1	2800	6,5
SXMS 13.20 N	21257	13	3,43	200	2900	7,5	5,5	2800	6,5
SXMS 15.20 N	21258	15	3,96	200	2900	7,5	5,5	2800	6,5



testa in
ottone
brass
head



bielle in
bronzo
bronze
connecting-rods



bielle in
alluminio
aluminium
connecting-rods



178 Series

POMPA ALBERO MASCHIO Solid shaft pump



idropulitrici
pressure
washers

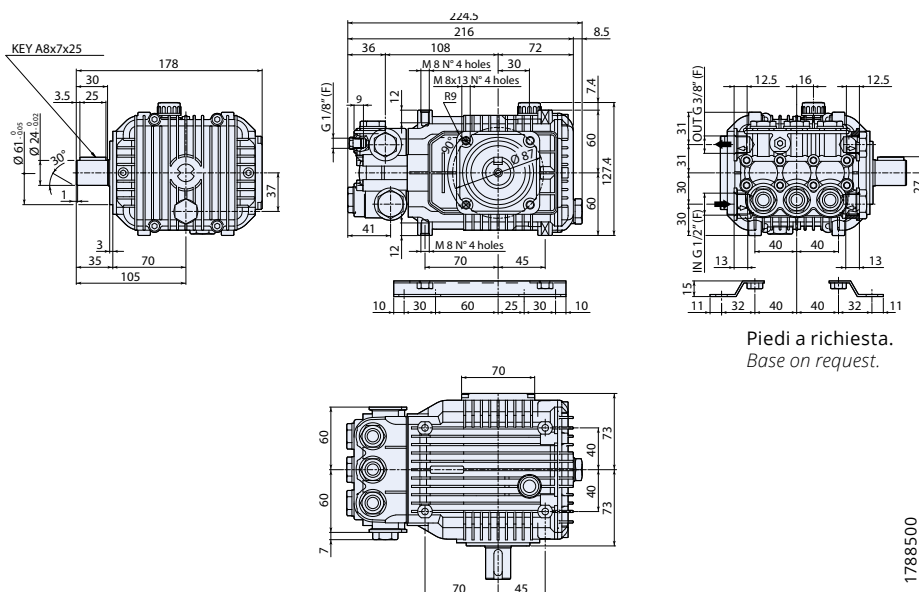

Piedi a richiesta.
Base on request.

1788500

N version

MOD	COD	MAX	MAX						
		l/min	gpm	bar	psi	hp	kW	N° giri/1'	kg
XMA 1750rpm Nversion Ø24mm									
XMA 3G25 N	7916	11,4	3	170	2500	5	3,7	1750	6,5
XMA 3.5G22 N	7918	13,2	3,5	150	2200	5	3,7	1750	6,5
XMA 3.5G25 N	7920	13,2	3,5	170	2500	5,5	4	1750	6,5
XMA 4G20 N	7922	15,1	4	140	2000	5,5	4	1750	6,5
SXMA 1750rpm Nversion Ø24mm									
SXMA 3G30 N	21401	11,4	3	205	3000	5,5	4	1750	6,5
SXMA 3.5G30 N	21406	13,2	3,5	205	3000	7	5,2	1750	6,5
SXMA 4G30 N	21261	15,1	4	205	3000	7,5	5,5	1750	6,5
XMV 3400rpm Nversion Ø24mm									
XMV 3G30 N	20529	11,4	3	205	3000	5,5	4	3400	6,5
XMV 3.5G25 N	7928	13,2	3,5	170	2500	5,5	4	3400	6,5
XMV 4G22 N	7932	15,1	4	150	2200	5,5	4	3400	6,5
XMV 4G30 N	20849	15,1	4	205	3000	7,5	5,5	3400	6,5
SXMV 3400rpm Nversion Ø24mm									
SXMV 3G35 N	21379	11,4	3	240	3500	7,5	5,5	3400	6,5
SXMV 3.5G35 N	21380	13,2	3,5	240	3500	10	7,5	3400	6,5
SXMV 4G35 N	21263	15,1	4	240	3500	10	7,5	3400	6,5



testa in
ottone
brass
head



bielle in
bronzo
bronze
connecting-rods



bielle in
alluminio
aluminium
connecting-rods



idropulitrici
pressure
washers

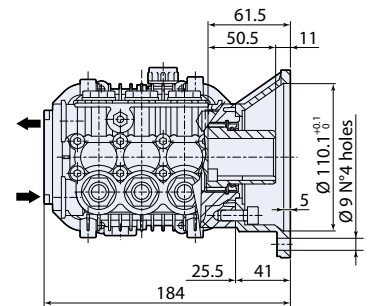
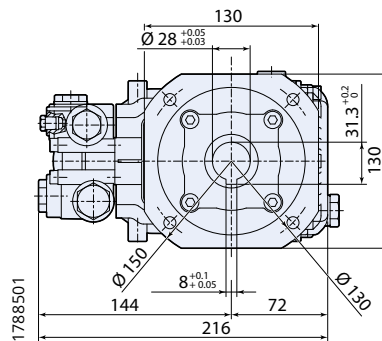

Flangia F16 fornita a richiesta.
F16 flange on request.

C version

MOD	COD	MAX		MAX		MAX		N° giri/1'	kg
		l/min	gpm	bar	psi	hp	kW		
XM 1450rpm Cversion Ø28mm									
XM 11.17 C	7936	11	2,90	170	2500	5	3,7	1450	6,5
XM 13.17 C	7938	13	3,43	170	2500	5,5	4	1450	6,5
XM 15.15 C	7942	15	3,96	150	2200	5,5	4	1450	6,5
SXM 1450rpm Cversion Ø28mm									
SXM 11.20 C	21375	11	2,90	200	2900	5,5	4	1450	6,5
SXM 13.20 C	21255	13	3,43	200	2900	7,5	5,5	1450	6,5
SXM 15.20 C	21256	15	3,96	200	2900	7,5	5,5	1450	6,5
XMS 2800rpm Cversion Ø28mm									
XMS 11.17 C	7944	11	2,90	170	2500	5	3,7	2800	6,5
XMS 13.17 C	7946	13	3,43	170	2500	5,5	4	2800	6,5
XMS 15.15 C	7948	15	3,96	150	2200	5,5	4	2800	6,5
SXMS 2800rpm Cversion Ø28mm									
SXMS 11.20 C	21377	11	2,90	200	2900	5,5	4	2800	6,5
SXMS 13.20 C	21259	13	3,43	200	2900	7,5	5,5	2800	6,5
SXMS 15.20 C	21260	15	3,96	200	2900	7,5	5,5	2800	6,5



Flangia F16 per motori elettrici B14 Gr.100÷112 IEC34-7, 50Hz. Flangia non inclusa.
F16 flange for electric motor B14 100÷112 IEC34-7, 50Hz. Flange not included.



178 Series

POMPA ALBERO CAVO Hollow shaft pump



idropultrici
pressure
washers

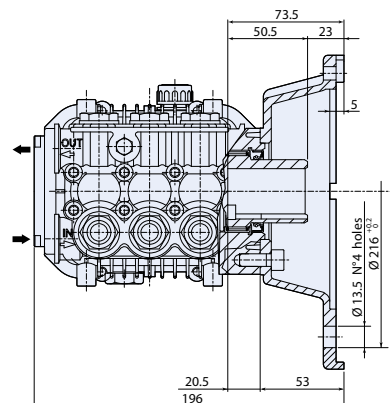
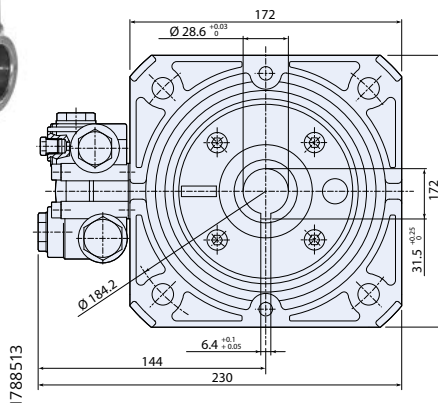

Flangia F17 fornita a richiesta.
F17 flange on request.

E version

MOD	COD	MAX	MAX		NET				
		l/min	gpm	bar	psi	hp	kW	N° giri/1'	kg
XMA 1750 rpm Eversion Ø 1" 1/8									
XMA 3G25 E	7952	11,4	3	170	2500	5	3,7	1750	6,5
XMA 3.5G25 E	7956	13,2	3,5	170	2500	5,5	4	1750	6,5
XMA 4G20 E	7958	15,1	4	140	2000	5,5	4	1750	6,5



testa in
ottone
brass
head



bielle in
alluminio
aluminium
connecting-rods

Flangia F17 per motori elettrici NEMA 182-184, 4 poli 60Hz. Flangia non inclusa.
F17 flange for electric motor NEMA 182-184, 4 poles 60Hz. Flange not included.

POMPA ALBERO CAVO Hollow shaft pump



idropultrici
pressure
washers

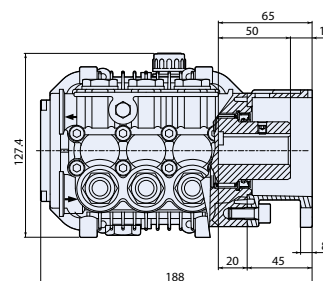
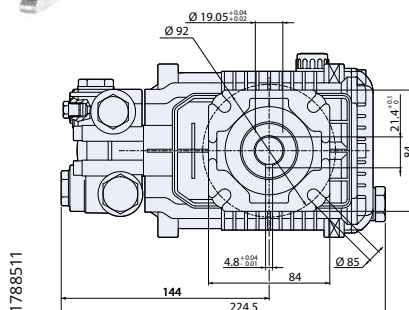

D version + F25

MOD	COD	MAX	MAX		NET				
		l/min	gpm	bar	psi	hp	kW	N° giri/1'	kg
XMV 3400 rpm Eversion + F25 Ø 3/4"									
XMV 3G30 D + F25	20095	11,4	3	205	3000	5,5	4	3400	7
XMV 3.5G25 D + F25	7996	13,2	3,5	170	2500	5,5	4	3400	7



testa in
ottone
brass
head



bielle in
alluminio
aluminium
connecting-rods

Flangia F25 per motori scoppio Ø 3/4" SAE J609a. Flangia inclusa.
F25 flange for gasoline engine Ø 3/4" SAE J609a. Flange included.



idropultrici
pressure
washers

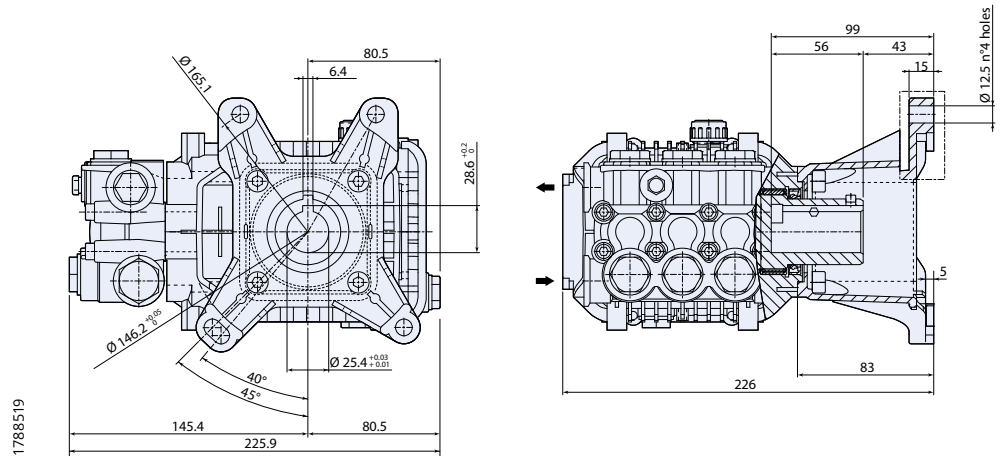

D version + F40

MOD	COD	MAX		MAX				N°		KG NET
		l/min	gpm	bar	psi	hp	kW	giri/1'	kg	
XMV 3400rpm Dversion + F40 Ø1"										
XMV 3G30 D + F40	20111	11,4	3	205	3000	5,5	4	3400	7	
XMV 3.5G30 D + F40	21128	13,2	3,5	205	3000	7	5,2	3400	7	
XMV 4G25 D + F40	7990	15,1	4	170	2500	7	5,2	3400	7	
XMV 4G30 D + F40	20820	15,1	4	205	3000	7,5	5,5	3400	7	
SXMV 3400rpm Dversion + F40 Ø1"										
SXMV 3G35 D + F40	21381	11,4	3	240	3500	7,5	5,5	3400	7	
SXMV 3.5G35 D + F40	21382	13,2	3,5	240	3500	8,5	6,2	3400	7	
SXMV 4G35 D + F40	21264	15,1	4	240	3500	10	7,5	3400	7	

Flangia F40 per motori scoppio Ø 1" SAE J609a. Flangia inclusa.
F40 flange for gasoline engine Ø 1" SAE J609a. Flange included.



testa in
ottone
brass
head



bielle in
bronzo
bronze
connecting-rods



bielle in
alluminio
aluminium
connecting-rods



178 Series

POMPA ALBERO MASCHIO Solid shaft pump



misting

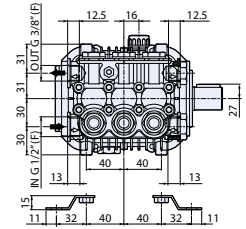
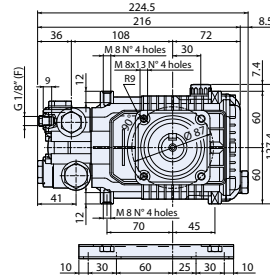
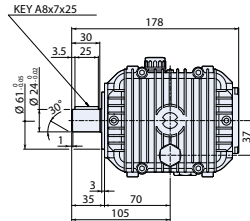

Piedi a richiesta.
Base on request.

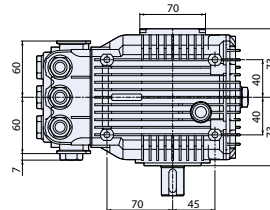

N version

MOD	COD	MAX	MAX						
		l/min	gpm	bar	psi	hp	kW	N° giri/1'	kg
XM-M 1450rpm Nversion Ø24mm									
XM-M 01.10 N	22092	1	0,26	100	1450	0,3	0,2	1450	6,5
XM-M 02.10 N	22093	2	0,52	100	1450	0,5	0,4	1450	6,5
XM-M 04.10 N	22094	4	1,06	100	1450	1	0,8	1450	6,5
XM-M 08.10 N	22095	8	2,11	100	1450	2	1,5	1450	6,5



testa in ottone
brass head



bielle in alluminio
aluminium connecting-rods

1788500

POMPA ALBERO MASCHIO Solid shaft pump

HOT WATER 85°C

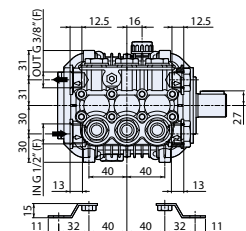
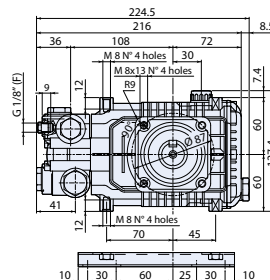
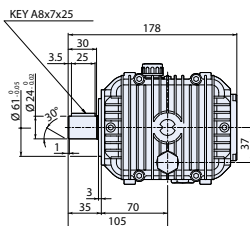

Piedi a richiesta.
Base on request.

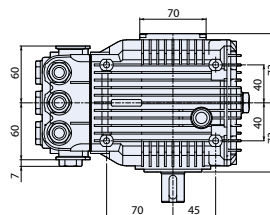

autolavaggio municipality
car wash

N version

MOD	COD	MAX	MAX						
		l/min	gpm	bar	psi	hp	kW	N° giri/1'	kg
XHW 1450rpm Nversion Ø24mm									
XHW 08.15 N	23972	8	2,11	150	2200	3	2,2	1450	6,5
XHW 11.17 N	22543	11	2,90	170	2500	5	3,7	1450	6,5



testa nichelata
nickel plated
brass head



guarnizioni in PTFE
PTFE gasket
sealing



MAX
85°



bielle in bronzo
bronze
connecting-rods

1788500



idropultrici
pressure
washers



GR. 112 motor hollow shaft

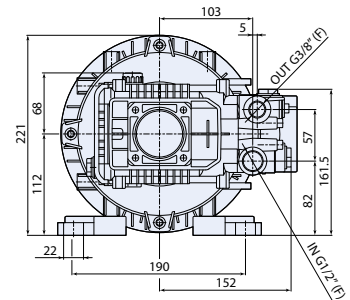
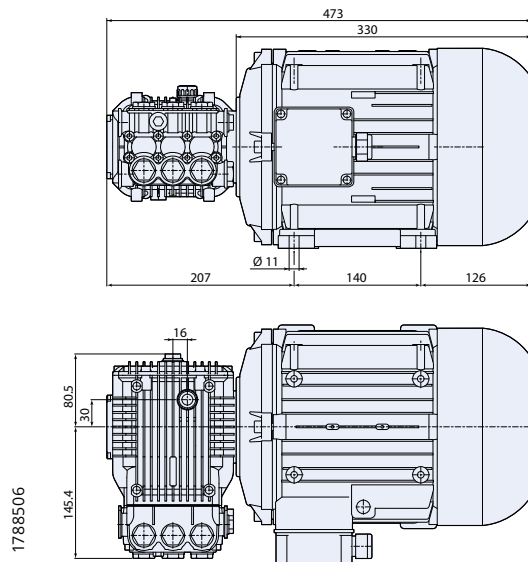

MOD	COD	MAX		MAX						KG	
	3 ~	l/min	gpm	bar	psi	hp	kW	N° giri/1'	V 3-50Hz	Gr.	kg
HXM - HSXM 1450rpm											
HXM 13.17 ET	20196	13	3,43	170	2500	5,5	4	1450	230/400	112	30
HSXM 13.20 ET	21370	13	3,43	200	2900	7,5	5,5	1450	230/400	112	38
HXM 15.15 ET	20197	15	3,96	150	2200	5,5	4	1450	230/400	112	30
HSXM 15.20 ET	21371	15	3,96	200	2900	7,5	5,5	1450	230/400	112	37,7



testa in
ottone
brass
head



bielle in
bronzo
bronze
connecting-rods



bielle in
alluminio
aluminium
connecting-rods



frequenza
motore
motor
frequency



178 Series

GASOLINE MOTOR-PUMP UNITS



idropultrici
pressure
washers

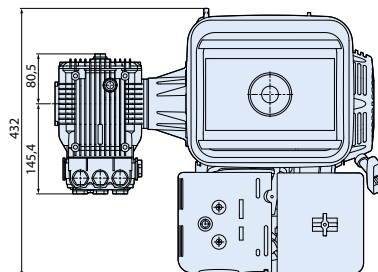
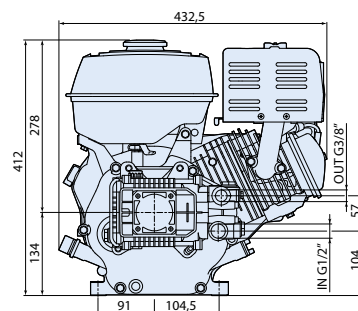
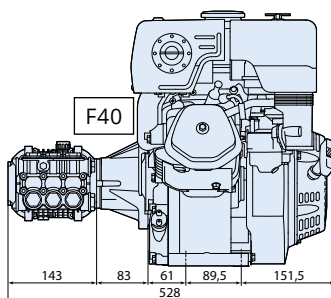

1788538

MOD	COD	MAX	MAX	RPM	NET			
		l/min	gpm	bar	psi	N° giri/1'	kg	
XMV Direct Drive								
XMV 4G20 HONDA GX 270-QX Type	8,4	20237	15,1	4	140	2000	3400	32



testa in
ottone
brass
head



bielle in
alluminio
aluminium
connecting-rods



motore a
scoppio
gasoline
engine

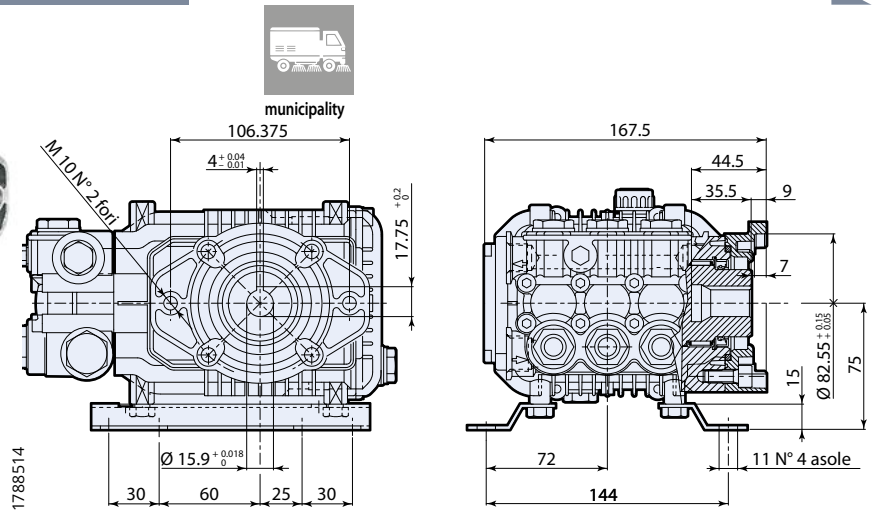

Piedi a richiesta.
Base on request.

XM + F38

MOD	COD	MAX	MAX		NET				
		l/min	gpm	bar	psi	hp	kW	N° giri/1'	kg

XM 1450rpm + F 38									
XM 15.15 + F38	21598	15	3,96	150	2200	5,5	4	1450	6,7

Flangia F38 per motori idraulici SAE A82.55 (2 fori). Flangia inclusa.
F38 flange for close coupling hydraulic motors SAE A82.55 (2 holes). Flange included.



testa in
ottone
brass
head



bielle in
alluminio
aluminium
connecting-rods

HYDRAULIC DRIVE

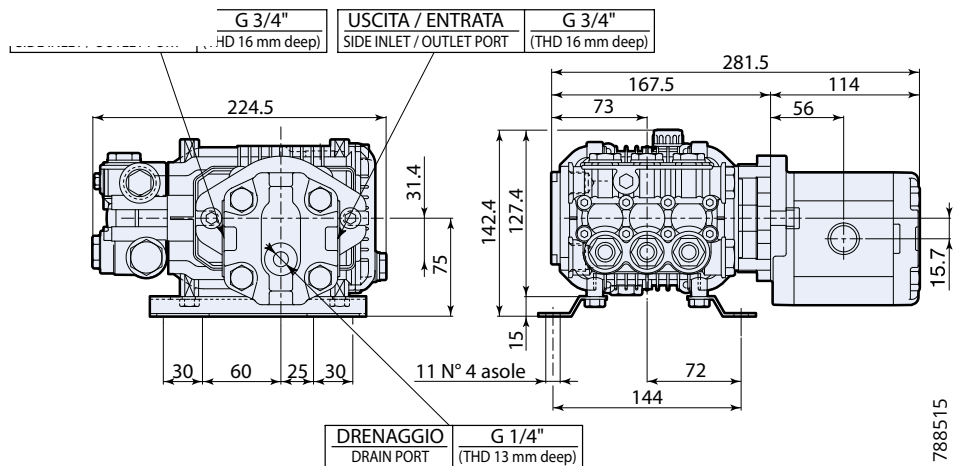

testa in
ottone
brass
head



bielle in
alluminio
aluminium
connecting-rods



motore
idraulico
hydraulic
drive

HYD - XM

MOD	COD	POMPA A PISTONI • HP PISTON PUMP					MOTORE IDRAULICO • HYDRAULIC MOTOR					NET		
		MAX	MAX	RPM			SAUER DANFOSS							
		l/min	gpm	bar	psi	N° giri/1'	hp	Type	Cod	cm ³	bar	l/min	N° giri/1'	kg

HYD-XM														
HYD-XM 15.15	21603	15	3,96	150	2200	1450	5,5	SNM2NN/019 BN06GAM1F5F5N	4769	19,2	105*	29*	1450	9,6

*) Theoretical data.

1788515

322 SERIES

RR
RRA
RRV
HRR



Corpo e coperchi in alluminio pressofuso.

Coperchio laterale con livello olio.
Coperchio posteriore con scarico olio.

Bielle in lega zinco- alluminio pressofuso o in bronzo.

Testa in ottone stampato.
Possibilità di testa in ottone stampato con valvola di regolazione integrata.
Possibilità di testa in ottone nichelata.

Pistoni in ceramica.

Crankcase and back cover in pressure die-cast aluminium alloy.

Side cover incorporated with oil sight glass. Back cover incorporated with oil drain outlet.

Connecting rods in die-cast zinc-aluminium alloy. Bronze connecting rods available.

*Pump head in forged brass.
Pump head in forged brass with integrated pressure regulating valve available.*

Nickel plated brass head available.

Ceramic plungers.

322 Series

POMPA ALBERO MASCHIO Solid shaft pump



idropultrici pressure washers	processi industriali industrial processes	autolavaggio car wash	agricoltura agriculture	cantieri ed edilizia construction industry

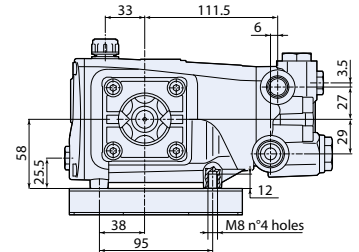
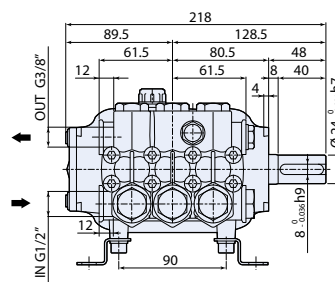
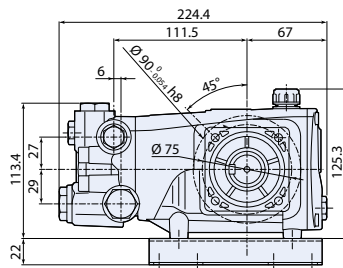

Piedi a richiesta.
Base on request.

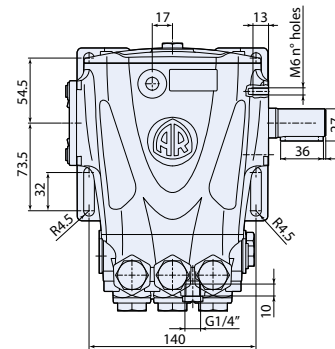

Regulating valve
version



● Model H

N version

Flangiatura compatibile XT N.
XT N flange type.

MOD	COD	MAX	gpm	bar	psi	hp	kW	N° giri/1'	kg NET
RR 1450rpm Nversion Ø24mm									
RR 13.20 N	23771	13	3,43	200	2900	7,5	5,5	1450	7,6
RR 15.15 N	23772	15	3,96	150	2200	5,5	4	1450	7,6
RR 15.20 N	23507	15	3,96	200	2900	7,5	5,5	1450	7,6
● RR 15.25 H N	● 24934	15	3,96	250	3625	10	7,5	1450	8
RR 18.12 N	23773	18	4,75	120	1740	5,5	4	1450	7,6
RR 18.16 N	23774	18	4,75	160	2300	7,5	5,5	1450	7,6
RR 20.20 N	● 29836	20	5,3	200	2900	9,5	7	1450	8
RR 21.20 N	● 29835	21	5,5	200	2900	10	7,5	1450	8
RR 22.20 N	● 29759	22	5,8	200	2900	11	8	1450	8
RRA 1750rpm Nversion Ø24mm									
RRA 3.5G25 N	23779	13,2	3,5	170	2500	6	4,5	1750	7,6
RRA 4G30 N	23780	15,1	4	205	3000	8,2	5,5	1750	7,6
● RRA 4G36 H N	● 24937	15,1	4	250	3600	8,6	6,4	1750	8
RRA 5.5G30 N	23781	20,8	5,5	205	3000	11	8,2	1750	7,6



● testa
nichelata
nickel plated
brass head



● bielle in
bronzo
bronze
connecting-rods



testa in
ottone
brass
head



● bielle in
alluminio
aluminium
connecting-rods

3228500



322 Series

POMPA ALBERO CAVO Hollow shaft pump



idropultrici
pressure
washers



processi
industriali
industrial
processes



autolavaggio
car wash



agricoltura
agriculture



cantieri ed
edilizia
construction
industry

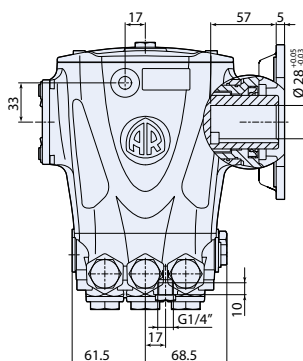
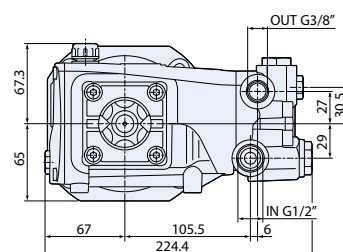
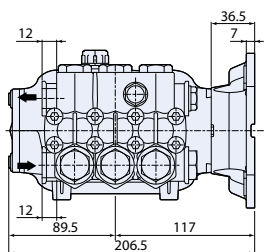
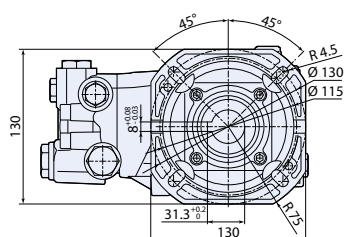

• Left hand
regulating valve
+ TSS version

3228501

C version + flange

MOD	COD	MAX	MAX						
		l/min	gpm	bar	psi	hp	kW	N° giri/1'	kg
RR 1450rpm Cversion + flange Ø28mm									
RR 13.20 C + flange Ø 28 mm	23775	13	3,43	200	2900	7,5	5,5	1450	8
• RR 13.20 C TSS + flange Ø 28 mm	28254	13	3,43	200	2900	7,5	5,5	1450	8
RR 15.15 C + flange Ø 28 mm	23776	15	3,96	150	2200	5,5	4	1450	8
RR 15.20 C + flange Ø 28 mm	23777	15	3,96	200	2900	7,5	5,5	1450	8
• RR 15.20 C TSS + flange Ø 28 mm	28251	15	3,96	200	2900	7,5	5,5	1450	8
RR 18.16 C + flange Ø 28 mm	23778	18	4,75	160	2300	7,5	5,5	1450	8

Flangia per motori elettrici B14 Gr.100÷112 IEC34-7, 4 poli 50Hz. Flangia inclusa.
Flange for electric motor B14 100÷112 IEC34-7, 4 poles 50Hz. Flange included.



testa in
ottone
brass
head



bielle in
alluminio
aluminium
connecting-rod

322 Series

POMPA ALBERO CAVO Hollow shaft pump

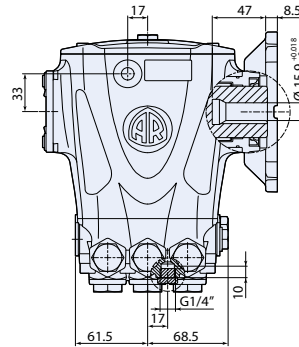
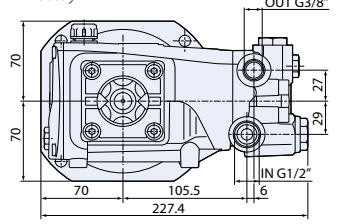
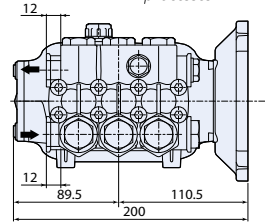
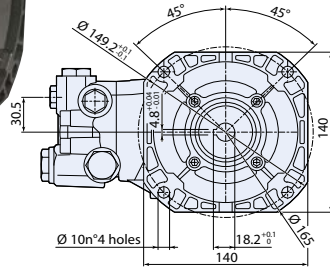

3228502

E version + flange

MOD	COD	MAX	MAX						
		l/min	gpm	bar	psi	hp	kW	N° giri/1'	kg
RRV 3400rpm Eversion + flange Ø5/8"									
RRV 3G25 E + flange Ø5/8"	23785	11,4	3	170	2500	5	3,7	3400	8
RRV 3.5G20 E + flange Ø5/8"	23786	13,2	3,5	140	2000	4,8	3,6	3400	8

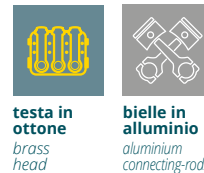

Flangia per motori elettrici NEMA 56-C, 2 poli 60Hz. Flangia inclusa.
Flange for electric motor NEMA 56-C, 2 poles 60Hz. Flange included.

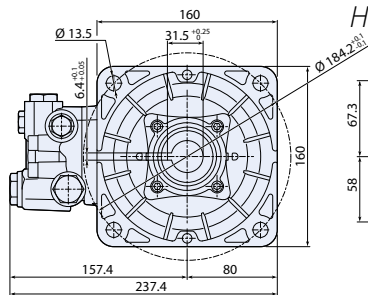

POMPA ALBERO CAVO Hollow shaft pump

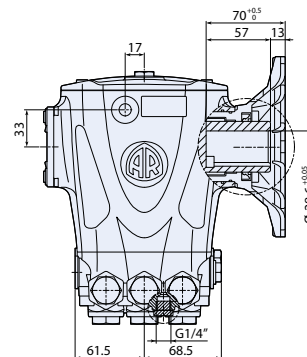
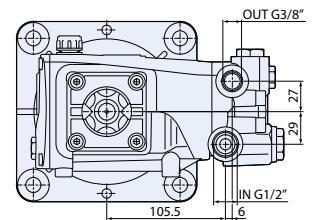
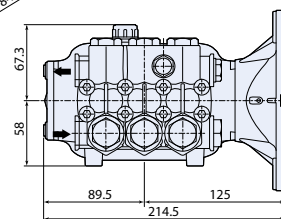

3228503



E version + flange

MOD	COD	MAX	MAX						
		l/min	gpm	bar	psi	hp	kW	N° giri/1'	kg
RRA 1750rpm Eversion + flange Ø1"1/8									
RRA 3G30 E + flange Ø1"1/8	23782	11,4	3	205	3000	6,2	4,6	1750	8
RRA 4G30 E + flange Ø1"1/8	23783	15,1	4	205	3000	8,2	6,1	1750	8
RRA 5.5G26 E + flange Ø1"1/8	23784	20,8	5,5	180	2600	10	7,5	1750	8

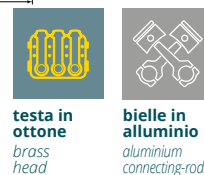

Flangia per motori elettrici NEMA 184, 4 poli 60 Hz. Flangia inclusa.
Flange for electric motor NEMA 184, 4 poles 60 Hz. Flange included.



322 Series

POMPA ALBERO CAVO Hollow shaft pump



idropulitrici
pressure
washers

processi
industriali
industrial
processes

agricoltura
agriculture

cantieri ed
edilizia
construction
industry

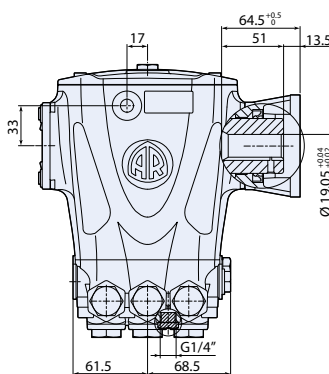
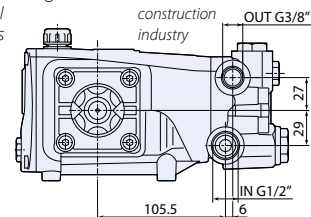
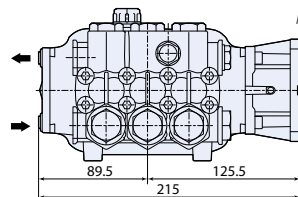
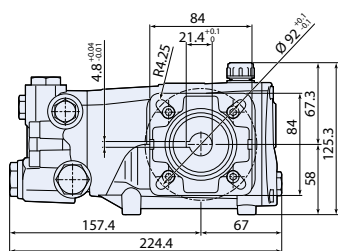

3228504

D version + flange

MOD	COD	MAX	MAX		
		l/min gpm	bar psi	hp kW	N° giri/1' kg



testa in
ottone
brass
head

bielle in
alluminio
aluminum
connecting-rod

RRV 3400rpm Dversion + flange Ø 3/4"

RRV 3G27 D + flange Ø 3/4" **23787** 11,4 3 186 2700 5,5 4 3400 8

RRV 3.5G25 D + flange Ø 3/4" **23788** 13,2 3,5 170 2500 6 4,5 3400 8

Flangia per motori scoppio Ø 3/4" SAE J609a. Flangia inclusa.
For gasoline engine flange Ø 3/4" SAE J609a. Flange included.

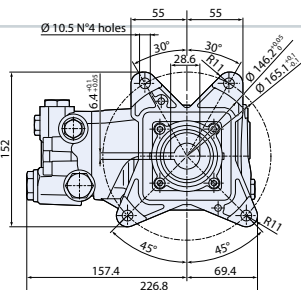

POMPA ALBERO CAVO Hollow shaft pump

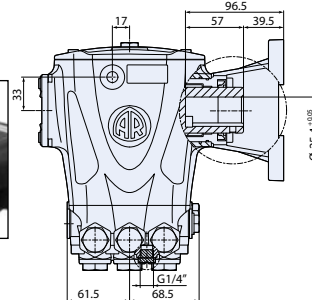
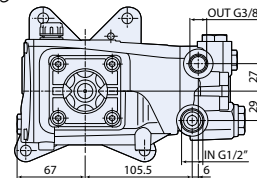
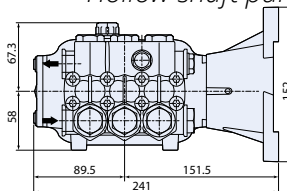

3228505



idropulitrici
pressure
washers

processi
industriali
industrial
processes

agricoltura
agriculture

cantieri ed
edilizia
construction
industry



● Model H



● Left hand
regulating valve
version

D version + flange

MOD	COD	MAX	MAX		
		l/min gpm	bar psi	hp kW	N° giri/1' kg



● testa
nichelata
nickel plated
brass head

● bielle in
bronzo
bronze
connecting-rod

testa in
ottone
brass
head

bielle in
alluminio
aluminum
connecting-rod

RRV 3400rpm Dversion + flange Ø 1"

RRV 3G30 D + flange Ø 1" **23789** 11,4 3 205 3000 6,2 4,6 3400 8

RRV 3G36 D + flange Ø 1" **23790** 11,4 3 250 3600 7,4 5,5 3400 8

RRV 3.5G36 D + flange Ø 1" **23791** 13,2 3,5 250 3600 8,6 6,4 3400 8

RRV 4G36 D + flange Ø 1" **23508** 15,1 4 250 3600 9,9 7,4 3400 8

● RRV 4G36 D + flange Ø 1" **27606** 15,1 4 250 3600 9,9 7,4 3400 8

● RRV 4G40 H D + flange Ø 1" **24935** 15,1 4 275 4000 11 8,2 3400 8,4

Flangia per motori scoppio Ø 1" SAE J609a.
Flangia inclusa.

For gasoline engine flange Ø 1" SAE J609a. Flange included.



idropultrici
pressure
washers



processi industriali
industrial
processes



autolavaggio
car wash



agricoltura
agriculture



cantieri ed edilizia
construction
industry

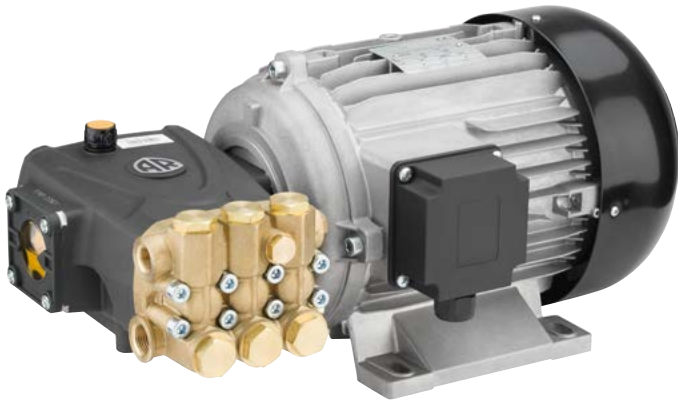

GR. 112 motor hollow shaft

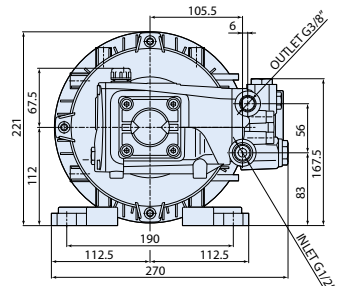
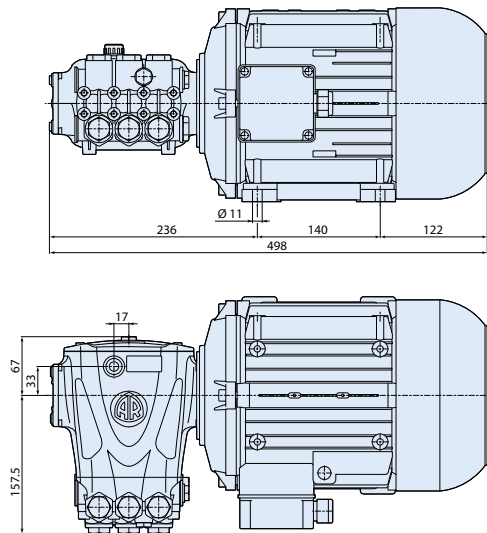

3228509

MOD	COD	MAX		MAX						KG NET	
	3 ~	l/min	gpm	bar	psi	hp	kW	N° giri/1'	V 3-50Hz	Gr.	kg
HRR 1450 rpm											
HRR 15.15 ET	23978	15	3,96	150	2200	5,5	4	1450	230/400	112	24
HRR 15.20 ET	23979	15	3,96	200	2900	7,5	5,5	1450	230/400	112	33
HRR 18.16 ET	23980	18	4,75	160	2300	7,5	5,5	1450	230/400	112	38,5



testa in ottone
brass
head



bielle in alluminio
aluminium
connecting-rods



3~50Hz
frequenza motore
motor
frequency

MADE IN ITALY

OIL



ANNOVI REVERBERI
The Power of Experience

RK 15.20H N

VOLUME 15 L./min.

PRESS. 200 bar RPM 1450



EAC

Nr. 20638 OP190123450320008

OIL SAE 30

MADE IN ITALY

62101 H



NUOVA RK
NEW RK

228 SERIES

- 1 Scritta "Made in Italy" per sottolineare la qualità italiana di sempre
"Made in Italy" to emphasize the italian quality as always
- 2 Logo AR in rilievo
Embossed trademark
- 3 Targhe dati Stampa laser
Data plates laser printed

RK
RKA
RKV
JK
JKA
RHW
RCW
HRK
RK+F38
HYD-RK



NEW



228 SERIES

RK
RKA
RKV
JK
JKA

RHW
RCW
HRK
RK+F38
HYD-RK



Corpo e coperchi in alluminio pressofuso.

Coperchio posteriore con livello olio e scarico olio. Possibilità di ulteriore livello olio laterale.

Cuscinetti a rulli conici.

Bielle in lega zinco-alluminio oppure in bronzo.

Testa in ottone stampato o in ottone nichelato.

Pistoni in ceramica.

Crankcase and back cover in pressure die-cast aluminium alloy.

Back cover incorporated with oil sight glass and oil drain outlet. Possibility of further lateral oil sight glass.

Tapered roller bearings.

Connecting rods in zinc-aluminium alloy. Bronze connecting rods available.

Pump head in forged brass or nickel-plated brass.

Ceramic plungers.

228 Series

POMPA ALBERO MASCHIO Solid shaft pump



idropultrici
pressure washers

processi industriali
industrial processes

autolavaggio
car wash

agricoltura
agriculture

municipality



cantieri ed edilizia
construction industry



● Model H

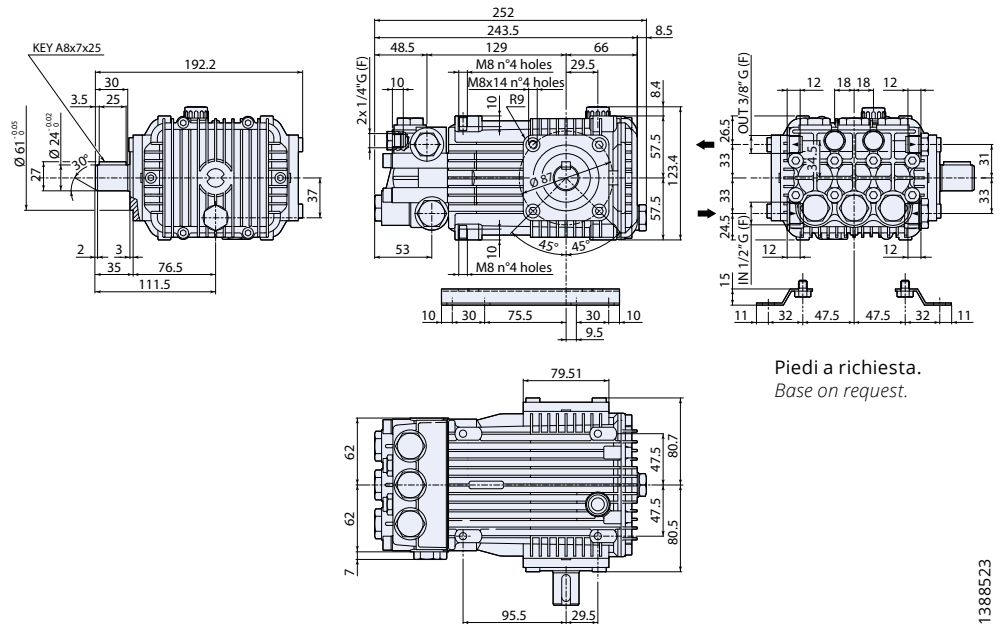

Piedi a richiesta.
Base on request.

N version

MOD	COD	MAX	gpm	bar	psi	hp	kW	N° giri/1'	KG NET
RK 1450rpm Nversion Ø24mm									
RK 11.14 N	20630	11	2,90	140	2000	4	3	1450	9
● RK 11.20 H N	20631	11	2,90	200	2900	5,5	4	1450	9
● RK 11.25 H N	● 20632	11	2,90	250	3625	7,5	5,5	1450	9,5
RK 13.17 N	20634	13	3,43	170	2500	5,5	4	1450	9
● RK 13.20 H N	20635	13	3,43	200	2900	7,5	5,5	1450	9
RK 14.16 N	20636	14	3,70	160	2300	5,5	4	1450	9
RK 15.15 N	20637	15	3,96	150	2200	5,5	4	1450	9
● RK 15.20 H N	20638	15	3,96	200	2900	7,5	5,5	1450	9
● RK 15.25 H N	● 20639	15	3,96	250	3625	10	7,5	1450	9,5
● RK 15.28 H N	● 20640	15	3,96	275	4000	11	8,2	1450	9,5
RK 18.12 N	20641	18	4,75	120	1740	5,5	4	1450	9
● RK 18.20 H N	● 20643	18	4,75	200	2900	10	7,5	1450	9,5
● RK 18.28 H N	● 21467	18	4,75	275	4000	15	11	1450	9,5
RK 21.10 N	20644	21	5,55	100	1450	5,5	4	1450	9
● RK 21.15 H N	20645	21	5,55	150	2200	7,5	5,5	1450	9
● RK 21.20 H N	● 21129	21	5,55	200	2900	10	7,5	1450	9,5
RK 24.10 N	23818	24	6,34	100	1450	6,3	4,7	1450	9
● RK 24.15 H N	● 23819	24	6,34	150	2200	9,4	7,2	1450	9,5



● **testa nichelata**
nickel plated brass head



● **bielle in bronzo**
bronze connecting-rods



● **testa in ottone**
brass head



● **bielle in alluminio**
aluminium connecting-rods

1388523



228 series

POMPA ALBERO MASCHIO Solid shaft pump



idropultrici
pressure
washers



processi
industriali
industrial
processes



autolavaggio
car wash



agricoltura
agriculture



municipality



cantieri ed
edilizia
construction
industry



● Model H

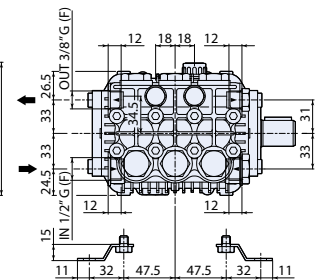
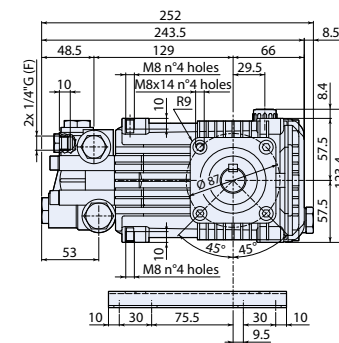
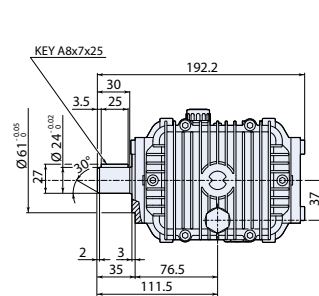

Piedi a richiesta.
Base on request.

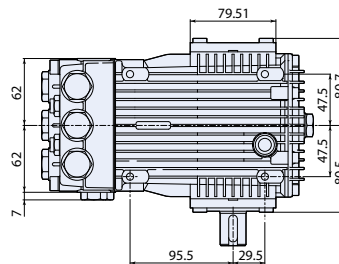

1368523

N version

MOD	COD	MAX	gpm	bar	psi	hp	kW	N° giri/1'	kg
RKA 1750rpm Nversion Ø24mm									
RKA 3.5G25 N	20659	13,2	3,5	170	2500	5	3,6	1750	9
● RKA 3.5G40 H N	● 20661	13,2	3,5	275	4000	10	7,5	1750	9,5
● RKA 4G30 H N	● 20665	15,1	4	205	3000	7,5	5,5	1750	9,5
● RKA 4G40 H N	● 20667	15,1	4	275	4000	11	8,2	1750	9,5
RKA 4.5G17 N	20668	17	4,5	115	1700	5	3,6	1750	9
● RKA 4.5G30 H N	● 20670	17	4,5	205	3000	10	7,5	1750	9,5
● RKA 4.5G40 H N	● 21130	17	4,5	275	4000	12,5	9,2	1750	9,5
RKA 5.5G13 N	20671	20,8	5,5	90	1300	5	3,6	1750	9
● RKA 5.5G20 H N	● 20672	20,8	5,5	140	2000	7,5	5,5	1750	9
● RKA 5.5G30 H N	● 21131	20,8	5,5	205	3000	11	8,2	1750	9,5
RKA 6.5G13 N	20674	25	6,6	90	1300	6	4,4	1750	9
● RKA 6.5G20 H N	● 20675	25	6,6	140	2000	9	6,8	1750	9,5
RKA 7G13 N	20676	27	7,1	90	1300	6,5	4,7	1750	9
● RKA 7G20 H N	● 20677	27	7,1	140	2000	10	7,5	1750	9,5



● testa
nichelata
nickel plated
brass head



○ bielle in
bronzo
bronze
connecting-rods



● testa in
ottone
brass
head



○ bielle in
alluminio
aluminium
connecting-rods

228 Series

POMPA ALBERO CAVO Hollow shaft pump



idropultrici
pressure
washers



**processi
industriali**
industrial
processes



autolavaggio
car wash



agricoltura
agriculture



municipality



**cantieri ed
edilizia**
construction
industry



● Model H

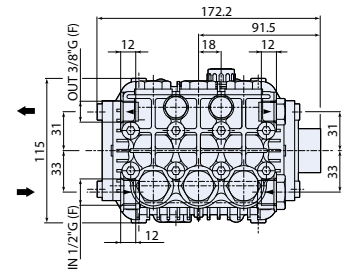
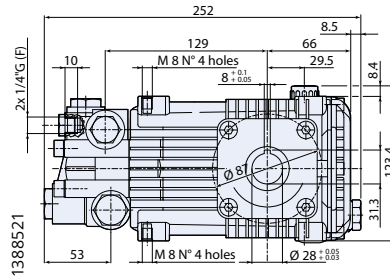

C version

MOD	COD	MAX		MAX		hp	kW	N° giri/1'	kg
		l/min	gpm	bar	psi				
RK 1450rpm Cversion Ø28mm									
● RK 11.20 H C	20647	11	2,90	200	2900	5,5	4	1450	9
RK 13.12 C	20648	13	3,43	120	1740	4	3	1450	9
RK 13.17 C	20649	13	3,43	170	2500	5,5	4	1450	9
● RK 13.20 H C	20650	13	3,43	200	2900	7,5	5,5	1450	9
RK 14.16 C	20651	14	3,70	160	2300	5,5	4	1450	9
RK 15.15 C	20652	15	3,96	150	2200	5,5	4	1450	9
● RK 15.20 H C	20653	15	3,96	200	2900	7,5	5,5	1450	9
RK 18.12 C	20654	18	4,75	120	1740	5,5	4	1450	9
● RK 18.16 H C	20655	18	4,75	160	2300	7,5	5,5	1450	9
RK 21.10 C	20656	21	5,55	100	1450	5,5	4	1450	9
● RK 21.15 H C	20657	21	5,55	150	2200	7,5	5,5	1450	9



● **testa
nichelata**
nickel plated
brass head



**testa in
ottone**
brass
head



**bielle in
alluminio**
aluminium
connecting-rods

F16 flange for electric motor B14 100±112 IEC34-7, 4 poles 50Hz. Flange not included.
Flangia F16 per motori elettrici B14 Gr.100±112 IEC34-7, 4 poli 50Hz. Flangia non inclusa.



228 series

POMPA ALBERO CAVO Hollow shaft pump



idropulitrici
pressure washers



processi industriali
industrial processes



autolavaggio
car wash



agricoltura
agriculture



municipality



cantieri ed edilizia
construction industry



● Model H

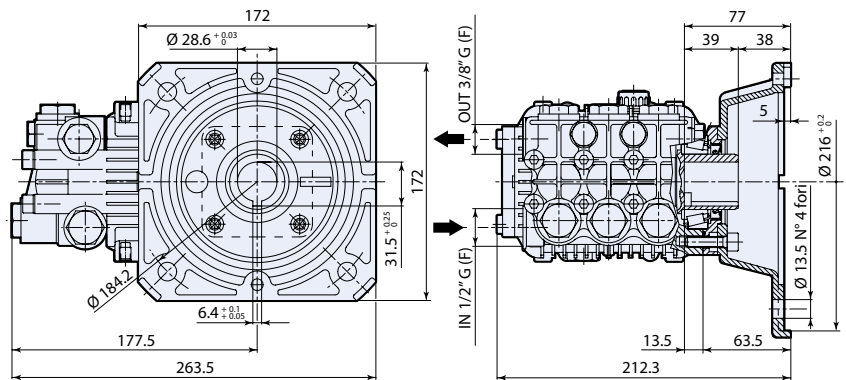

1388521

Flangia F17 fornita a richiesta.
F17 flange on request.

E version

MOD	COD	MAX		MAX		NET			
		l/min	gpm	bar	psi	hp	kW	N° giri/1'	kg
RKA 1750rpm Eversion Ø1" 1/8									
RKA 3.5G25 E	20678	13,2	3,5	170	2500	5	3,6	1750	9
● RKA 3.5G30 H E	● 20679	13,2	3,5	205	3000	7,5	5,5	1750	9,5
RKA 4G20 E	20680	15,1	4	140	2000	5	3,6	1750	9
● RKA 4G30 H E	● 20681	15,1	4	205	3000	7,5	5,5	1750	9,5
RKA 5.5G13 E	20682	20,8	5,5	90	1300	5	3,6	1750	9
RKA 6.5G13 E	● 20683	25	6,6	90	1300	6	4,4	1750	9
● RKA 6.5G20 H E	● 20684	25	6,6	140	2000	9	6,8	1750	9,5
RKA 7G13 E	20685	27	7,1	90	1300	6,5	4,7	1750	9
● RKA 7G20 H E	● 20686	27	7,1	140	2000	10	7,5	1750	9,5



● **testa nichelata**
nickel plated brass head



● **bielle in bronzo**
bronze connecting-rods



● **testa in ottone**
brass head



● **bielle in alluminio**
aluminium connecting-rods

Flangia F17 per motori elettrici NEMA 182-184, 4 poli 60Hz. Flangia non inclusa.
F17 flange for electric motor NEMA 182-184, 4 poles 60Hz. Flange not included.

228 Series

POMPA ALBERO CAVO Hollow shaft pump



Model H



idropultrici
pressure
washers



processi industriali
industrial
processes



autolavaggio
car wash



agricoltura
agriculture



municipality



cantieri ed edilizia
construction
industry



● Model H

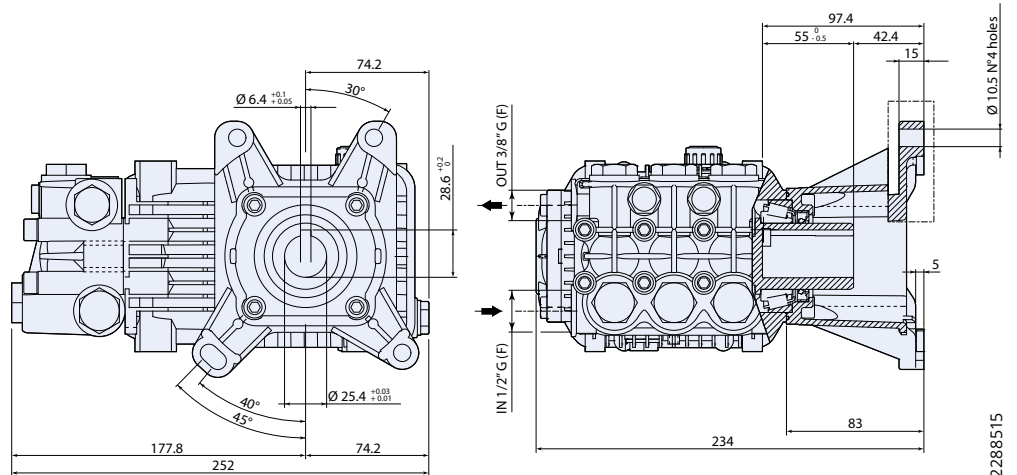

2288515

D version + F41

MOD	COD	MAX	MAX	MAX	MAX	MAX	MAX	N° giri/1'	NET
		l/min	gpm	bar	psi	hp	kW		kg
RKV 3400rpm Dversion + F41 Ø1"									
RKV 3.5G25 D + F41	20693	13,2	3,5	170	2500	5	3,6	3400	10
● RKV 3.5G30 H D + F41	● 20694	13,2	3,5	205	3000	5	3,6	3400	10,5
● RKV 3.5G40 H D + F41	● 21132	13,2	3,5	275	4000	10	7,5	3400	10
RKV 4G30 D + F41	20697	15,1	4	205	3000	7,5	5,5	3400	10,5
● RKV 4G35 H D + F41	● 20699	15,1	4	240	3500	7,5	5,5	3400	10,5
● RKV 4G40 H D + F41	● 21133	15,1	4	275	4000	11	8,2	3400	10,5
● RKV 4.5G40 H D + F41	● 21134	17	4,5	275	4000	12	8,7	3400	10,5
● RKV 5.5G40 H D + F41	● 21135	20,8	5,5	275	4000	15	11	3400	10,5



● **testa nichelata**
nickel plated
brass head



○ **bielle in bronzo**
bronze
connecting-rods



● **testa in ottone**
brass
head



○ **bielle in alluminio**
aluminium
connecting-rods

Flangia F41 per motori scoppio Ø 1" SAE J609a.
Flangia inclusa.
Flange F41 for gasoline engine Ø 1" SAE J609a.
Flange included.

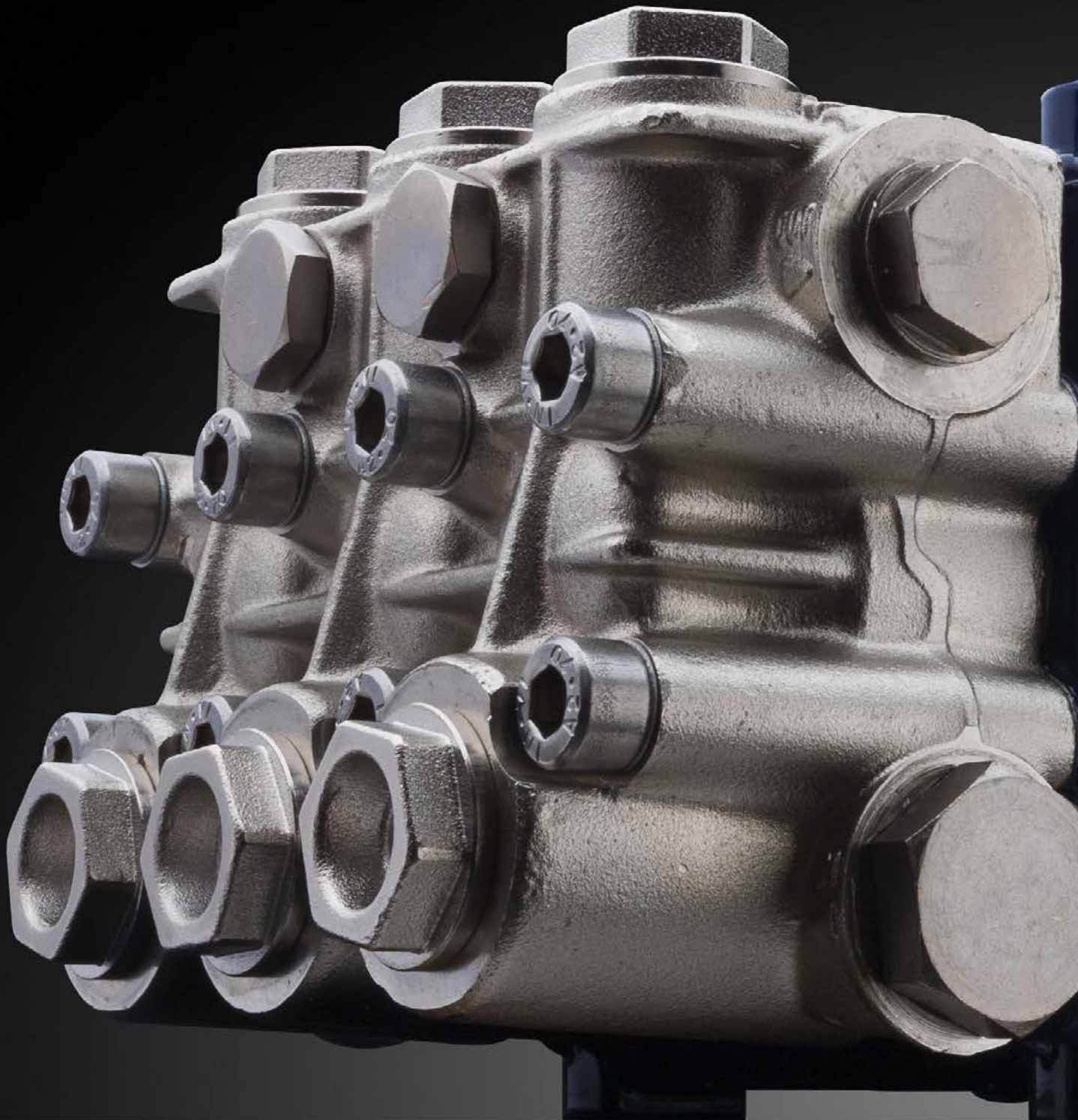

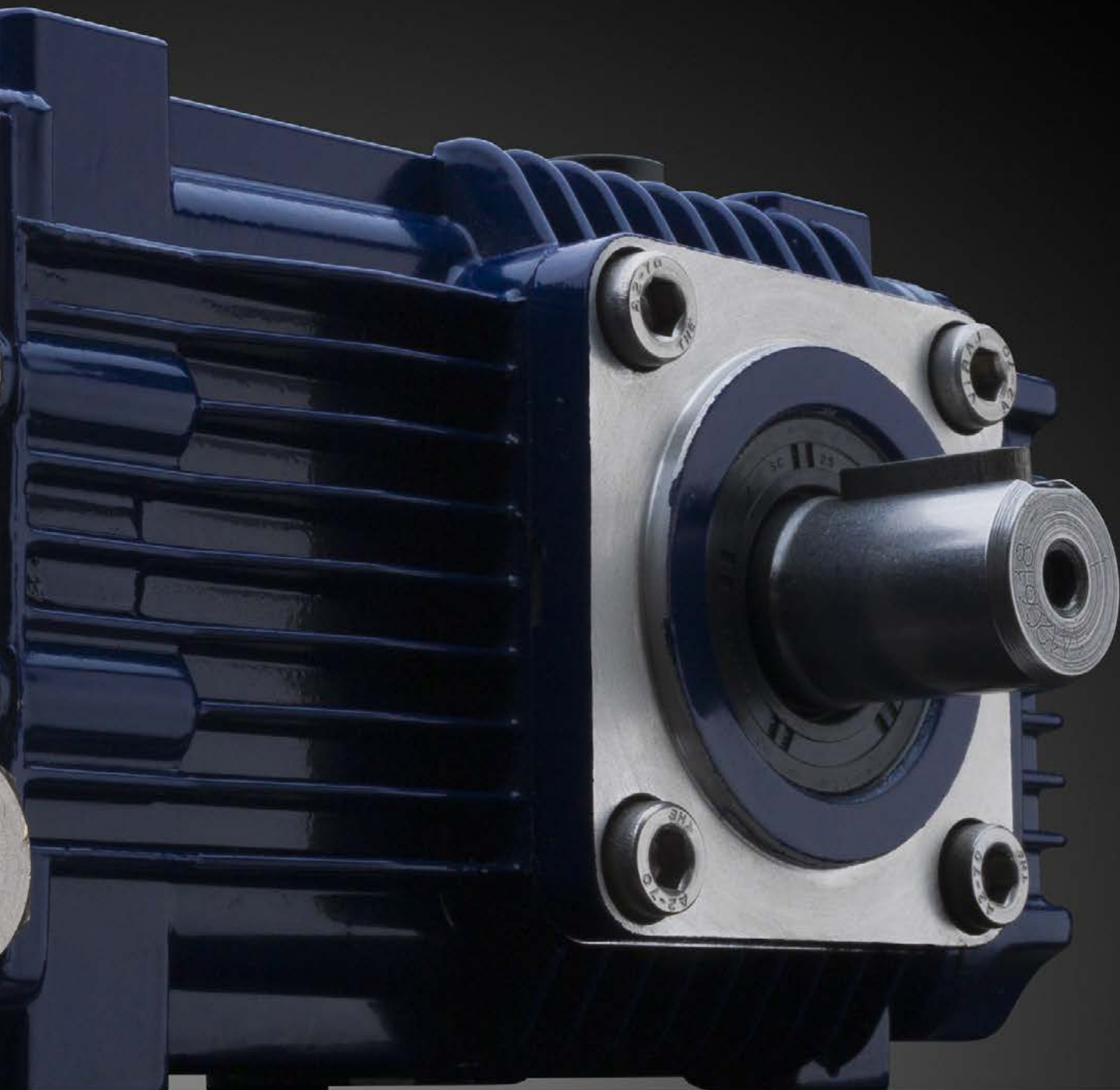

Premium Series

LOW MAINTENANCE
HIGH EFFICIENCY



228 Series

PREMIUM SERIES

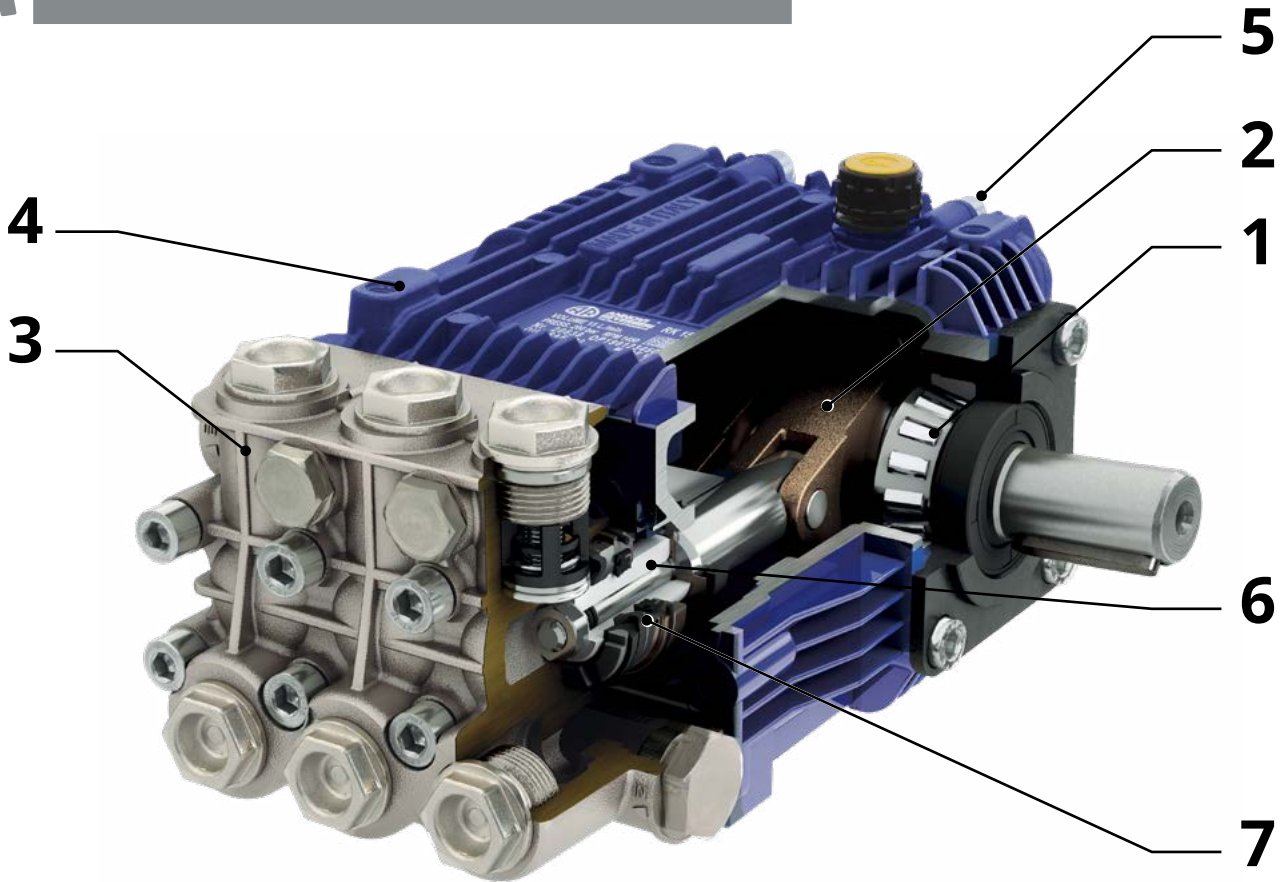

- 1** Cuscinetti a rulli conici di livello Premium.
- 2** Bielle in speciale lega in bronzo con eccellenti proprietà antifrizione e meccaniche.
- 3** Testa in ottone nichelato per una maggiore resistenza agli agenti chimici.
- 4** Corpo in lega di alluminio pressofuso con trattamento di verniciatura a polvere per una maggiore resistenza alla corrosione.
- 5** Coperchio posteriore maggiorato per contenere una maggiore quantità di olio e per garantire quindi una migliore lubrificazione.
Tappo scarico olio magnetico per raccolta di particelle metalliche provenienti dall'usura delle parti meccaniche in movimento.
- 6** Pistoni in ceramica.
Lavorazione speciale per i pistoni di guida mirata a ridurre i rischi di perdite di olio.
- 7** Doppia guarnizione Long Life per una durata maggiore e prevenire perdite di acqua.

- 1** Premium quality tapered roller bearings.
- 2** Connecting rods in a special bronze alloy with excellent low-friction and mechanical performance.
- 3** Nickel-plated brass pump head for added protection against chemicals.
- 4** Crankcase in pressure die-cast aluminium alloy with a paint treatment that increases the corrosion resistance.
- 5** Extended back cover to contain a larger amount of oil and ensure a better lubrication.
Magnetic discharge oil cap to attract all microscopic metal particles arising from heavy duty usage.
- 6** Ceramic plungers.
Special machining for plungers guide aimed at reducing the risk of oil leaks.
- 7** Long life double sealing system to ensure longer duration and prevent water leakage.



Premium Series

LOW MAINTENANCE
HIGH EFFICIENCY



idropulitrici
pressure washers



processi industriali
industrial processes



autolavaggio
car wash



agricoltura
agriculture



municipality



cantieri ed edilizia
construction industry



CAR WASH

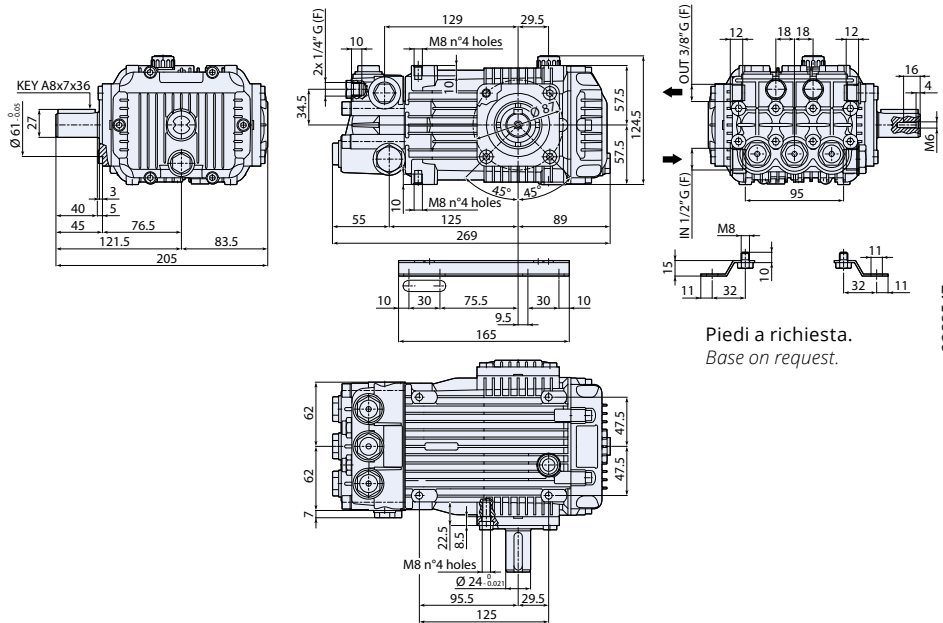

Piedi a richiesta.
Base on request.

2288547

N version

MOD	COD								
		l/min	gpm	bar	psi	hp	kW	N° giri/1'	kg
JK 1450rpm Nversion Ø24mm									
JK 11.20 H N	26781	11	2,9	200	2900	5,5	4	1450	10
JK 12.20 H N	26782	12	3,2	200	2900	5,5	4	1450	10
JK 13.12 H N	26359	13	3,43	120	1740	5,5	4	1450	10
JK 13.20 H N	26783	13	3,43	200	2900	7,5	5,5	1450	10
JK 15.15 H N	26169	15	3,96	150	2200	5,5	4	1450	10
JK 15.20 H N	23964	15	3,96	200	2900	7,5	5,5	1450	10
JK 18.16 H N	26779	18	4,75	160	2300	7,5	5,5	1450	10
JK 21.15 H N	26780	21	5,55	150	2200	7,5	5,5	1450	10
JKA 1750rpm Nversion Ø24mm									
JKA 4G30 H N	26531	15,1	4	205	3000	7,5	5,5	1750	10



testa nichelata
nickel plated
brass head



bielle in bronzo
bronze
connecting-rods



228 series

POMPA ALBERO MASCHIO Solid shaft pump



idropulitrici
pressure
washers



processi
industriali
industrial
processes



autolavaggio
car wash



agricoltura
agriculture



cantieri ed
edilizia
construction
industry

CAR WASH

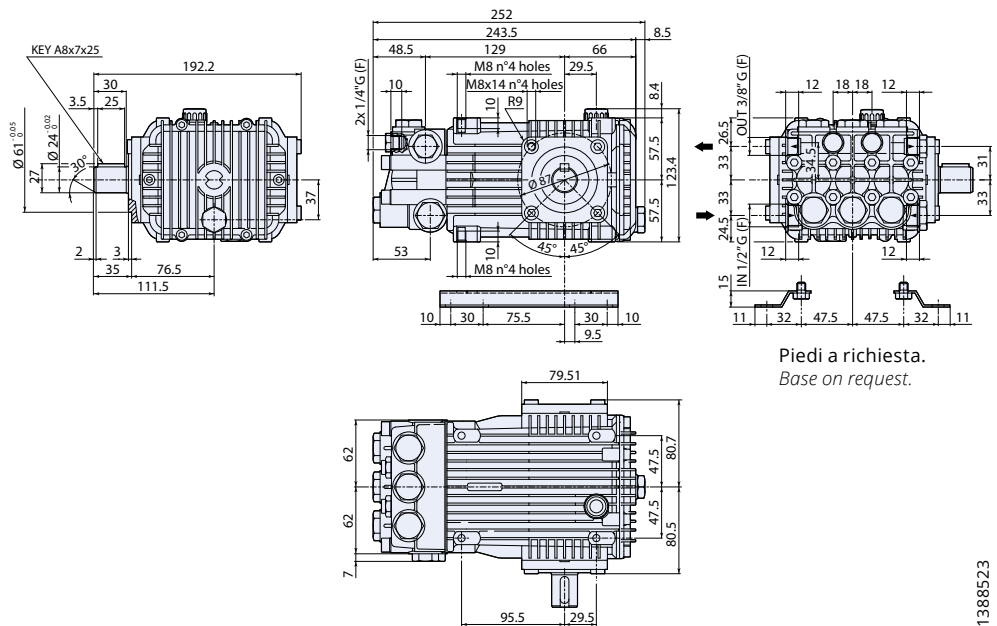

Piedi a richiesta.
Base on request.

1388523

N version

MOD	COD	 MAX	 MAX	 MAX	 MAX	 MAX	 MAX	 MAX	 NET
		l/min	gpm	bar	psi	hp	kW	N° giri/1'	kg
RCW 950rpm Nversion Ø24mm									
RCW 10.15 N	20825	10	2,64	150	2200	4	3	950	9,5
RCW 15.14 N	20826	15	3,96	140	2000	5,5	4	950	9,5
RCW 1450rpm Nversion Ø24mm									
RCW 11.10 N	20827	11	2,90	100	1450	3	2,2	1450	9,5
RCW 15.15 N	20828	15	3,96	150	2200	5,5	4	1450	9,5
RCW 15.20 N	20833	15	3,96	200	2900	7,5	5,5	1450	9,5



testa
nichelata
nickel plated
brass head



bielle in
bronzo
bronze
connecting-rod



autolavaggio
car wash municipality
car wash



HOT WATER 85°C

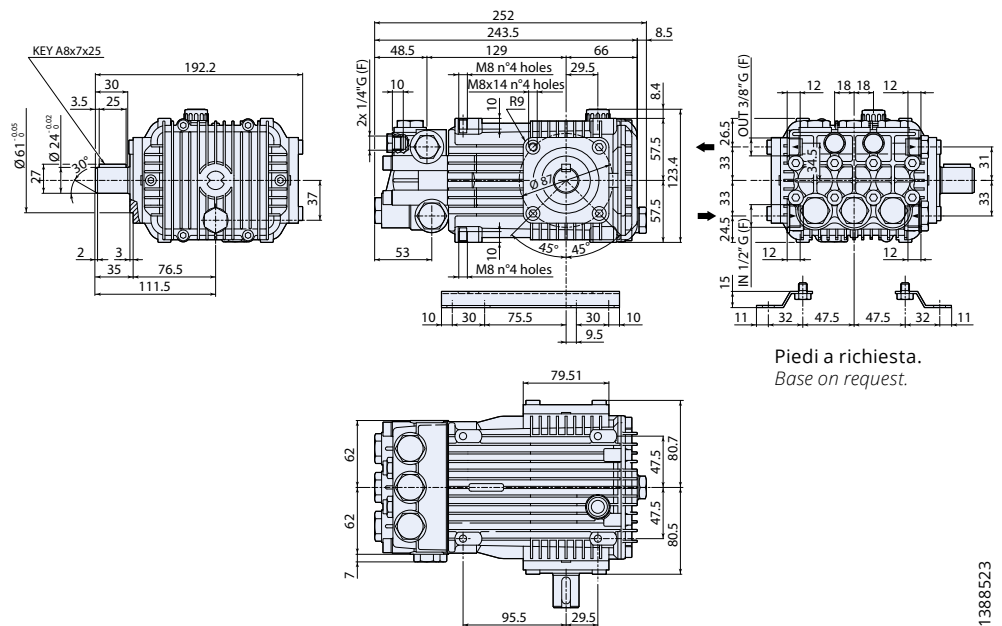

Piedi a richiesta.
Base on request.

1368523

N version

MOD	COD	MAX	MAX		NET				
		l/min	gpm	bar	psi	hp	kw	N° giri/1'	kg
RHW 950rpm Nversion Ø24mm									
RHW 10.15 N	22345	10	2,64	150	2200	4	3	950	9,5
RHW 1450rpm Nversion Ø24mm									
RHW 13.12 N	22342	13	3,43	120	1740	4	3	1450	9,5
RHW 13.17 N	22343	13	3,43	170	2500	5,5	4	1450	9,5
RHW 15.15 N	22344	15	3,96	150	2200	5,5	4	1450	9,5



testa
nichelata
nickel plated
brass head



MAX
85°



PTFE
guarnizioni
in PTFE
PTFE gasket
sealing



bielle in
bronzo
bronze
connecting-rods



228 Series

ELECTRIC MOTOR-PUMP UNITS

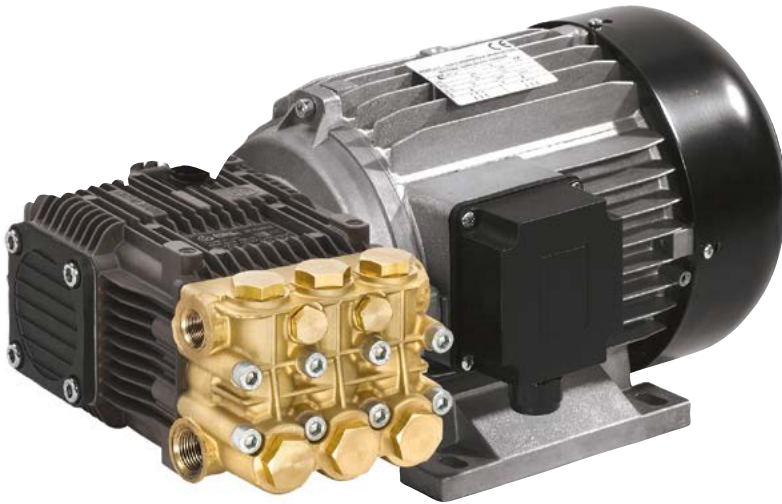

idropulitrici
pressure
washers

processi industriali
industrial
processes

autolavaggio
car wash

agricoltura
agriculture

industria alimentare
food
industry



cantieri ed edilizia
construction
industry

GR. 112 motor hollow shaft



● Model H

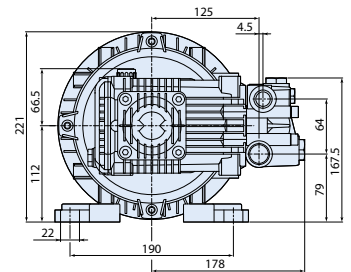
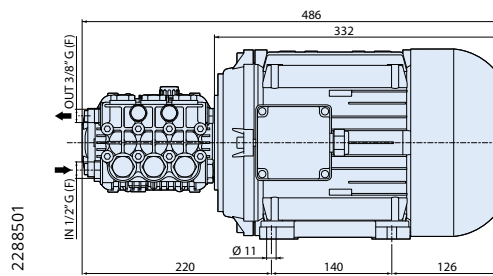

GR. 132 S motor hollow shaft

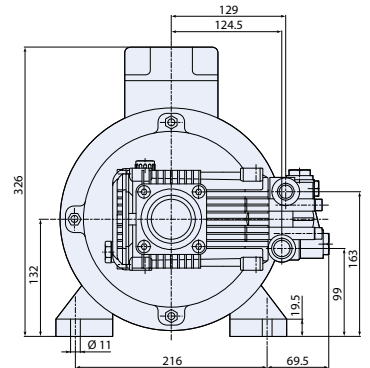
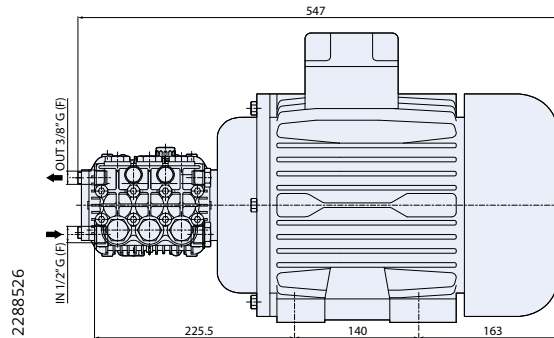

MOD	COD	3 ~	MAX	MAX	MAX	MAX	MAX	MAX	MAX	MAX	MAX
		l/min	gpm	bar	psi	hp	kW	N° giri/1'	V 3-50Hz	Gr.	kg
HRK 1450rpm											
● HRK 13.20 H ET	20859	13	3,43	200	2900	7,5	5,5	1450	230/400	112	41
HRK 14.16 ET	20860	14	3,70	160	2300	5,5	4	1450	230/400	112	32
HRK 15.15 ET	20861	15	3,96	150	2200	5,5	4	1450	230/400	112	32
● HRK 15.20 H ET	20862	15	3,96	200	2900	7,5	5,5	1450	230/400	112	41
● HRK 15.25 H ET	● 20863	15	3,96	250	3625	10	7,5	1450	230/400	132 S	56
● HRK 18.16 H ET	20865	18	4,75	160	2300	7,5	5,5	1450	230/400	112	41
HRK 21.10 ET	20866	21	5,55	100	1450	5,5	4	1450	230/400	112	32
● HRK 21.15 H ET	20867	21	5,55	150	2200	7,5	5,5	1450	230/400	112	41
● HRK 21.20 H ET	● 20868	21	5,55	210	2900	10	7,5	1450	230/400	132 S	56



● **testa nichelata**
nickel plated
brass head



○ **bielle in bronzo**
bronze
connecting-rods



● **testa in ottone**
brass
head



○ **bielle in alluminio**
aluminium
connecting-rods



3~50Hz
frequenza motore
motor
frequency



municipality

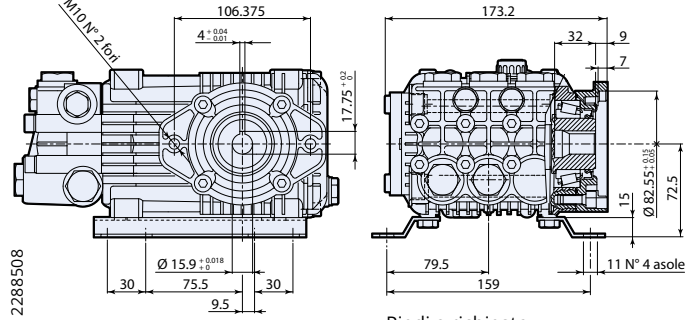

Piedi a richiesta.
Base on request.

RK + F38

MOD	COD	MAX	MAX	MAX	MAX					
		l/min	gpm	bar	psi	hp	kW	N° giri/1'	kg	NET



testa in ottone
brass head



bielle in alluminio
aluminium connecting-rods

RK 1450rpm + F38

RK 15.15 + F38	21599	15	3,96	150	2200	5,5	4	1450	9,2
RK 15.20 + F38	21600	15	3,96	200	2900	7,5	5,5	1450	9,2
RK 21.15 + F38	22086	21	5,55	150	2200	7,5	5,5	1450	9,2

Flangia F38 per motori idraulici SAE A82.55 (2 fori). Flangia inclusa.
F38 flange for close coupling hydraulic motors SAE A82.55 (2 holes). Flange included.

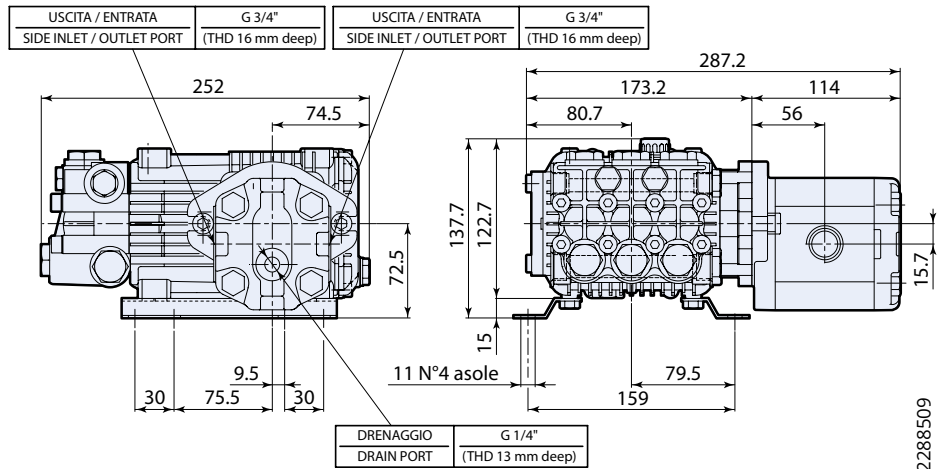

2288509



municipality



antincendio
fire fighting



testa in ottone
brass head



bielle in alluminio
aluminium connecting-rods



motore idraulico
hydraulic drive

HYD - RK

MOD	COD	POMPA A PISTONI • HP PISTON PUMP						MOTORE IDRAULICO • HYDRAULIC MOTOR						
		MAX	MAX	MAX	MAX	RPM		SAUER DANFOSS (*)		MAX	MAX	RPM		
		l/min	gpm	bar	psi	N° giri/1'	hp	Type	Cod	cm ³	bar	l/min	N° giri/1'	kg

HYD-RK

HYD-RK 15.15	21604	15	3,96	150	2200	1450	5,5	SNM2NN/019 BN06GAM1F5F5N	4769	19,2	105**	29**	1450	12,5
HYD-RK 15.20	21605	15	3,96	200	2900	1450	7,5	SNM2NN/019 BN06GAM1F5F5N	4769	19,2	140**	29**	1450	12,5
HYD-RK 21.15	22087	21	5,55	150	2200	1450	7,5	SNM2NN/019 BN06GAM1F5F5N	4769	19,2	150**	29**	1450	12,5

*) A richiesta disponibili motori idraulici Casappa - Marzocchi

*) On request available Hydraulic Motor type: Casappa - Marzocchi

***) Theoretical data.



228 Series

GASOLINE MOTOR-PUMP UNITS



- 
idropulitrici
pressure washers
- 
processi industriali
industrial processes
- 
autolavaggio
car wash
- 
agricoltura
agriculture
- 
cantieri ed edilizia
construction industry

RKV 3400 rpm Direct Drive from Honda engine

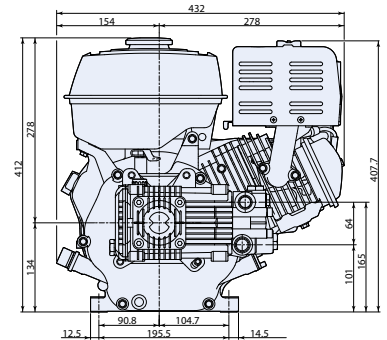
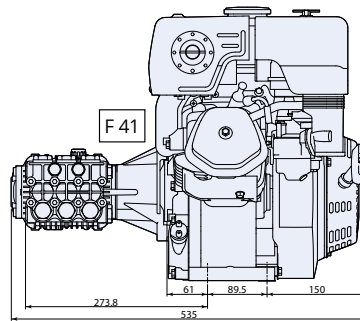

RKV 4G20 Honda GX270

22885.27

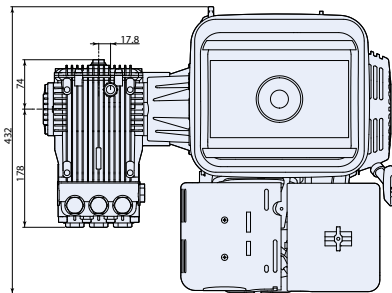

● Model H

MOD	COD	MAX	MAX	RPM	KG NET			
	Engine HP	l/min	gpm	bar	psi	N° giri/1' pompa	kg	
RKV Direct Drive								
RKV 4G20 HONDA GX 270-QX Type	8,4	20880	15,1	4	140	2000	3400	35
● RKV 4G30 H HONDA GX 270-QX Type	● 8,4	20882	15,1	4	205	3000	3400	35,5



● **testa nichelata**
nickel plated brass head



● **bielle in bronzo**
bronze connecting-rods



testa in ottone
brass head



bielle in alluminio
aluminium connecting-rods



motore a scoppio
gasoline engine



- 
idropultrici
pressure washers
- 
processi industriali
industrial processes
- 
autolavaggio
car wash
- 
agricoltura
agriculture
- 
cantieri ed edilizia
construction industry

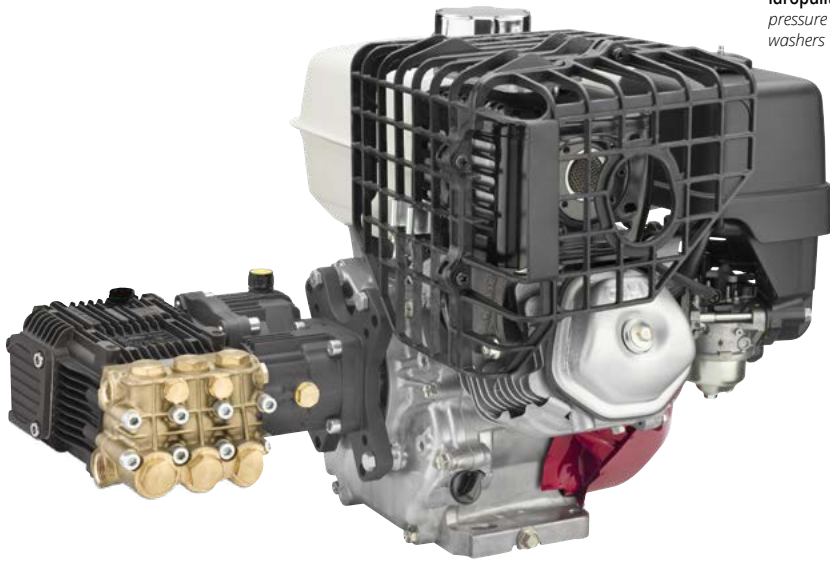

RK 15.15 CR S
(Honda engine)

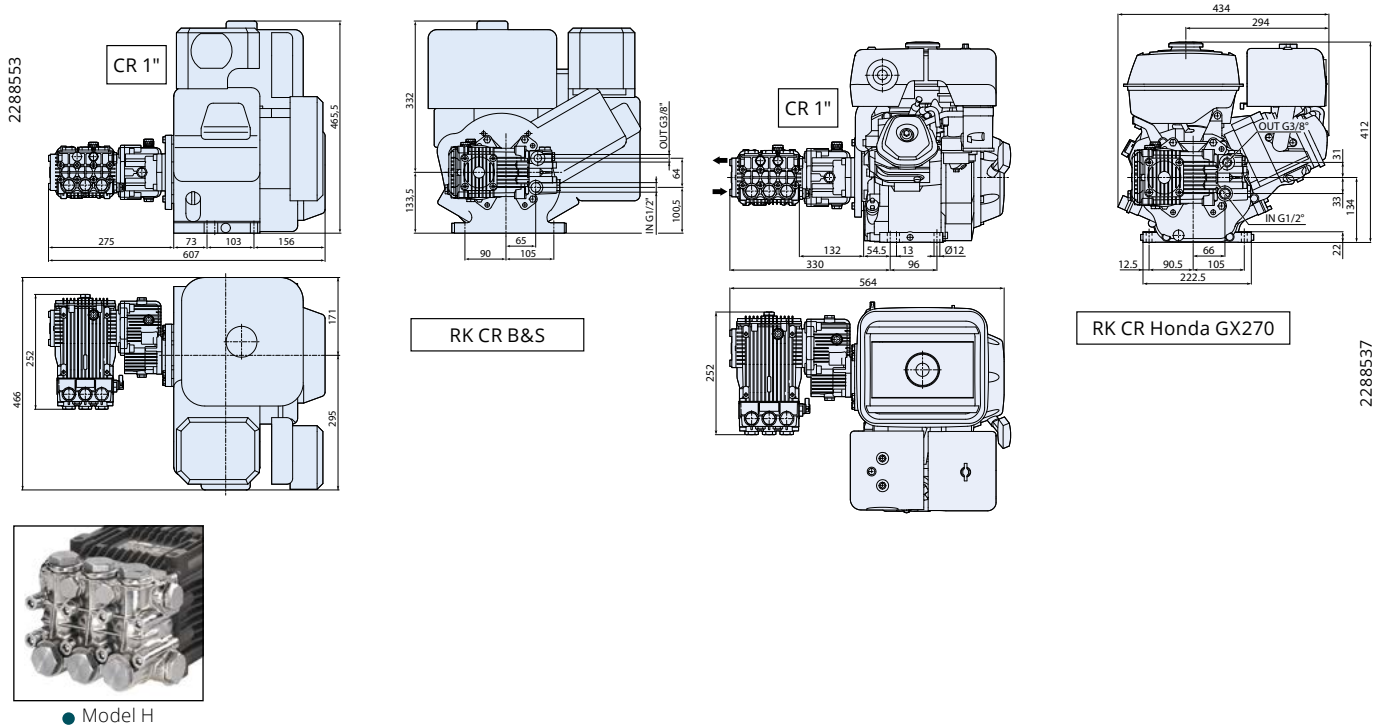

● Model H

MOD	COD	MAX	MAX	RPM	KG NET		
	Engine HP	l/min	gpm	bar	psi	N° giri/1' pompa	kg
RK Gearbox Drive							
RK 15.15 CR HONDA GX 270-QX Type	8,4 20885	15	3,96	150	2200	1450	38
● RK 15.20 H CR HONDA GX 270-QX Type	8,4 20887	15	3,96	200	2900	1450	38
● RK 15.20 H CR B&S VANGUARD	13 20886	15	3,96	200	2900	1450	46

- 

● **testa nichelata**
nickel plated brass head
- 

bielle in alluminio
aluminium connecting-rods
- 

testa in ottone
brass head
- 

motore a scoppio
gasoline engine

402 SERIES

RG
RGA
RGL
RGP
SRG

RGX
RGXA



Corpo e coperchi in alluminio pressofuso.
Coperchio laterale con livello olio.
Coperchio posteriore con scarico olio.
Cuscinetti a rulli conici.
Bielle in lega zinco-alluminio pressofuso.
Testa in ottone stampato. Possibilità di testa in ottone nichelata.
Pistoni in ceramica.

*Crankcase and cover in pressure die-cast aluminium alloy.
Side cover incorporated with oil sight glass.
Back cover incorporated with oil drain outlet.
Tapered roller bearings.
Connecting rods in die-cast zinc-aluminium alloy.
Pump head in forged brass. Nickel-plated brass head available.
Ceramic plungers.*

402 Series

POMPA ALBERO MASCHIO Solid shaft pump



lavaggio industriale
industrial cleaning



idropulitrici
pressure washers



processi industriali
industrial processes



autolavaggio
car wash



agricoltura
agriculture



cantieri ed edilizia
construction industry



antincendio
fire fighting



● Model H

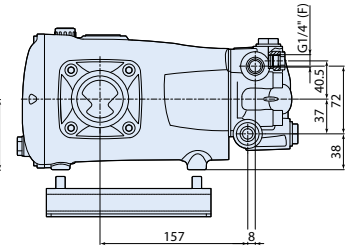
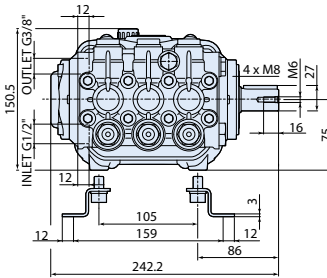
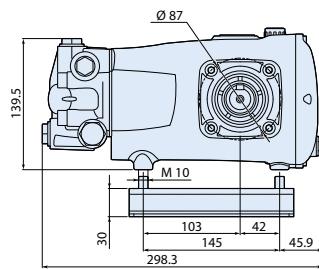



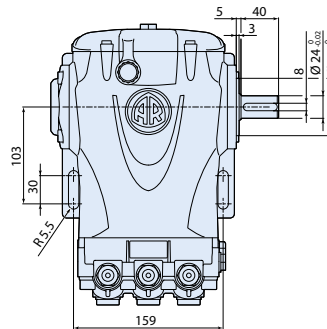





Piedi a richiesta.
Base on request.



4028500

N version

MOD	COD	 MAX	 MAX	 MAX	 MAX				
		l/min	gpm	bar	psi	hp	kW	N° giri/1'	kg
RG 1450rpm Nversion Ø24mm									
RG 13.17 N	25399	13	3,43	170	2500	5,5	4	1450	14
RG 15.15 N	24962	15	3,96	150	2200	5,5	4	1450	14
● RG 15.20 H N	25400	15	3,96	200	2900	7,5	5,5	1450	14,5
● RG 15.25 H N	25401	15	3,96	250	3625	10	7,5	1450	14,5
RG 18.17 N	25402	18	4,75	170	2500	7,5	5,5	1450	14
● RG 18.20 H N	25403	18	4,75	200	2900	10	7,5	1450	14,5
RG 21.15 N	25404	21	5,55	150	2200	7,5	5,5	1450	14
● RG 21.20 H N	25405	21	5,55	200	2900	10	7,5	1450	14,5
● RG 21.25 H N	25406	21	5,55	250	3625	12,5	9,2	1450	14,5
RG 24.15 N	25943	24	6,34	150	2200	7,5	5,5	1450	14,5
RGA 1750rpm Nversion Ø24mm									
RGA 4G22 N	25407	15,1	4	150	2200	5,5	4	1750	14
● RGA 4G30 H N	25408	15,1	4	205	3000	7,5	5,5	1750	14,5
RGA 5.5G22 N	25409	20,8	5,5	150	2200	7,5	5,5	1750	14,5
● RGA 5.5G30 H N	25410	20,8	5,5	205	3000	10	7,5	1750	14,5



● **testa nichelata**
nickel plated brass head



testa in ottone
brass head



bielle in alluminio
aluminium connecting-rods



402 Series

POMPA ALBERO MASCHIO Solid shaft pump



lavaggio industriale
industrial cleaning



idropultrici
pressure washers



processi industriali
industrial processes



autolavaggio
car wash



agricoltura
agriculture



cantieri ed edilizia
construction industry





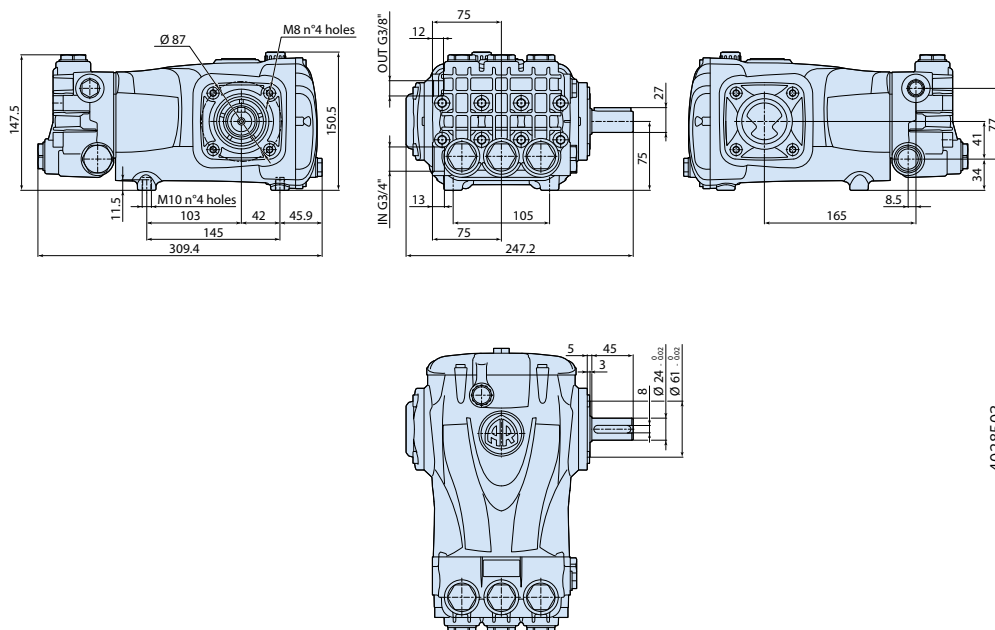

antincendio
fire fighting



4028503

N version

MOD	COD	 MAX	 MAX						
		l/min	gpm	bar	psi	hp	kW	N° giri/1'	kg
RG 1450rpm Nversion Ø24mm									
RG 30.25 N	27368	30	7.92	250	3625	19	14	1450	16

NEW



testa in ottone
brass head



bielle in alluminio
aluminium connecting-rods

402 Series

POMPA ALBERO MASCHIO Solid shaft pump





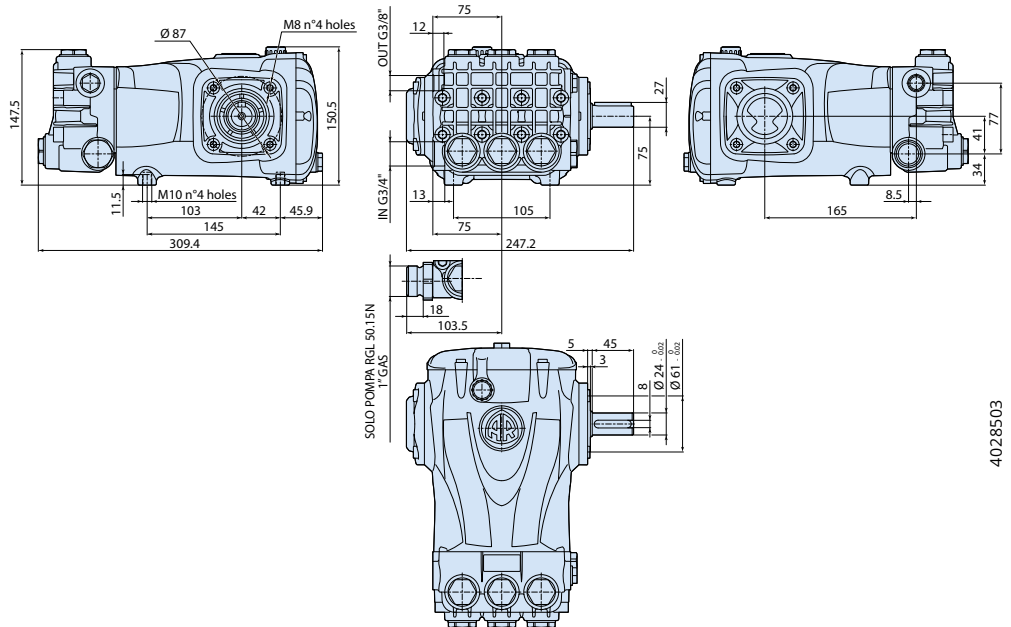

- 
lavaggio industriale
industrial cleaning
- 
processi industriali
industrial processes
- 
autolavaggio
car wash
- 
produzione
manufacturing
- 
agricoltura
agriculture
- 
municipality
- 
misting
- 
pulizia tubazioni
sewer jetting
- 
cantieri ed edilizia
construction industry



4028503

N version

MOD	COD	 MAX	 MAX						
		l/min	gpm	bar	psi	hp	kW	N° giri/1'	kg
RGL 1450rpm Nversion Ø24mm									
RGL 36.15 N	28052	36	9.51	150	2200	15	11	1450	16
RGL 41.15 N	27945	41	10.8	150	2200	16	11,8	1450	16
RGL 41.17 N	27951	41	10.8	170	2465	20	15	1450	16
RGL 41.20 N 	27370	41	10.8	200	2900	20	15	1450	16,5
RGL 42.10 N	27604	42	11.09	100	1450	11	8,2	1450	16
RGL 42.15 N	28053	42	11.09	150	2200	16	11,8	1450	16
RGL 50.15 N	27369	50	13.2	150	2175	20	15	1450	16
RGL 50.17 N	27938	50	13.2	170	2465	20	15	1450	16

- 
- 
testa in ottone
brass head
- 
bielle in bronzo
bronze connecting-rods
- 
bielle in alluminio
aluminium connecting-rods



402 Series

POMPA ALBERO MASCHIO Solid shaft pump



lavaggio industriale
industrial cleaning



processi industriali
industrial processes



autolavaggio
car wash



produzione
manufacturing



agricoltura
agriculture



municipality



misting



pulizia tubazioni
sewer jetting





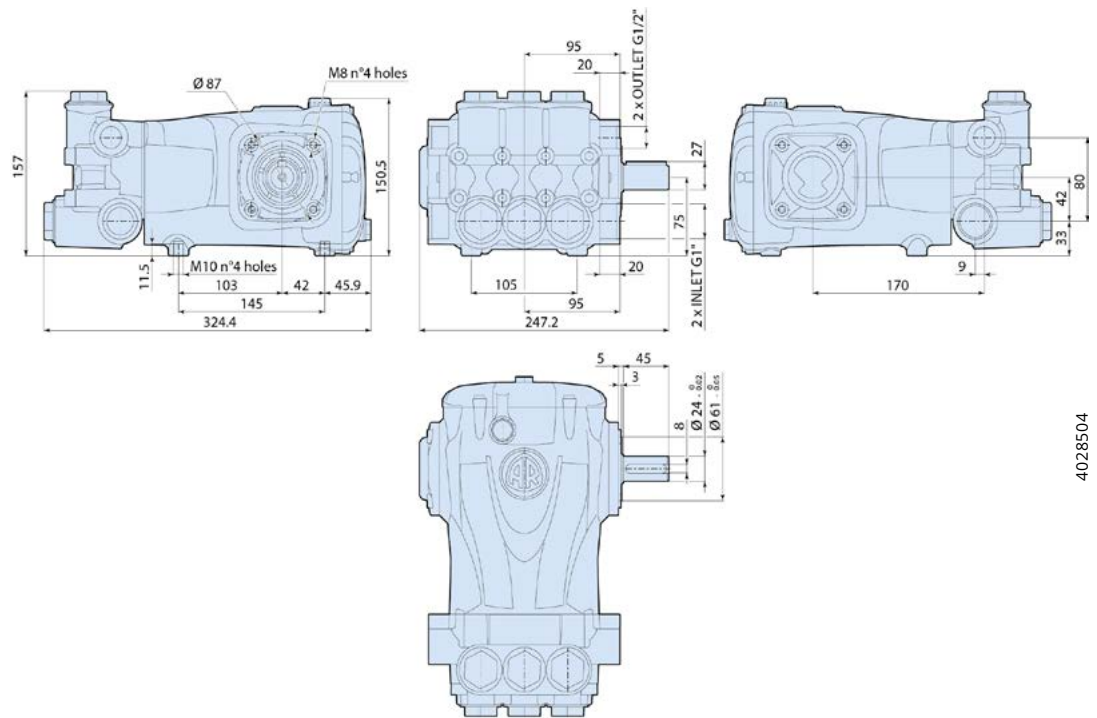

cantieri ed edilizia
construction industry



4028504

N version

MOD	COD	 MAX	 MAX		
		l/min gpm	bar psi	hp kW	N° giri/1' kg
RGP 1450rpm Nversion Ø24mm					
RGP 50.15 N	28054	50 13.2	150 2200	20 15	1450 17,6
RGP 60.13 N	28055	60 15.9	130 1900	20 15	1450 17,6
RGP 70.15 N	27371	70 18.5	150 2200	27 20	1450 17,6

A richiesta testa nichelata · Nickel plated head available.

NEW



testa in ottone
brass head



bielle in alluminio
aluminium connecting-rods

402 Series

POMPA ALBERO MASCHIO
Solid shaft pump



- lavaggio industriale**
industrial cleaning
- idropultrici**
pressure washers
- processi industriali**
industrial processes
- autolavaggio**
car wash
- produzione**
manufacturing
- agricoltura**
agriculture
- municipality**
- misting**
- pulizia tubazioni**
sewer jetting
- cantieri ed edilizia**
construction industry
- antincendio**
fire fighting

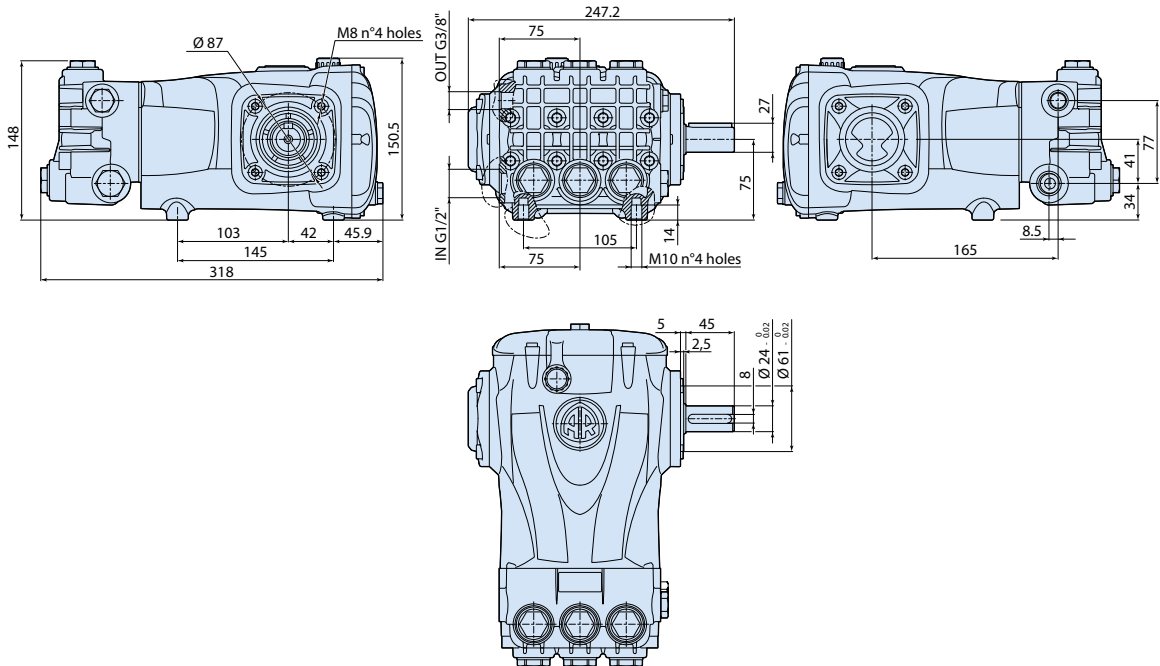

4028506

N version

MOD	COD	MAX	MAX						
		l/min	gpm	bar	psi	hp	kW	N° giri/1'	kg
SRG 1450 rpm Nversion Ø24mm									
SRG 15.35 N	27696	15	3,96	350	5100	15	11	1450	16
SRG 21.35 N	27697	21	5,54	350	5100	20	15	1450	16
SRG 30.35 N	28032	30	7,92	350	5100	30	22	1450	16

NEW



testa in ottone
brass head



bielle in alluminio
aluminium connecting-rods



RGX
RGXA

402 SERIES

Derivata dalla RG ma con testa di nuovo disegno per poter raggiungere pressioni più elevate grazie al posizionamento delle valvole di aspirazione sopra ai pistoni. Pompa a facile manutenzione grazie all'architettura della nuova testa.

Pump derived from the existing RG series pumps with a new-design head with the suction valves placed above the plungers to generate higher-than-normal pressures. The new head configuration simplifies pump maintenance.



402 Series

POMPA ALBERO MASCHIO Solid shaft pump



lavaggio industriale
industrial cleaning



idropultrici
pressure washers



processi industriali
industrial processes



agricoltura
agriculture



municipality



cantieri ed edilizia
construction industry



antincendio
fire fighting

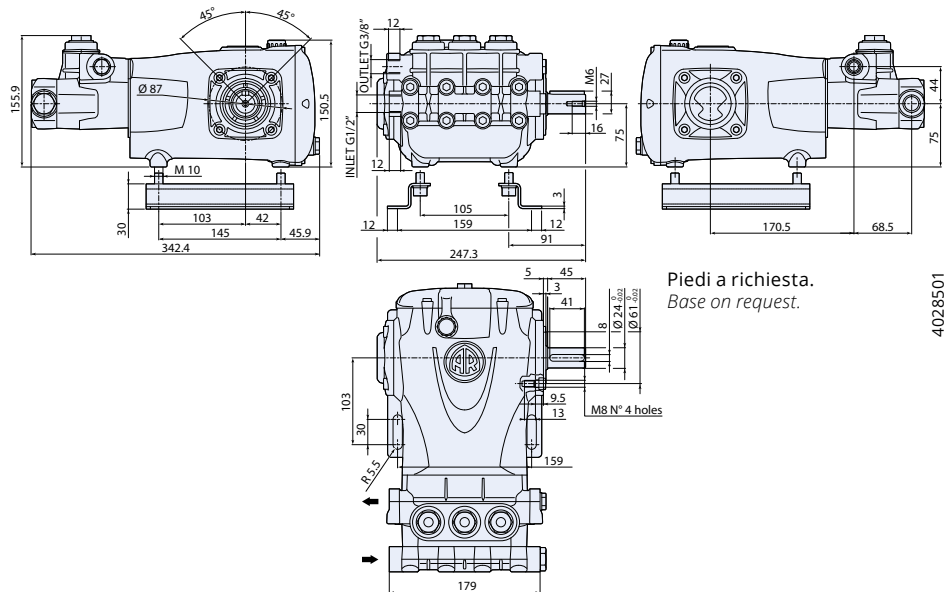

N version

MOD	COD	MAX		MAX		MAX		KG NET
		l/min	gpm	bar	psi	hp	kW	N° giri/1'
RGX 1450rpm Nversion Ø24mm								
RGX 15.50 N	25514	15	3,96	500	7250	20	15	1450
RGX 22.50 N	25638	22	5,8	500	7250	27	20	1450
● RGX 22.60 N	29026	22	5,8	600	8700	33	25	1450
RGXA 1750rpm Nversion Ø24mm								
RGXA 4G70 N	25639	15,1	4	500	7250	20	15	1750



testa in ottone
brass head



bielle in alluminio
aluminium connecting-rods



● **testa nichelata**
nickel plated brass head

298 SERIES

RW
RWA
HRW



Corpo e coperchi in alluminio pressofuso con scritta "Made in Italy" per sottolineare la qualità italiana di sempre, logo AR in rilievo e targa dati stampata col laser.

Coperchi in alluminio pressofuso

Coperchio laterale con livello olio.

Coperchio posteriore con scarico olio.

Cuscinetti a rulli conici.

Bielle in lega zinco-alluminio pressofuso.

Testa in ottone stampato. Possibilità di testa in ottone nichelata.

Pistoncini in ceramica.

Crankcase and cover in pressure die-cast aluminium alloy with impressed "Made in Italy" to emphasize the Italian quality as always, embossed trademark and data plate laser printed.

Cover in pressure die-cast aluminium alloy

Side cover incorporated with oil sight glass.

Back cover incorporated with oil drain outlet.

Tapered roller bearings.

Connecting rods in die-cast zinc-aluminium alloy.

Pump head in forged brass. Nickel-plated brass head available.

Ceramic plungers.

298 Series

POMPA ALBERO MASCHIO Solid shaft pump



- lavaggio industriale**
industrial cleaning
- idropulitrici**
pressure washers
- processi industriali**
industrial processes
- autolavaggio**
car wash
- produzione**
manufacturing
- agricoltura**
agriculture
- municipality**
- misting**
- pulizia tubazioni**
sewer jetting
- cantieri ed edilizia**
construction industry
- antincendio**
fire fighting



● Model H

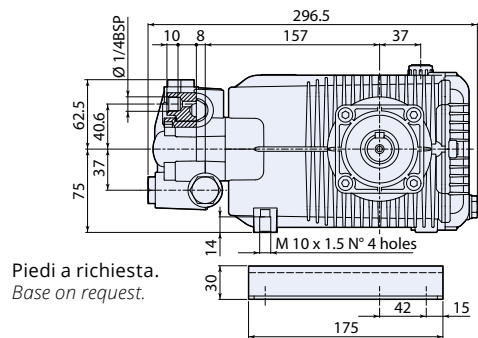

Piedi a richiesta.
Base on request.

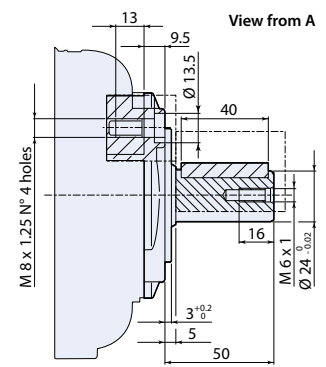
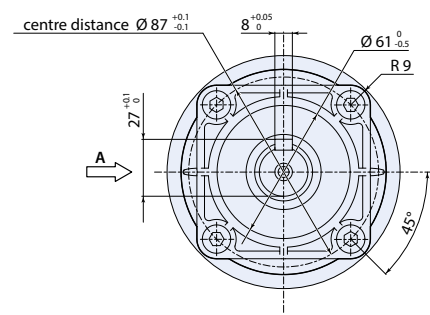
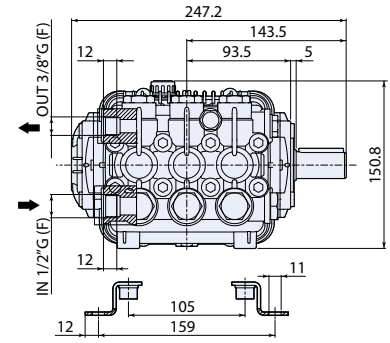

2988501

N version

MOD	COD	l/min	gpm	bar	psi	hp	kW	N° giri/1'	kg
RW 1450rpm Nversion Ø24mm									
RW 15.15 N	22584	15	3,96	150	2200	5,5	4	1450	14
● RW 15.20 H N	22585	15	3,96	200	2900	7,5	5,5	1450	14,5
RW 18.17 N	22586	18	4,75	170	2500	7,5	5,5	1450	14
● RW 18.20 H N	22587	18	4,75	200	2900	10	7,5	1450	14,5
● RW 21.15 H N	22588	21	5,55	150	2200	7,5	5,5	1450	14
● RW 21.20 H N	22589	21	5,55	200	2900	10	7,5	1450	14,5
RWA 1750rpm Nversion Ø24mm									
RWA 4G22 N	22990	15,1	4	150	2200	5,5	4	1750	14
● RWA 4G30 H N	22991	15,1	4	205	3000	7,5	5,5	1750	14,5
● RWA 5.5G22 H N	22992	20,8	5,5	150	2200	7,5	5,5	1750	14,5
● RWA 5.5G30 H N	22993	20,8	5,5	205	3000	10	7,5	1750	14,5

- testa nichelata**
nickel plated brass head
- testa in ottone**
brass head
- bielle in alluminio**
aluminium connecting-rods



298 Series

ELECTRIC MOTOR-PUMP UNITS

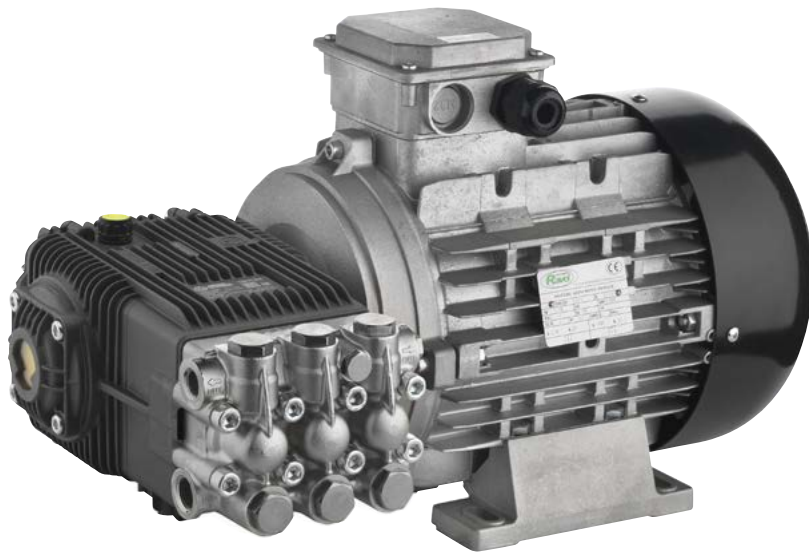

- 
lavaggio industriale
industrial cleaning
- 
idropultrici
pressure washers
- 
processi industriali
industrial processes
- 
autolavaggio
car wash
- 
produzione
manufacturing
- 
agricoltura
agriculture
- 
municipality
- 
misting
- 
pulizia tubazioni
sewer jetting
- 
cantieri ed edilizia
construction industry
- 
antincendio
fire fighting

GR. 112 motor hollow shaft

GR. 112 motor hollow shaft

GR. 132 S motor hollow shaft

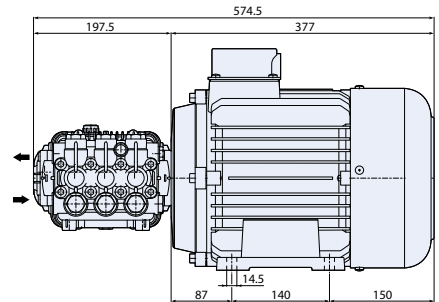
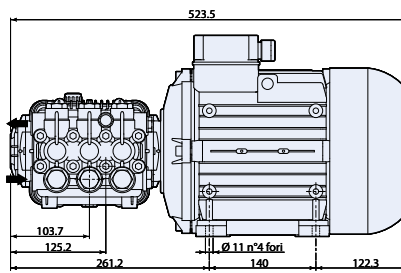
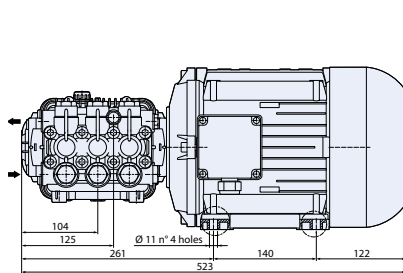

2988529

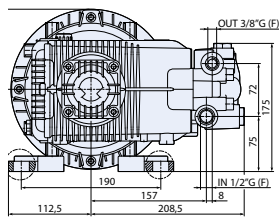



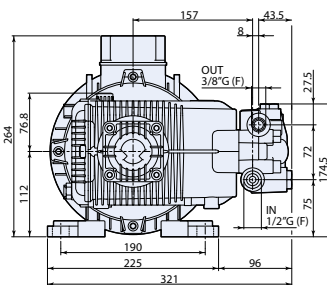

2988508

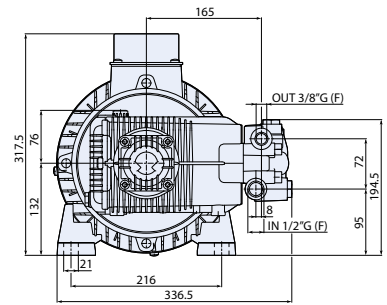

2988515



MOD	COD	 MAX	 MAX		KG NET						
	3 ~	l/min	gpm	bar	psi	hp	kW	N° giri/1'	V 3-50Hz	Gr.	kg
HRW 1450rpm											
HRW 15.15 ET	23974	15	3,96	150	2200	5,5	4	1450	230/400	112	30
● HRW 15.20 H ET	23975	15	3,96	200	2900	7,5	5,5	1450	230/400	112	40
● HRW 21.15 H ET	23976	21	5,50	150	2200	7,5	5,5	1450	230/400	112	40
● HRW 21.20 H ET	23977	21	5,50	200	2900	10	7,5	1450	230/400	132 S	50

- 
testa nichelata
nickel plated brass head
- 
testa in ottone
brass head
- 
bielle in alluminio
aluminium connecting-rods
- 
frequenza motore
motor frequency



**194
SERIES**

194 SERIES

XWF
XW
XWL
XWT
XWA
XWLA
XWP
SXW

SXWA
SHP
SHPA
STP-I
STPA-I
CWX
WHW
WHWL

HXW
HXWL
HXWA
HSXW
HSHP
HYD-XW
HYD-XWL
XW+F38

XW+F60
XWL+F60
XWP+F60
SXW+F60
XW+F62
XWL+F62
XWP+F62
SHP+F62



Corpo in alluminio pressofuso con scritta "Made in Italy" per sottolineare la qualità italiana di sempre, logo AR in rilievo e targa dati stampata col laser.

Coperchi in alluminio pressofuso

Coperchio laterale con livello olio.
Coperchio posteriore con scarico olio.

Bielle in lega zinco-alluminio pressofuso o in bronzo.

Testa in ottone stampato. Possibilità di testa in ottone nichelato.
Testa in AISI 420 per le versioni STP-I, STPA-I.

Pistoni in ceramica.

Crankcase in pressure die-cast aluminium alloy with impressed "Made in Italy" to emphasize the Italian quality as always, embossed trademark and data plate laser printed.

Cover in pressure die-cast aluminium alloy

Side cover incorporated with oil sight glass. Back cover incorporated with oil drain outlet.

Connecting rods in die-cast zinc-aluminium alloy. Bronze connecting rods available.

Pump head in forged brass. Pump head in nickel-plated brass available.

Pump head in AISI 420 for STP-I and STPA-I models.

Ceramic plungers.

194 Series

POMPA ALBERO MASCHIO Solid shaft pump



lavaggio industriale
industrial cleaning



processi industriali
industrial processes



autolavaggio
car wash



produzione
manufacturing



agricoltura
agriculture



municipality



misting



pulizia tubazioni
sewer jetting



cantieri ed edilizia
construction industry



antincendio
fire fighting

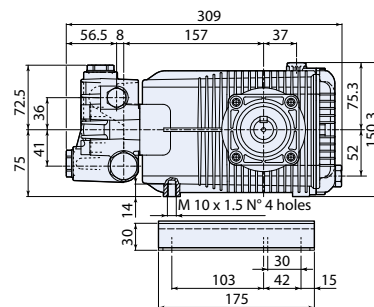

Piedi a richiesta.
Base on request.

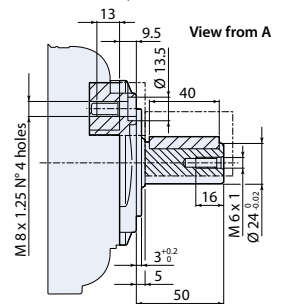
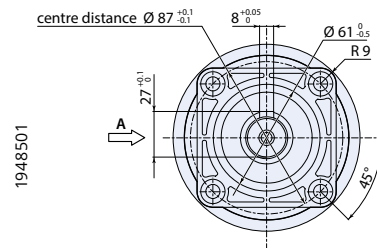
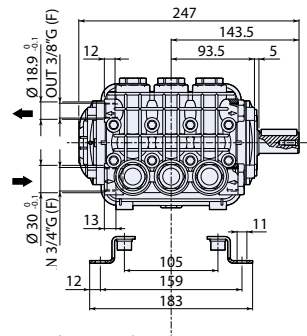

N version

MOD	COD	MAX		MAX				KG NET
		l/min	gpm	bar	psi	hp	kW	N° giri/1'
XWF 1000rpm Nversion Ø24mm								
XWF 26.06 N	21049	26	6,87	60	900	4	3	1000
XWF 26.09 N	21050	26	6,87	90	1300	5,5	4	1000
XWF 26.12 N	21051	26	6,87	120	1740	7,5	5,5	1000
XWF 26.15 N	21052	26	6,87	150	2200	10	7,5	1000
XWF 26.20 N	21053	26	6,87	200	2900	13	9,6	1000
XWF 30.10 N	21054	30	7,92	100	1450	7,5	5,5	1000
XWF 30.18 N	21055	30	7,92	180	2600	15	11	1000
XWF 30.20 N	22921	30	7,92	200	2900	15	11	1000
XWF 36.17 N	21056	36	9,51	170	2500	15	11	1000



testa in ottone
brass head



bielle in bronzo
bronze connecting-rods



bielle in alluminio
aluminium connecting-rods



194 Series

POMPA ALBERO MASCHIO Solid shaft pump



lavaggio industriale
industrial cleaning

idropultrici
pressure washers

processi industriali
industrial processes

autolavaggio
car wash

produzione
manufacturing



agricoltura
agriculture



municipality



misting



pulizia tubazioni
sewer jetting



cantieri ed edilizia
construction industry



antincendio
fire fighting

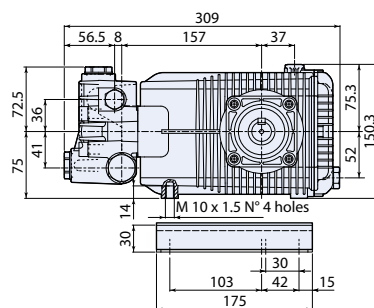

Piedi a richiesta.
Base on request.

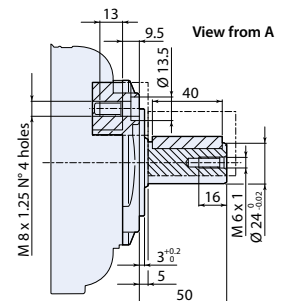
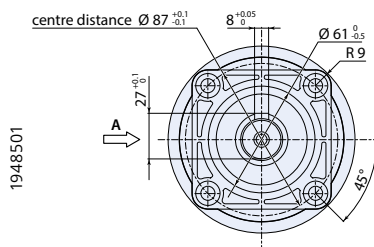
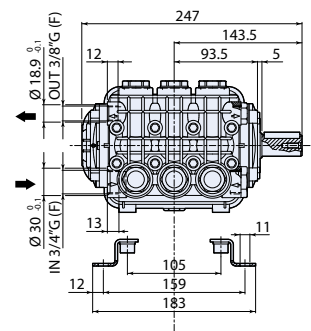

N version

MOD	COD	MAX	MAX	MAX	MAX	hp	kW	N° giri/1'	NET
		l/min	gpm	bar	psi	hp	kW	N° giri/1'	kg
XW 1450 rpm Nversion Ø24mm									
XW 15.15 N	20352	15	3,96	150	2200	5,5	4	1450	16
XW 15.20 N	20353	15	3,96	200	2900	7,5	5,5	1450	16
XW 15.30 N	20592	15	3,96	300	4351	12	8,7	1450	16
XW 21.20 N	20174	21	5,55	200	2900	10	7,5	1450	16
XW 21.25 N	20058	21	5,55	250	3625	12,5	9,2	1450	16
XW 21.28 N	21136	21	5,55	280	4060	15	11	1450	16
XW 26.12 N	20175	26	6,87	120	1740	7,5	5,5	1450	16
XW 26.15 N	20176	26	6,87	150	2200	10	7,5	1450	16
XW 26.20 N	20059	26	6,87	200	2900	12,5	9,2	1450	16
XW 26.23 N	20177	26	6,87	230	3400	15	11	1450	16
XW 30.10 N	20178	30	7,92	100	1450	7,5	5,5	1450	16
XW 30.15 N	20179	30	7,92	150	2200	10	7,5	1450	16
XW 30.20 N	20060	30	7,92	200	2900	15	10	1450	16
XW 30.25 N	21137	30	7,92	250	3625	19	14	1450	16

A richiesta testa nichelata · Nickel plated head available.



testa in ottone
brass head



bielle in alluminio
aluminium connecting-rods

194 Series

POMPA ALBERO MASCHIO Solid shaft pump



lavaggio industriale
industrial cleaning



idropulitrici
pressure washers



processi industriali
industrial processes



autolavaggio
car wash



produzione
manufacturing



agricoltura
agriculture



municipality



misting



pulizia tubazioni
sewer jetting



cantieri ed edilizia
construction industry



antincendio
fire fighting

ATEX

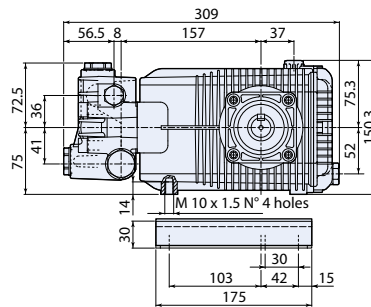

Piedi a richiesta.
Base on request.

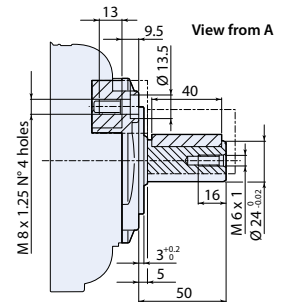
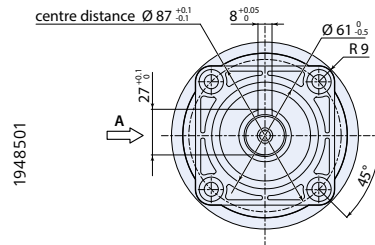
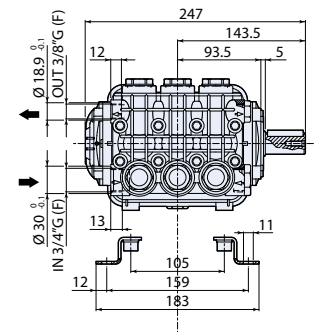

N version

MOD	COD	MAX	MAX	MAX	MAX	MAX	MAX	MAX	NET
		l/min	gpm	bar	psi	hp	kW	N° giri/1'	kg
XW 1450 rpm Nversion Ø24mm									
XW 15.15 N	28367	15	3,96	150	2200	5,5	4	1450	16
XW 15.20 N	28368	15	3,96	200	2900	7,5	5,5	1450	16
XW 15.30 N	28369	15	3,96	300	4351	12	8,7	1450	16
XW 21.20 N	28370	21	5,55	200	2900	10	7,5	1450	16
XW 21.25 N	28371	21	5,55	250	3625	12,5	9,2	1450	16
XW 21.28 N	28372	21	5,55	280	4060	15	11	1450	16
XW 26.12 N	28373	26	6,87	120	1740	7,5	5,5	1450	16
XW 26.15 N	28374	26	6,87	150	2200	10	7,5	1450	16
XW 26.20 N	28375	26	6,87	200	2900	12,5	9,2	1450	16
XW 26.23 N	28376	26	6,87	230	3400	15	11	1450	16
XW 30.10 N	28377	30	7,92	100	1450	7,5	5,5	1450	16
XW 30.15 N	28378	30	7,92	150	2200	10	7,5	1450	16
XW 30.20 N	28379	30	7,92	200	2900	15	10	1450	16

A richiesta testa nichelata · Nickel plated head available.



testa in ottone
brass head



bielle in alluminio
aluminium connecting-rods



certificata
certificated



194 Series

POMPA ALBERO MASCHIO Solid shaft pump



for
XWL



for
XWT

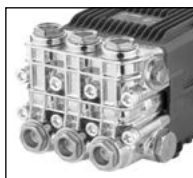

● Model H

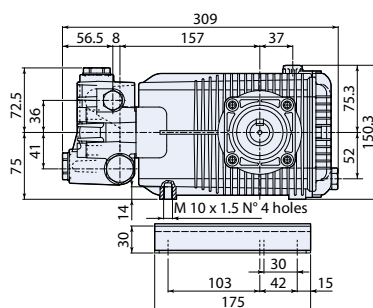

Piedi a richiesta.
Base on request.

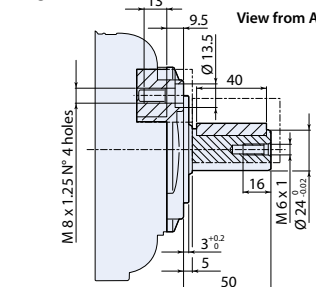
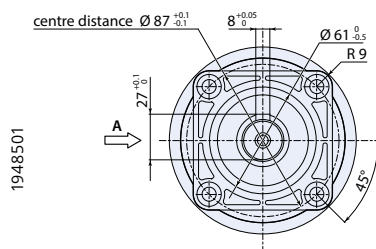
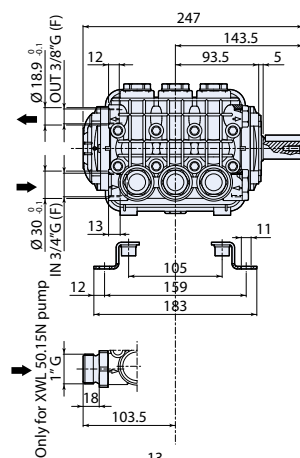

N version

MOD	COD									
		l/min	gpm	bar	psi	hp	kW	N° giri/1'	kg	
XWL 1450rpm Nversion Ø24mm										
XWL 36.15 N	22175	36	9,51	150	2200	15	11	1450	16	
XWL 41.20 N	22462	41	10,83	200	2900	20	15	1450	16	
XWL 42.05 N	21057	42	11,09	50	725	5,5	4	1450	16	
XWL 42.07 N	21058	42	11,09	70	1000	8	5,9	1450	16	
XWL 42.10 N	21059	42	11,09	100	1450	11	8,2	1450	16	
XWL 42.15 N	21060	42	11,09	150	2200	16	11,8	1450	16	
XWL 50.15 N*	23709	50	13,2	150	2200	20	15	1450	16	
● XWL 50.15 H N*	23816	50	13,2	150	2200	20	15	1450	16	
XWT 550rpm Nversion Ø24mm										
XWT 21.18 N	21048	21	5,55	180	2600	10	7,5	550	16	
XWT 21.20 N	22994	21	5,55	200	2900	15	11	550	16	



* Minimo +0,1 bar (+1,5 psi) di pressione in entrata. • Min. +0,1 bar (+1,5 psi) inlet pressure.

194 Series

POMPA ALBERO MASCHIO Solid shaft pump



lavaggio industriale
industrial cleaning



processi industriali
industrial processes



autolavaggio
car wash



produzione
manufacturing



agricoltura
agriculture



municipality



misting



pulizia tubazioni
sewer jetting



cantieri ed edilizia
construction industry

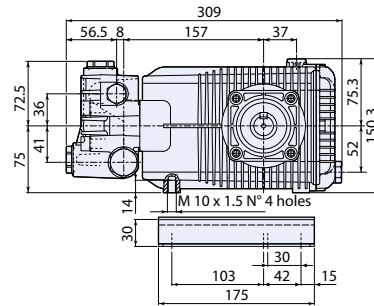

Piedi a richiesta.
Base on request.

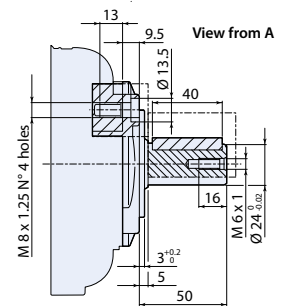
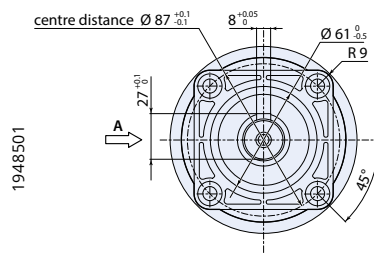
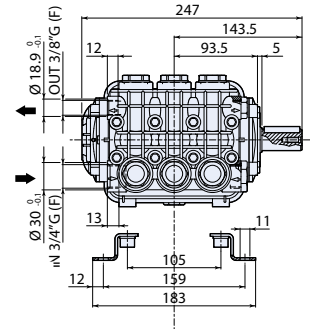

N version

MOD	COD	MAX	MAX						
		l/min	gpm	bar	psi	hp	kW	N° giri/1'	kg

XWA 1750rpm Nversion Ø24mm									
XWA 4G20 N	20781	15,1	4	140	2000	5,5	4	1750	16
XWA 4G30 N	20354	15,1	4	205	3000	7,5	5,5	1750	16
XWA 5.5G22 N	20180	20,8	5,5	150	2200	7,5	5,5	1750	16
XWA 5.5G30 N	20061	20,8	5,5	205	3000	10	7,5	1750	16
XWA 5.5G40 N	21138	20,8	5,5	275	4000	14	10,5	1750	16
XWA 7G22 N	20181	26,5	7	150	2200	10	7,5	1750	16
XWA 7G32 N	20062	26,5	7	220	3200	14	10,5	1750	16
XWA 7G35 N	21139	26,5	7	240	3500	15	11	1750	16
XWA 7G40 N	21140	26,5	7	275	4000	17	12,5	1750	16
XWA 8G19 N	20182	30,2	8	130	1900	10	7,5	1750	16
XWA 8G29 N	20063	30,2	8	200	2900	15	11	1750	16
XWA 8G35 N	21141	30,2	8	240	3500	18	13,4	1750	16
XWA 9G16 N	20183	34	9	110	1600	10	7,5	1750	16
XWA 9G24 N	20064	34	9	165	2400	15	11	1750	16
XWA 9G30 N	21645	34	9	205	3000	18	13,4	1750	16

XWLA 1750rpm Nversion Ø24mm									
XWLA 13G15 N*	21198	49,2	13	100	1450	13	9,6	1750	16



testa in ottone
brass head



bielle in alluminio
aluminium connecting-rods

* Minimo +0,1 bar (+1,5 psi) di pressione in entrata. • Min. +0,1 bar (+1,5 psi) inlet pressure.



194 Series

POMPA ALBERO MASCHIO Solid shaft pump



lavaggio industriale
industrial cleaning



processi industriali
industrial processes



autolavaggio
car wash



produzione
manufacturing



agricoltura
agriculture



municipality



misting



pulizia tubazioni
sewer jetting



cantieri ed edilizia
construction industry

ATEX

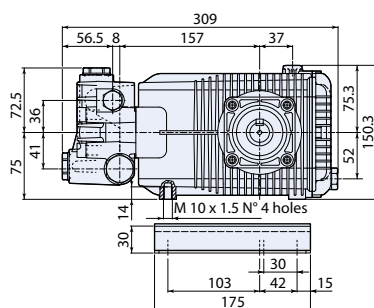

Piedi a richiesta.
Base on request.

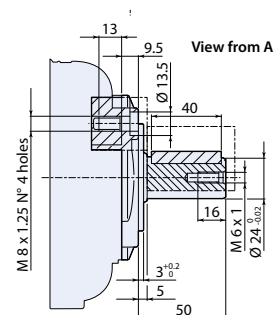
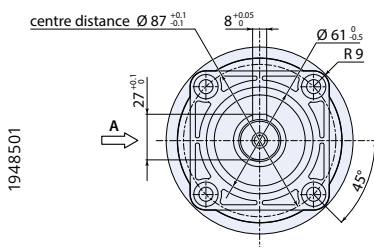
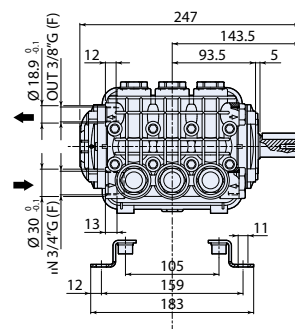

N version

MOD	COD	MAX	MAX	MAX	MAX	MAX	MAX	MAX	NET
		l/min	gpm	bar	psi	hp	kW	N° giri/1'	kg
XWA 1750rpm Nversion Ø24mm									
XWA 4G20 N	28380	15,1	4	140	2000	5,5	4	1750	16
XWA 4G30 N	28381	15,1	4	205	3000	7,5	5,5	1750	16
XWA 5.5G22 N	28382	20,8	5,5	150	2200	7,5	5,5	1750	16
XWA 5.5G30 N	28383	20,8	5,5	205	3000	10	7,5	1750	16
XWA 5.5G40 N	28384	20,8	5,5	275	4000	14	10,5	1750	16
XWA 7G22 N	28385	26,5	7	150	2200	10	7,5	1750	16
XWA 7G32 N	28386	26,5	7	220	3200	14	10,5	1750	16
XWA 7G35 N	28387	26,5	7	240	3500	15	11	1750	16
XWA 8G19 N	28389	30,2	8	130	1900	10	7,5	1750	16
XWA 8G29 N	28390	30,2	8	200	2900	15	11	1750	16
XWA 9G16 N	28391	34	9	110	1600	10	7,5	1750	16
XWA 9G24 N	28392	34	9	165	2400	15	11	1750	16



testa in ottone
brass head



bielle in alluminio
aluminium connecting-rods



certificata
certificated

194 Series

POMPA ALBERO MASCHIO Solid shaft pump



lavaggio industriale
industrial cleaning
processi industriali
industrial processes
autolavaggio
car wash
produzione
manufacturing
agricoltura
agriculture



municipality
misting
pulizia tubazioni
sewer jetting
cantieri ed edilizia
construction industry

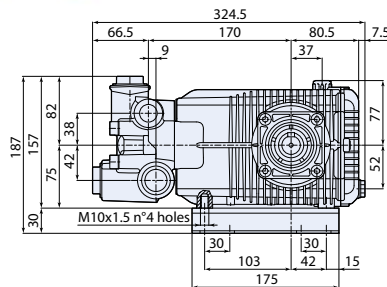

Piedi a richiesta.
Base on request.

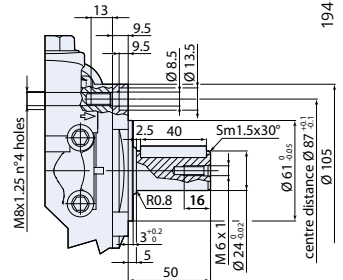
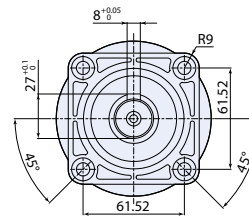
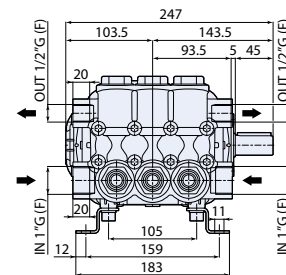
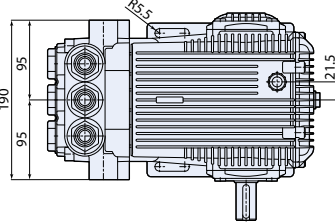

1948558

Parte meccanica della XW con pistoni maggiorati, nuovo design della testata con tenute e valvole che permettono di raggiungere portate maggiori.

Pump that maintains the drive of the XW. Larger-size plungers, new pump head design with seals and valves that enable to achieve higher flow rates (superior to 50 l/min).

N version

MOD	COD	MAX	MAX	MAX				
		l/min	gpm	bar	psi	hp	kW	N° giri/1'
XWP 1450rpm Nversion Ø24mm								
XWP 50.15 N	26283	50	13,2	150	2200	20	15	1450
XWP 50.20 N	29095	50	13,2	200	2900	27	20	1450
XWP 55.14 N	26284	55	14,5	140	2000	20	15	1450
XWP 55.20 N	29096	55	14,5	200	2900	29	21,5	1450
XWP 60.13 N	26285	60	15,9	130	1900	20	15	1450
XWP 60.20 N	29170	60	15,9	200	2900	31	23	1450
XWP 65.12 N	26286	65	17,2	120	1740	20	15	1450
XWP 70.15 N	26919	70	18,5	150	2200	27	20	1450
XWP 70.18 N	29768	70	18,5	180	2600	32	24	1450

A richiesta testa nichelata · Nickel plated head available.



testa in ottone
brass head



bielle in alluminio
aluminium connecting-rods



bielle in bronzo
bronze connecting-rods



194 Series

POMPA ALBERO MASCHIO Solid shaft pump



lavaggio industriale
industrial cleaning



idropulitrici
pressure washers



processi industriali
industrial processes



agricoltura
agriculture



municipality



pulizia tubazioni
sewer jetting



cantieri ed edilizia
construction industry



antincendio
fire fighting

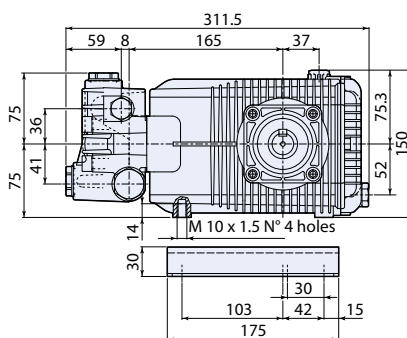

Piedi a richiesta.
Base on request.

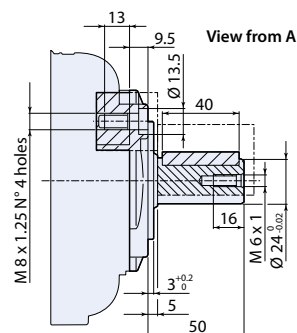
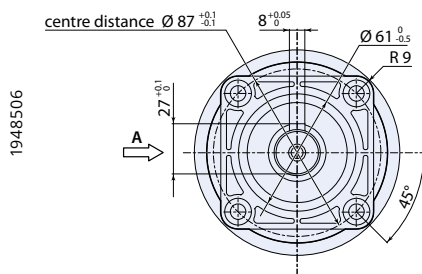
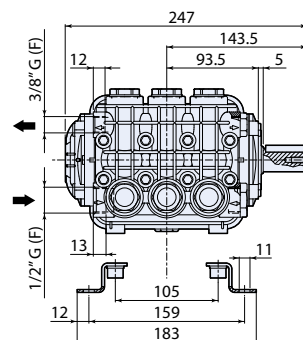

N version

MOD	COD	MAX		MAX				KG NET
		l/min	gpm	bar	psi	hp	kW	N° giri/1'
SXW 1450rpm Nversion Ø24mm								
SXW 15.35 N	20807	15	3,96	350	5100	15	11	1450
SXW 17.35 N	23208	17	4,5	350	5100	17	12,7	1450
SXW 19.30 N	22899	19	5	300	4351	15	11	1450
SXW 21.28 N	20930	21	5,55	280	4060	20	15	1450
SXW 21.35 N	20808	21	5,55	350	5100	24	18	1450
SXWA 1750rpm Nversion Ø24mm								
SXWA 4G50 N	21024	15,1	4	345	5000	13	9,5	1750
SXWA 5.5G50 N	21006	20,8	5,5	345	5000	18	13,4	1750
SXWA 7G50 N	21211	26,5	7	345	5000	22	16,2	1750



testa in ottone
brass head



bielle in alluminio
aluminium connecting-rods

194 Series

POMPA ALBERO MASCHIO Solid shaft pump



lavaggio industriale
industrial cleaning



idropultrici
pressure washers



processi industriali
industrial processes



agricoltura
agriculture



pulizia tubazioni
sewer jetting



cantieri ed edilizia
construction industry



antincendio
fire fighting

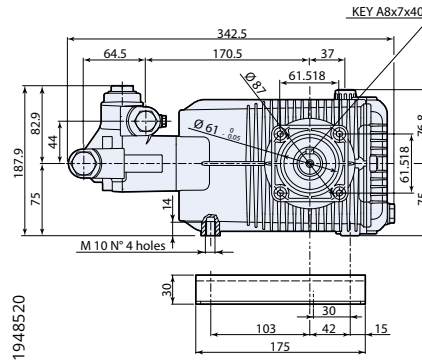

1948520

Piedi a richiesta.
Base on request.

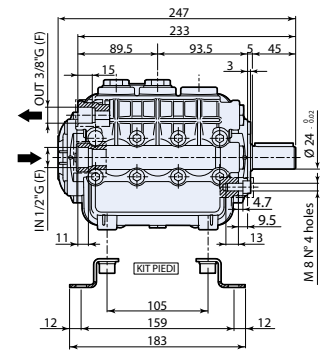

N version

MOD	COD	MAX		MAX				KG NET
		l/min	gpm	bar	psi	hp	kW	N° giri/1'
SHP 1450rpm Nversion Ø24mm								
SHP 10.50 N	22569	10	2,64	500	7250	14	10,4	1450
SHP 15.50 N	21825	15	3,96	500	7250	20	15	1450
SHP 20.50 N	25413	20	5,30	500	7250	25	18,5	1450
SHP 22.50 N	21826	22	5,80	500	7250	27	20	1450
SHPA 1750rpm Nversion Ø24mm								
SHPA 4G70 N	23022	15,1	4	500	7250	20	15	1750



testa in ottone
brass head



bielle in alluminio
aluminium connecting-rods

STP-I
STPA-I

194 SERIES

STP-I Stainless Steel ad alta pressione
fino a 500 bar.

- Albero in acciaio ad alta resistenza e supportato da due **cuscinetti a rulli conici** di alta qualità e sovradimensionati.
- Bielle in speciale **lega zinco-alluminio antifrizione.**
- Corpo pompa e coperchi laterali in lega di **alluminio ad alta resistenza** per pressofusione e con trattamento di **anodizzazione.**
- Pistoni in **ceramica** integrale.
- Sistema di tenuta a **doppia guarnizione.**
- Testa in **acciaio inox** AISI 420.
- **Valvole di costruzione robusta** per reggere le alte pressioni di utilizzo.
- Coperchio posteriore con **scarico** e **livello olio**
- **Livello olio laterale.**
- Corpo pompa con scritta "**Made in Italy**" per sottolineare la qualità italiana di sempre, **logo AR in rilievo** e **targa dati stampata col laser.**

STP-I Stainless Steel pump up to 500 bar.

- *Shaft in high-strength steel supported by two **high-quality, oversized tapered roller bearings.***
- *Connecting rods in a special **low-friction zinc-aluminium alloy.***
- *Pump head in **stainless steel** AISI 420.*
- *Body and side covers in **anodised die-cast high-strength aluminium alloy.***
- ***Ceramic plungers.***
- ***Double gasket sealing system.***
- ***Valves** are of **rugged construction** to withstand the high operating pressures.*
- *Back cover incorporated with **oil sight glass** and **oil drain outlet.***
- ***Lateral oil sight glass.***
- *Body with impressed "**Made in Italy**" to emphasize the italian quality as always, **embossed trademark** and **data plate laser printed.***

**AISI
420**





194 Series

POMPA ALBERO MASCHIO Solid shaft pump



autolavaggio
car wash

CAR WASH

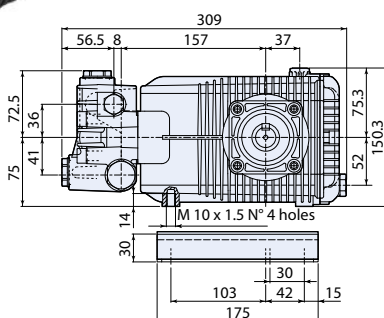

Piedi a richiesta.
Base on request.

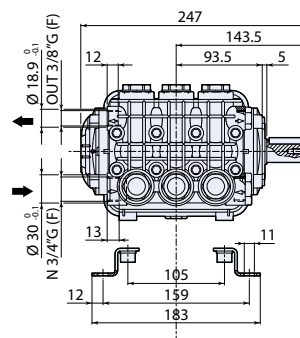

1948501

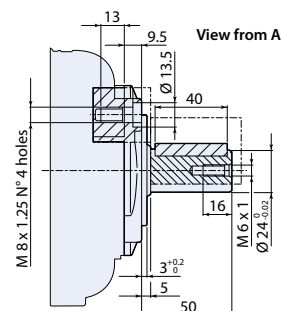
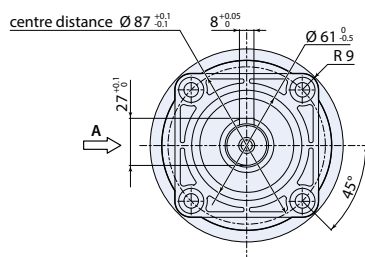

N version

MOD	COD	MAX	MAX						
		l/min	gpm	bar	psi	hp	kW	N° giri/1'	kg
CWX 950rpm Nversion Ø24mm									
CWX 15.17 N	20472	15	3,96	170	2500	7,5	5,2	950	16
CWX 1200rpm Nversion Ø24mm									
CWX 18.10 N	20473	18	4,75	100	1450	5,5	3,6	1200	16
CWX 1750rpm Nversion Ø24mm									
CWX 15.17 N	20474	15	3,96	170	2500	7,5	5,2	1750	16



testa
nichelata
nickel plated
brass head



bielle in
alluminio
aluminium
connecting-rods

194 Series

POMPA ALBERO MASCHIO
Solid shaft pump



autolavaggio municipality
car wash



HOT WATER 85°C

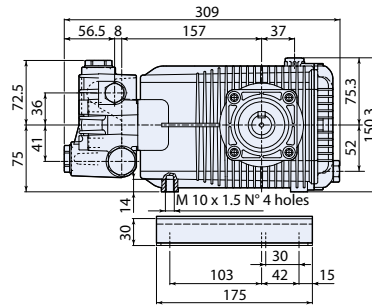

Piedi a richiesta.
Base on request.

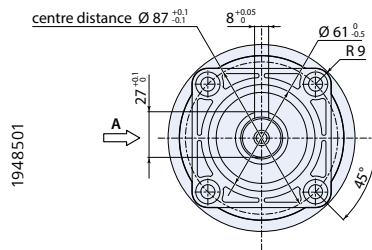

1948501

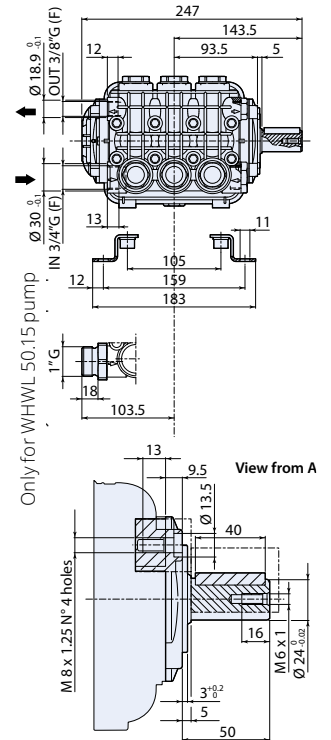

Only for WHWL 50:15 pump

View from A

N version

MOD	COD	MAX	MAX						
		l/min	gpm	bar	psi	hp	kW	N° giri/1'	kg
WHW 1450rpm		Nversion Ø24mm							
WHW 15.20 N	22986	15	3,96	200	2900	7,5	5,5	1450	16
WHW 21.15 N	22987	21	5,55	150	2200	7,5	5,5	1450	16
WHW 26.15 N	22988	26	6,87	150	2200	10	7,5	1450	16
WHW 32.20 N	22989	32	8,45	200	2900	15	11	1450	16
WHWL 1450rpm		Nversion Ø24mm							
WHWL 38.15 N	23966	38	10	150	2200	15	11	1450	16,5
WHWL 42.15 N	23967	42	11,09	150	2200	16	11,8	1450	16,5
WHWL 50.15 N	23968	50	13,2	150	2200	20	15	1450	16,5



testa
nichelata
nickel plated
brass head



MAX
85°



PTFE
guarnizioni
in PTFE
PTFE gasket
sealing



bielle in
alluminio
aluminium
connecting-rod



194 Series

ELECTRIC MOTOR-PUMP UNITS

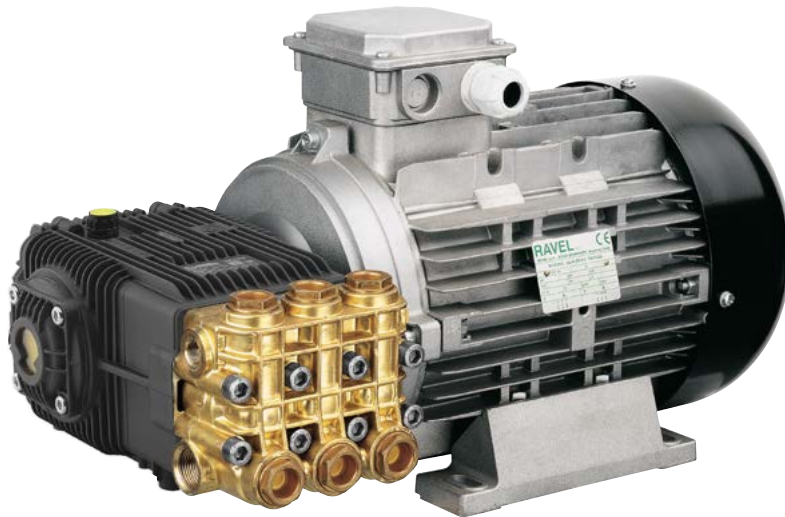

GR. 100 motor hollow shaft

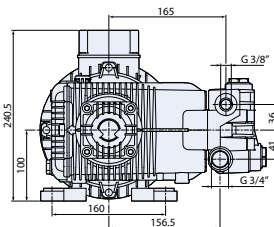
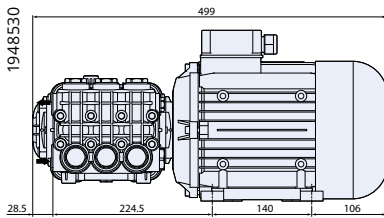

GR. 112 motor hollow shaft

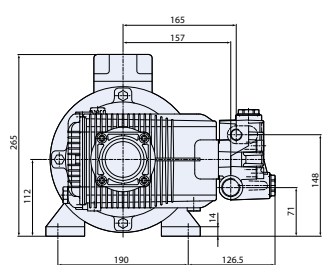
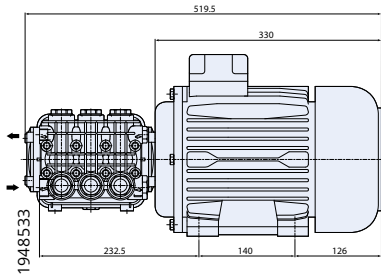

GR. 132 S motor hollow shaft

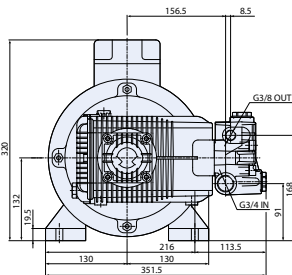
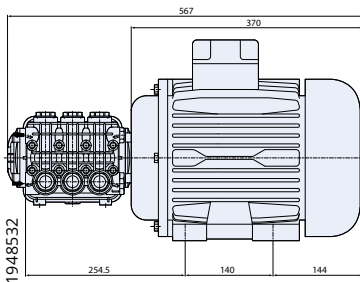

GR. 132 L motor hollow shaft

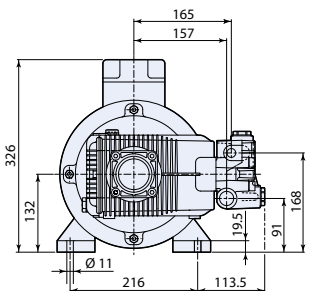
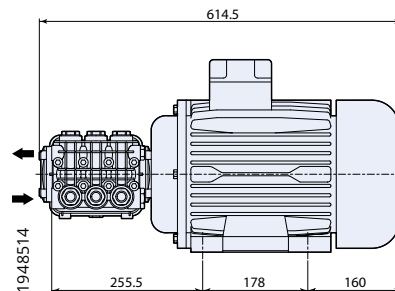

COD	3 ~	l/min	gpm	bar	psi	hp	kW	N° giri/1'	V 3-50Hz	Gr.	kg
HXW 1450 rpm											
HXW 15.15 ET	20871	15	3,96	150	2200	5,5	4	1450	230/400	100	33
HXW 15.20 ET	20872	15	3,96	200	2900	7,5	5,5	1450	230/400	112	39
HXW 21.20 ET	20224	21	5,55	200	2900	10	7,5	1450	230/400	132 S	63
HXW 26.15 ET	20225	26	6,87	150	2200	10	7,5	1450	230/400	132 S	63
HXW 30.10 ET	20227	30	7,92	100	1450	7,5	5,5	1450	230/400	112	39
HXW 30.15 ET	20228	30	7,92	150	2200	10	7,5	1450	230/400	132 S	63
HXW 30.20 ET	20229	30	7,92	200	2900	15	11	1450	230/400	132 L	70



194 Series

ELECTRIC MOTOR-PUMP UNITS

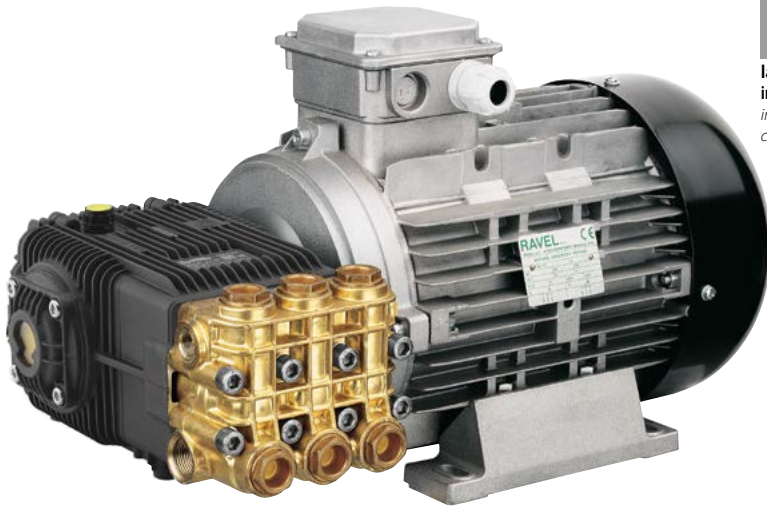

-  **lavaggio industriale**
industrial cleaning
-  **idropultrici**
pressure washers
-  **processi industriali**
industrial processes
-  **autolavaggio**
car wash
-  **produzione**
manufacturing
-  **agricoltura**
agriculture
-  **municipality**
-  **misting**
-  **pulizia tubazioni**
sewer jetting
-  **cantieri ed edilizia**
construction industry

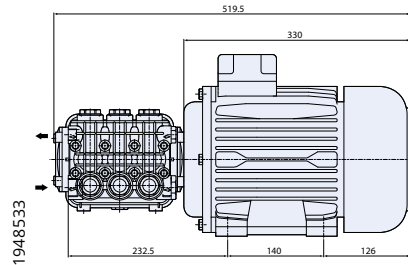



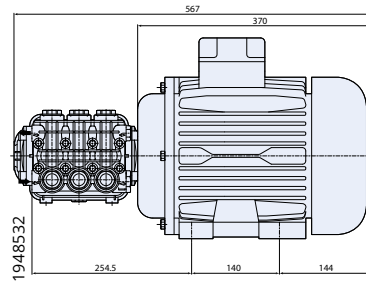
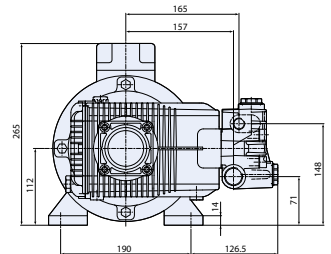

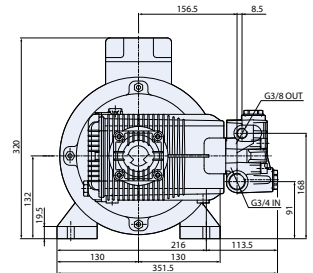

GR. 112 motor hollow shaft



GR. 132 S motor hollow shaft



COD	3 ~	 MAX l/min	 MAX gpm	 MAX bar	 MAX psi	hp	kW	 N° giri/1'	V	Gr.	 NET kg
HXL 1450rpm											
HXL 42.07 ET	21183	42	11,09	70	1000	7,5	5,5	1450	230/400 ^c	112	39
HXL 42.10 ET	21184	42	11,09	100	1450	10	7,5	1450	230/400 ^c	132 S	63
HXA 1750rpm											
HXA 4G20 ET	20782	15,1	4	140	2000	5,5	4	1750	230/400 ^d	112	33
HXA 4G30 ET	20783	15,1	4	205	3000	7,5	5,5	1750	230/400 ^d	112	39



testa in ottone
brass head



bielle in alluminio
aluminium connecting-rods



frequenza motore
motor frequency

c) 3~ 50 Hz • d) 3~ 60 Hz



194 Series

ELECTRIC MOTOR-PUMP UNITS



lavaggio industriale
industrial cleaning



idropultrici
pressure washers



processi industriali
industrial processes



agricoltura
agriculture



municipality
municipality



pulizia tubazioni
sewer jetting



cantieri ed edilizia
construction industry

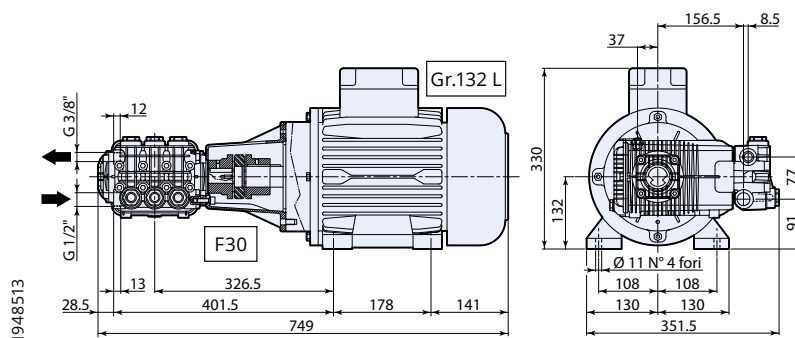

Flangiatura con giunto elastico.
Bell housing + flexible coupling.

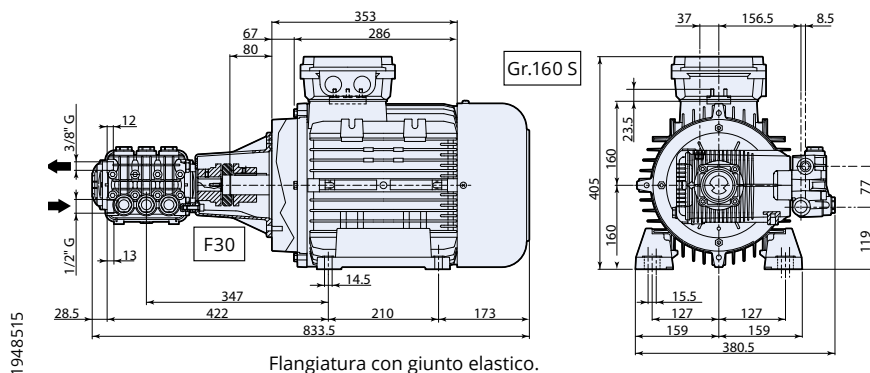

Flangiatura con giunto elastico.
Bell housing + flexible coupling.

COD	3 ~		MAX		MAX		N° giri/1'		V 3-50Hz	Gr.	KG NET
	l/min	gpm	bar	psi	hp	kW					
HSXW 1450rpm											
HSXW 15.35 ET 21066	15	4	350	5100	15	11	1450	230/400	132 L	75	
HSXW 21.35 ET 22995	21	5,55	350	5100	20	15	1450	400/690	160 S	115	



testa in ottone
brass head



bielle in alluminio
aluminium connecting-rods



frequenza motore
motor frequency

194 Series

ELECTRIC MOTOR-PUMP UNITS

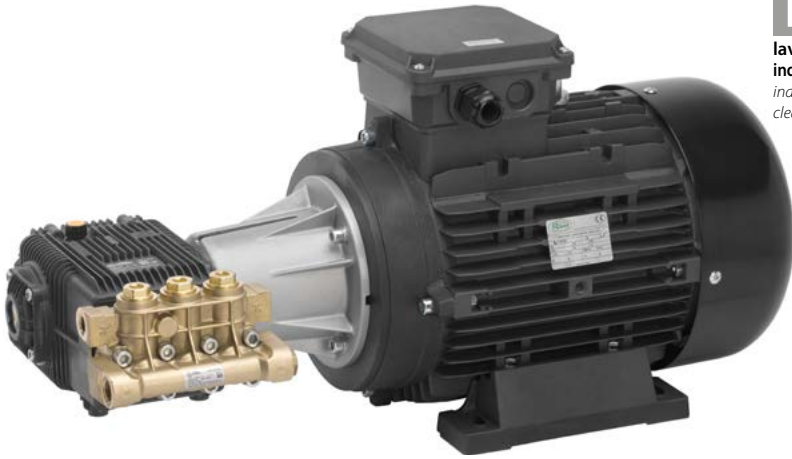

lavaggio industriale
industrial cleaning



idropultrici
pressure washers



processi industriali
industrial processes



agricoltura
agriculture



pulizia tubazioni
sewer jetting



cantieri ed edilizia
construction industry

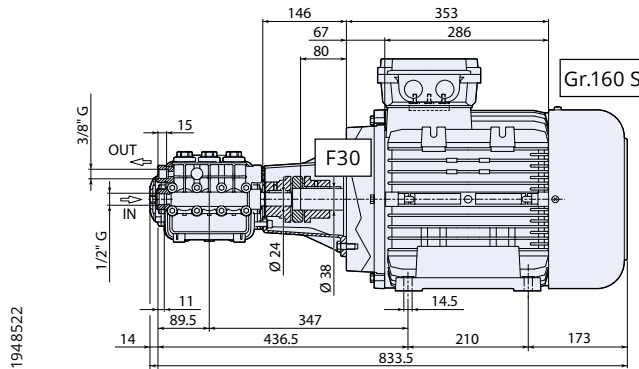

Flangiatura con giunto elastico.
Bell housing + flexible coupling.

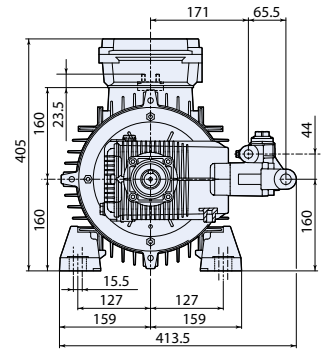

COD	MAX		MAX				N° giri/1'		V 3-50Hz		Gr.	kg NET
	3 ~	l/min	gpm	bar	psi	hp	kW					
HSHP 1450rpm												
HSHP 15.50 ET	22082	15	3,96	500	7250	20	15	1450	400/690	160 S	115	
HSHP 20.50 ET	25414	20	5,30	500	7250	25	18,5	1450	400/690	160 S	115	



testa in ottone
brass head



bielle in alluminio
aluminium connecting-rods



3~50Hz
frequenza motore
motor frequency



194 Series

GASOLINE MOTOR-PUMP UNITS



idropultrici
pressure
washers



processi industriali
industrial
processes



autolavaggio
car wash



agricoltura
agriculture



municipality



cantieri ed edilizia
construction
industry

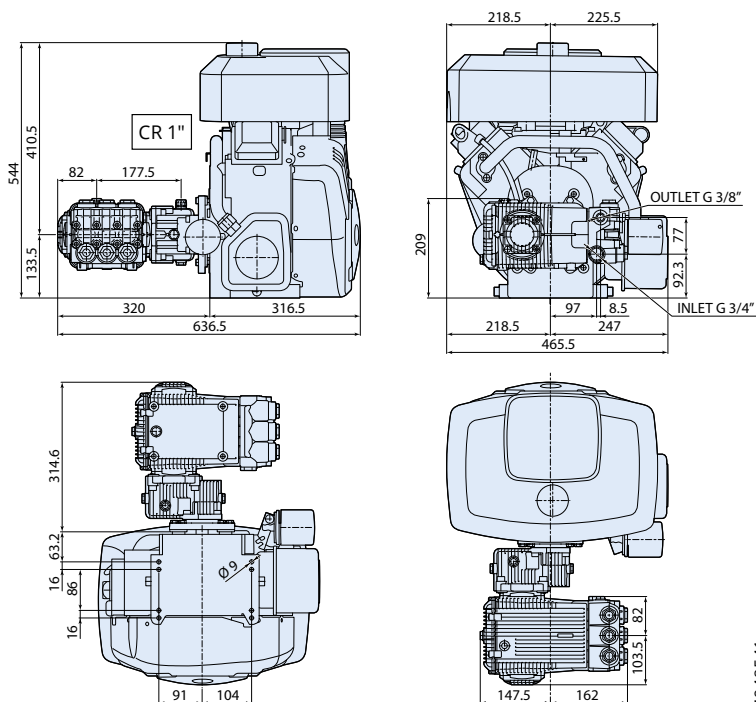
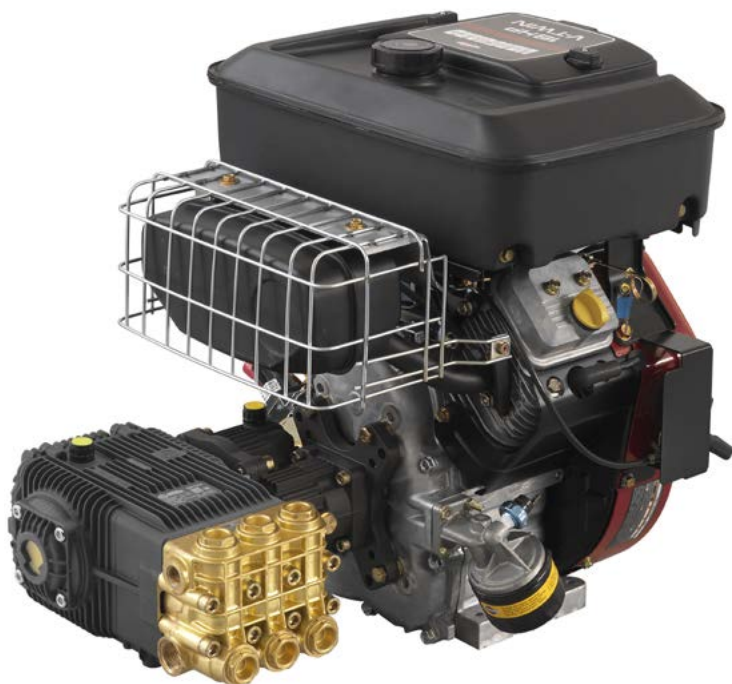

1948541

MOD	COD	MAX	MAX	RPM	NET		
		l/min	gpm	bar	psi	N° giri/1' pompa	kg
XW Gearbox Drive							
XW 30.15 CR B&S VANGUARD	18 20241	30	7.92	150	2200	1450	53



testa in ottone
brass
head



bielle in alluminio
aluminium
connecting-rods



motore a scoppio
gasoline
engine

194 Series

HYDRAULIC DRIVE

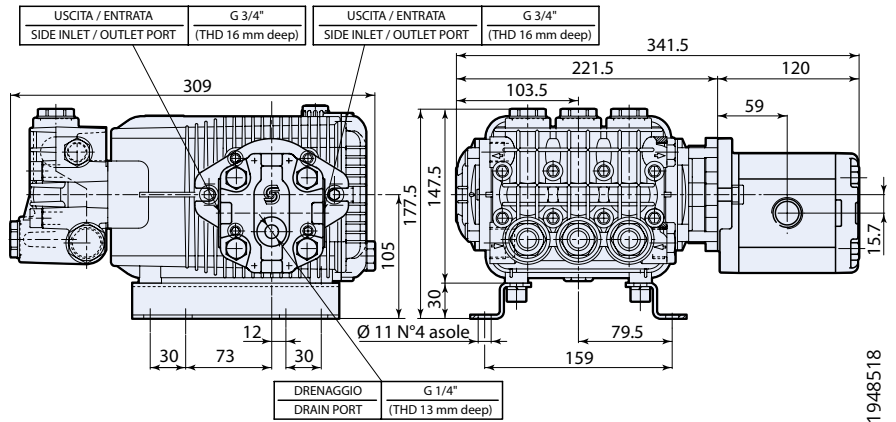

1948518



HYD - XW • HYD - XL

MOD	COD	POMPA A PISTONI • HP PISTON PUMP						MOTORE IDRAULICO • HYDRAULIC MOTOR						KG NET		
		l/min gpm		bar psi		N° giri/1' hp		SAUER DANFOSS (*)		l/min gpm		N° giri/1' hp				
		MAX	MAX	MAX	MAX	RPM	RPM	Type	Cod	cm ³	bar	MAX	MAX	RPM	RPM	kg
HYD-XW																
HYD-XW 30.10	21606	30	7,92	100	1450	1450	7,5	SNM2NN/022 BN06GAM1F5F5N	4770	22,8	125**	36**	1450	19,2		
HYD-XW 30.15	22694	30	7,92	150	2200	1450	12	SNM2NN/022 BN06GAM1F5F5N	4770	22,8	180**	36**	1450	19,2		
HYD-XL																
HYD-XL 50.09	25049	50	13,2	90	1300	1450	12	SNM2NN/022 BN06GAM1F5F5N	4770	22,8	180**	36**	1450	19,2		

*) A richiesta disponibili motori idraulici Casappa - Marzocchi
 *) On request available Hydraulic Motor type: Casappa - Marzocchi
 **) Theoretical data.

HYDRAULIC DRIVE

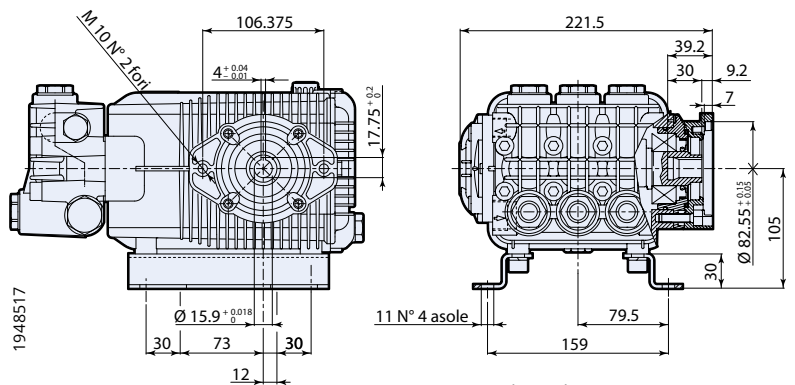

XW + F38

MOD	COD	l/min gpm		bar psi		hp kW		N° giri/1'	kg
		MAX	MAX	MAX	MAX	RPM	RPM		
XW 1450rpm + F38									
XW 30.10 + F38	21601	30	7.92	100	1450	7,5	5,5	1450	16,5
XW 30.15 + F38	22318	30	7.92	150	2200	10	7,5	1450	16,5



Flangia F38 per motori idraulici SAE A82.55 (2 fori). Flangia inclusa. F38 flange for close coupling hydraulic motors SAE A82.55 (2 holes). Flange included.



194 Series

HYDRAULIC DRIVE



lavaggio industriale
industrial cleaning



processi industriali
industrial processes



autolavaggio car wash



produzione manufacturing



agricoltura agriculture



municipality



misting



pulizia tubazioni sewer jetting





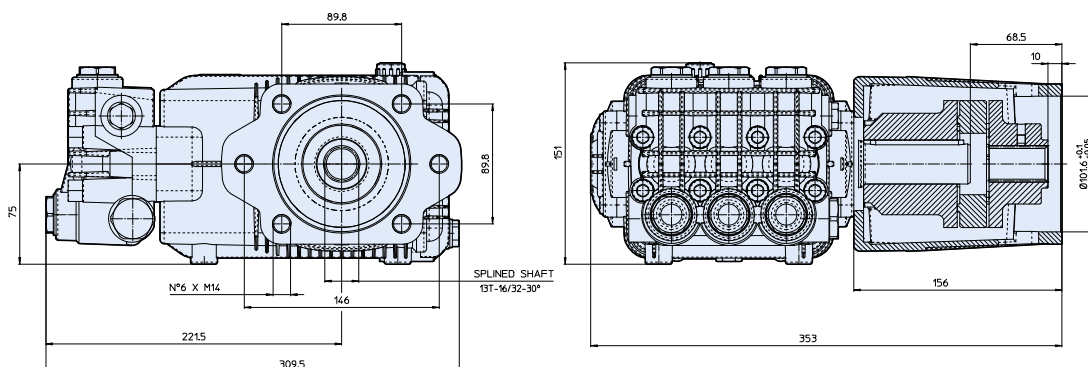

antincendio fire fighting



1948657

XW - XWL - XWP - SXW + F60

MOD	COD	 MAX	 MAX						
		l/min	gpm	bar	psi	hp	kW	N° giri/1'	kg
XW + F60									
XW 21.28 N+F60	28432	21	5.55	280	4061	20	15	1450	21
XW 30.25 N+F60	28433	30	7.92	250	3625	20	15	1450	21
XWL + F60									
XWL 42.15 N+F60	28434	42	11.09	150	2200	19	14	1450	21
XWL 50.15 N+F60	28435	50	13.2	150	2200	20	15	1450	21
XWP + F60									
XWP 60.13 N+F60	28436	60	15.9	130	1900	20	15	1450	21
XWP 70.15 N+F60	28437	70	18.5	150	2200	20	15	1450	22,5
SXW + F6022,5									
SXW 21.35 N+F60	28438	21	5.55	350	5100	20	15	1450	21

A richiesta testa nichelata · Nickel plated head available.

Per motori idraulici vedi pag. 167 · For hydraulic motors see page 167.

Pompa con flangia e giunto elastico per motori idraulici tipo SAE J498 B101-2, B101-4. Albero scanalato 13T.

Pump with bell housing + flexible coupling for hydraulic motors SAE J498 B101-2, B101-4 type. Splined shaft 13T.

NEW



testa in ottone
brass head



bielle in alluminio
aluminium connecting-rods

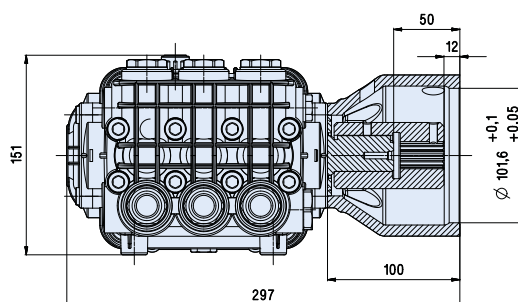
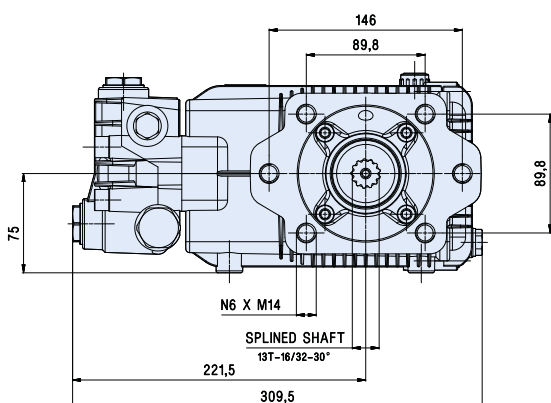

1948591

XW - XWL - XWP - SHP + F62

MOD	COD	MAX	MAX	MAX	MAX				
		l/min	gpm	bar	psi	hp	kW	N° giri/1'	kg
XW + F62									
XW 15.30 N+F62	28041	15	3.96	300	4351	12	8,7	1450	19
XW 21.25 N+F62	28042	21	5.55	250	3625	12,5	9,2	1450	19
XW 26.20 N+F62	28043	26	6.87	200	2900	12,5	9,2	1450	19
XW 30.25 N+F62	28044	30	7.92	250	3625	19	14	1450	19
XWL + F62									
XWL 36.15 N+F62	28045	36	9.51	150	2200	15	11	1450	19
XWL 41.20 N+F62	28046	41	10.8	200	2900	20	15	1450	19
XWL 50.15 N+F62	28047	50	13.2	150	2200	20	15	1450	19
XWL 50.20 N+F62	28040	50	13.2	200	2900	26,5	19,5	1450	19
XWP + F62									
XWP 50.15 N+F62	28109	50	13.2	150	2200	20	15	1450	20
XWP 55.14 N+F62	28110	55	14.5	140	2000	20	15	1450	20
XWP 60.13 N+F62	28111	60	15.9	130	1900	20	15	1450	20
XWP 65.12 N+F62	28112	65	17.2	120	1740	20	15	1450	20
XWP 70.12 N+F62	28113	70	18.5	120	1740	20	15	1450	20
XWP 70.15 N+F62	28114	70	18.5	150	2200	27	20	1450	20
SHP + F62									
SHP 15.50 N+F62	28664	15	3.96	500	7251	20	15	1450	19
SHP 22.50 N+F62	28665	22	5.8	500	7251	27	20	1450	19

A richiesta testa nichelata · Nickel plated head available.

Per motori idraulici vedi pag. 167 · For hydraulic motors see page 167.

Pompa con flangia e giunto rigido per motori idraulici tipo SAE J498 B101-2, B101-4. Albero scanalato 13T.
 Pump with bell housing + solid coupling for hydraulic motors SAE J498 B101-2, B101-4 type. Splined shaft 13T.



SHP Models

538 SERIES

RF



NEW

novità
new

Corpo e coperchi in alluminio pressofuso.

Coperchio posteriore con scarico olio.
Livello olio nel coperchio laterale.

Cuscinetti a rulli conici.

Bielle in lega zinco-alluminio o bronzo.

Testa in ottone stampato.

Pistoni in ceramica.

Crankcase and cover in pressure die-cast aluminium alloy.

Back cover incorporated with oil drain outlet. Cover lateral oil sight glass.

Tapered roller bearings.

Connecting rods in pressure die-cast zinc-aluminium alloy or bronze.

Forged brass pump head.

Ceramic plungers.



- 
lavaggio industriale
industrial cleaning
- 
processi industriali
industrial processes
- 
autolavaggio
car wash
- 
produzione
manufacturing
- 
agricoltura
agriculture
- 
municipality
- 
misting
- 
pulizia tubazioni
sewer jetting
- 
antincendio
fire fighting

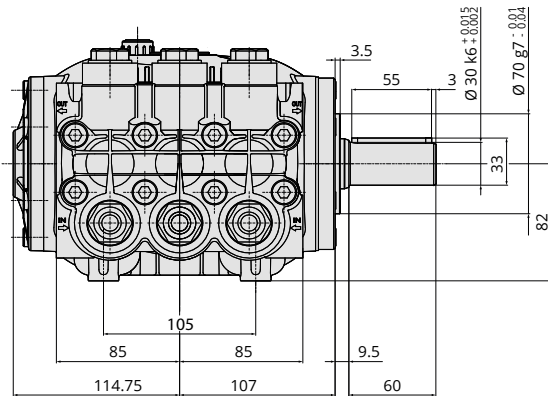
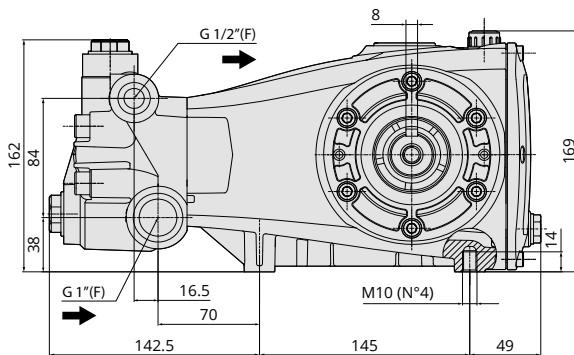

5388500

N version

MOD	COD	MAX		MAX		MAX		kg NET	
		l/min	gpm	bar	psi	hp	kW		
RF 1450rpm Nversion Ø30mm									
RF 22.400 N DX	29514	22	5.8	400	5800	22	16.5	1450	22
RF 27.400 N DX	29513	27	7.1	400	5800	27	20	1450	22
RF 36.400 N DX	29148	36	9.5	400	5800	36.2	27	1450	22
RF 39.400 N DX	29512	39	10.3	400	5800	39	29	1450	22
RFA 1750rpm Nversion Ø30mm									
RFA 7G50 N DX	29968	26.5	7	350	5000	23	17	1750	22
RFA 8G50 N DX	29969	30	8	350	5000	27	20	1750	22
RFA 10.7G50 N DX	29970	40	10.7	350	5000	36.2	27	1750	22



testa in ottone
brass head



bielle in bronzo
bronze connecting-rods

366 SERIES

RTX
RTX-I
HRTX
HYD-RTX
RTX+F54
RTX+F56



Corpo e coperchi in alluminio pressofuso.

Coperchio posteriore con scarico olio.
Livello olio nel coperchio laterale.

Cuscinetti a rulli conici.

Bielle in lega zinco-alluminio o in bronzo.

Testa in ottone stampato e nichelata.
Testa in AISI 420 per la versione RTX-I.

Pistoni in ceramica.

Crankcase and cover in pressure die-cast aluminium alloy.

Back cover incorporated with oil drain outlet.

*Cover lateral oil sight glass.
Tapered roller bearings.*

Connecting rods in pressure die-cast zinc-aluminium alloy. Bronze connecting rods available.

*Nickel-plated forged brass pump head.
Pump head in AISI 420 for RTX-I model.*

Ceramic plungers.

366 Series

POMPA ALBERO MASCHIO Solid shaft pump



- 
lavaggio industriale
industrial cleaning
- 
processi industriali
industrial processes
- 
autolavaggio
car wash
- 
produzione
manufacturing
- 
agricoltura
agriculture
- 
municipality
- 
misting
- 
pulizia tubazioni
sewer jetting
- 
antincendio
fire fighting

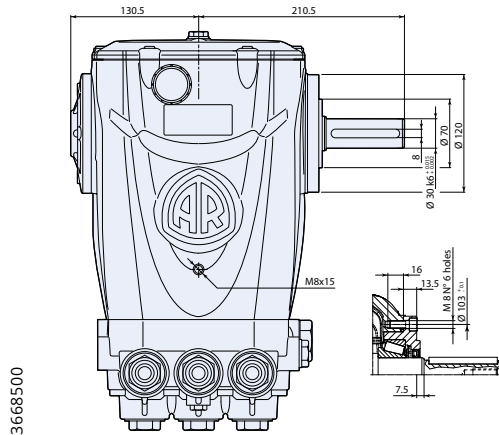
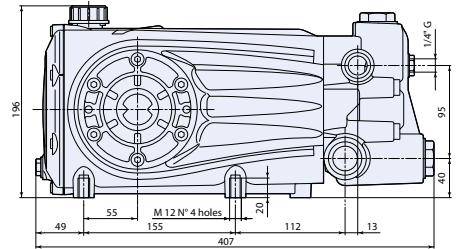
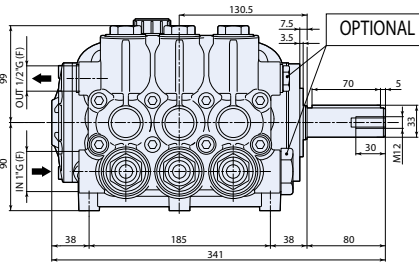

3668500

N version

MOD	COD	MAX		MAX		MAX		KG NET	
		l/min	gpm	bar	psi	hp	kW	N° giri/1'	
RTX 1450rpm Nversion Ø30mm									
RTX 30.300 N	24448	30	7,92	300	4351	24	18	1450	32,5
RTX 50.200 N	25066	50	13,2	200	2900	27	20	1450	32,5
RTX 50.300 N	26226	50	13,2	300	4351	40	30	1450	32,5
RTX 60.300 N	26068	60	15,9	300	4351	47	35	1450	32,5
RTX 70.150 N	24446	70	18,5	150	2200	30	22	1450	32,5
RTX 70.200 N DX	28258	70	18,5	200	2900	37	28	1450	32,5
RTX 70.250 N DX	29678	70	18,5	250	3600	47	35	1450	32,5
RTX 85.150 N DX	28259	85	22,5	150	2200	34	26	1450	32,5
RTX 100.120 N DX	27717	100	26,4	120	1740	30	22	1450	32,5



testa nichelata
nickel plated brass head



bielle in alluminio
aluminium connecting-rods



bielle in bronzo
bronze connecting-rods



366 Series

POMPA ALBERO MASCHIO Solid shaft pump



lavaggio industriale
industrial cleaning



processi industriali
industrial processes



autolavaggio
car wash



produzione
manufacturing



agricoltura
agriculture



municipality



misting



pulizia tubazioni
sewer jetting

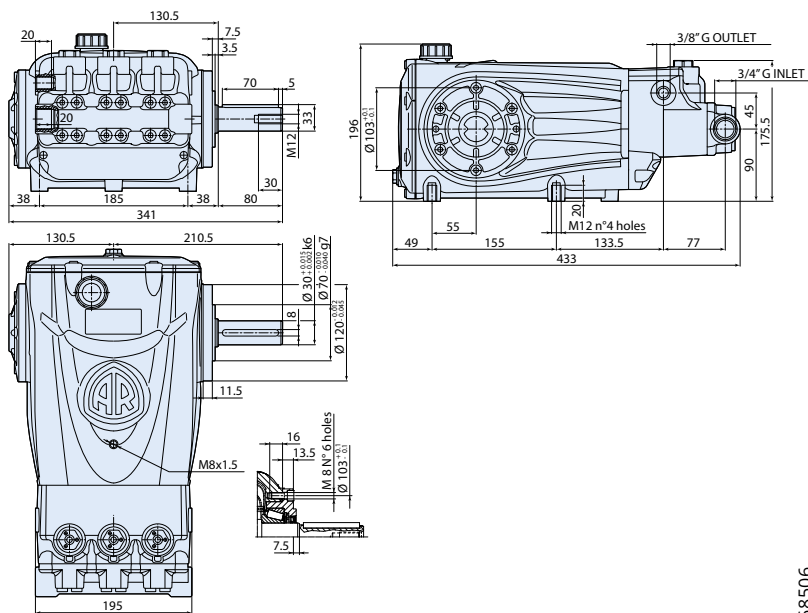

Model 600 bar

N version

MOD	COD	MAX		MAX					
		l/min	gpm	bar	psi	hp	kW	N° giri/1'	kg
RTX 1450rpm Nversion Ø30mm									
RTX 30.500 N	● 26116	30	7,92	500	7250	40	30	1450	34
RTX 35.350 N	● 27349	35	9,24	350	5076	34	26	1450	34
RTX 30.600 N	● 28984	30	7,93	600	8700	45	34	1450	34



testa nichelata
nickel plated brass head



bielle in alluminio
aluminium connecting-rods



● bielle in bronzo
bronze connecting-rods

3668506

366 Series

POMPA ALBERO MASCHIO Solid shaft pump



lavaggio industriale
industrial cleaning



processi industriali
industrial processes



autolavaggio
car wash



produzione
manufacturing



agricoltura
agriculture



municipality



misting



pulizia tubazioni
sewer jetting

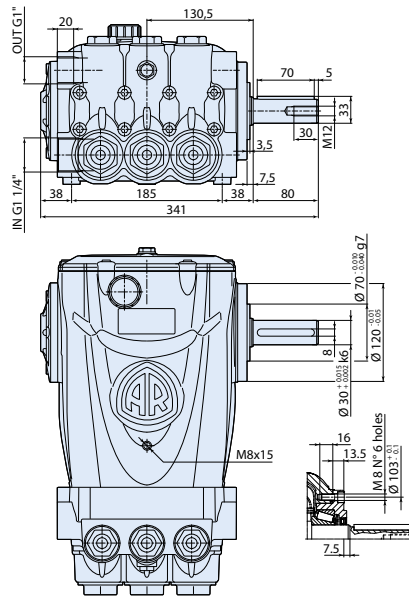

3668509

N version

MOD	COD	MAX	MAX						
		l/min	gpm	bar	psi	hp	kW	N° giri/1'	kg
RTX 1450rpm Nversion Ø30mm									
RTX 150.100 N	26485	150	39,6	100	1450	40	30	1450	35



testa nichelata
nickel plated brass head



bielle in bronzo
bronze connecting-rods

RTX-I

366 SERIES

RTX-I Stainless Steel ad alta pressione
fino a 500 bar.

- Albero in acciaio ad alta resistenza e supportato da due **cuscinetti a rulli conici** di alta qualità e sovradimensionati.
- Bielle in **bronzo**.
- Corpo pompa e coperchi laterali in lega di **alluminio ad alta resistenza** per pressofusione e con trattamento di **anodizzazione**.
- Pistoni in **ceramica** integrale.
- Sistema di tenuta a **doppia guarnizione**.
- Testa in **acciaio inox** AISI 420.
- **Valvole di costruzione robusta** per reggere le alte pressioni di utilizzo.
- Coperchio posteriore con **scarico olio**.
Livello olio laterale.

RTX-I Stainless Steel pump up to 500 bar.

- *Shaft in high-strength steel supported by two **high-quality, oversized tapered roller bearings.***
- ***Bronze** connecting rods.*
- *Pump head in **stainless steel** AISI 420.*
- *Body and side covers in **anodised die-cast high-strength aluminium alloy.***
- ***Ceramic plungers.***
- ***Double gasket sealing system.***
- ***Valves are of rugged construction** to withstand the high operating pressures.*
- *Back cover incorporated with **oil drain outlet.***
Lateral oil sight glass.



**AISI
420**

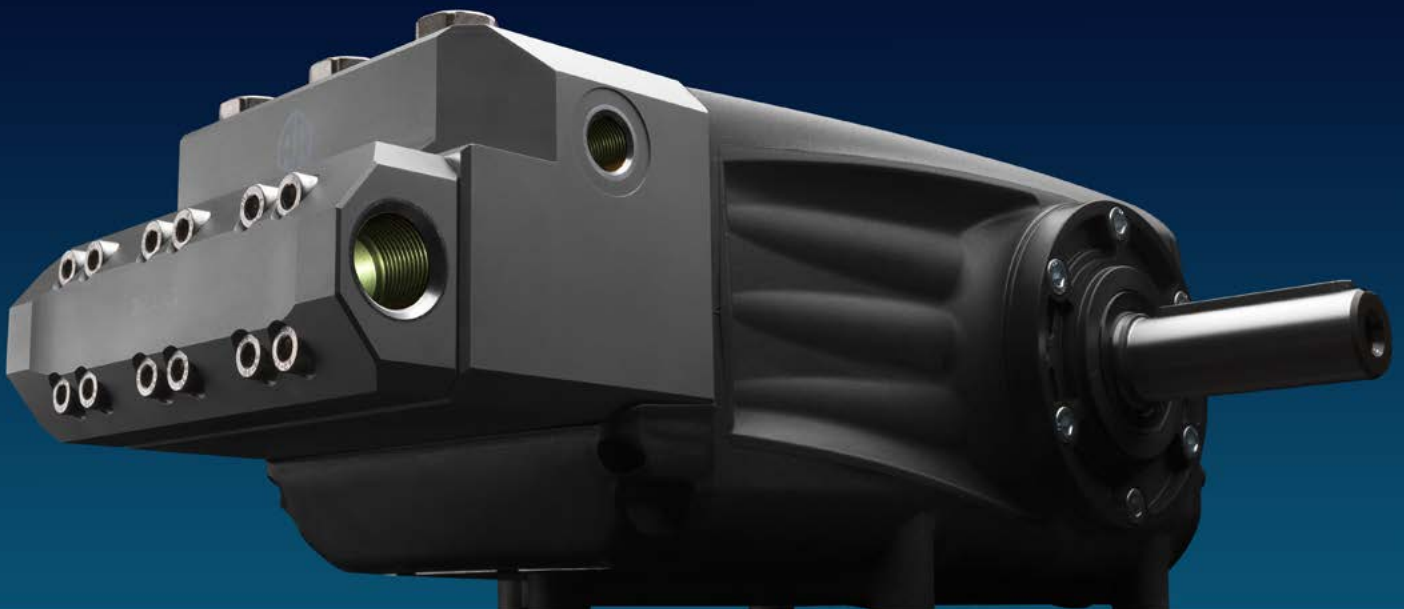

366 Series

POMPA ALBERO MASCHIO Solid shaft pump



lavaggio industriale
industrial cleaning



processi industriali
industrial processes



municipality



pulizia tubazioni
sewer jetting



cantieri ed edilizia
construction industry



settore navale
marine industry

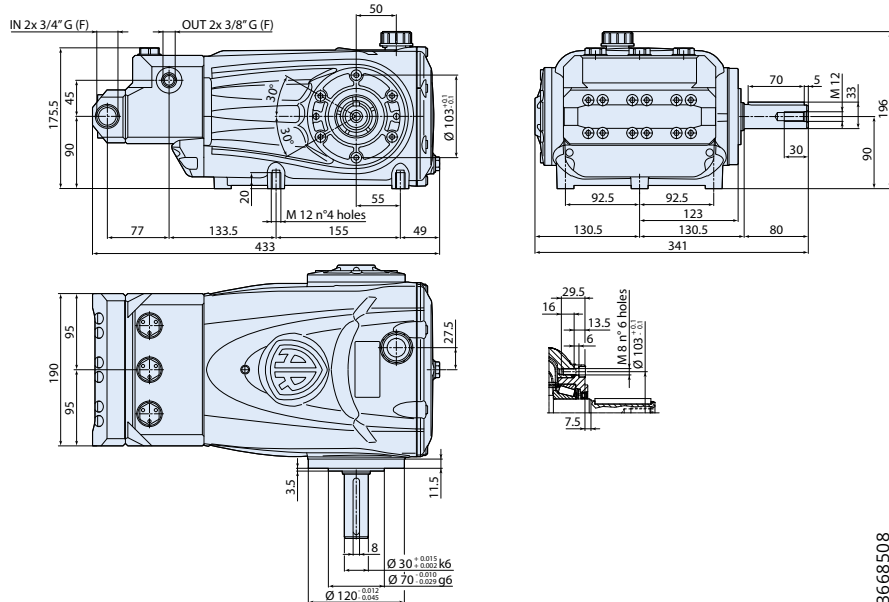

Model 600 bar

36689508

N version

MOD	COD	MAX	MAX		
		l/min gpm	bar psi	hp kW	N° giri/1' kg
RTX-I 1450rpm Nversion Ø30mm					
RTX-I 30.500 N	26611	30 7,92	500 7250	40 30	1450 34
RTX-I 30.600 N	29146	30 7,92	600 8700	45 34	1450 34



testa in AISI 420
AISI 420 pump head



bielle in bronzo
bronze connecting-rods



366 Series

POMPA ALBERO MASCHIO Solid shaft pump



lavaggio industriale
industrial cleaning



processi industriali
industrial processes



municipality



pulizia tubazioni
sewer jetting



cantieri ed edilizia
construction industry



settore navale
marine industry

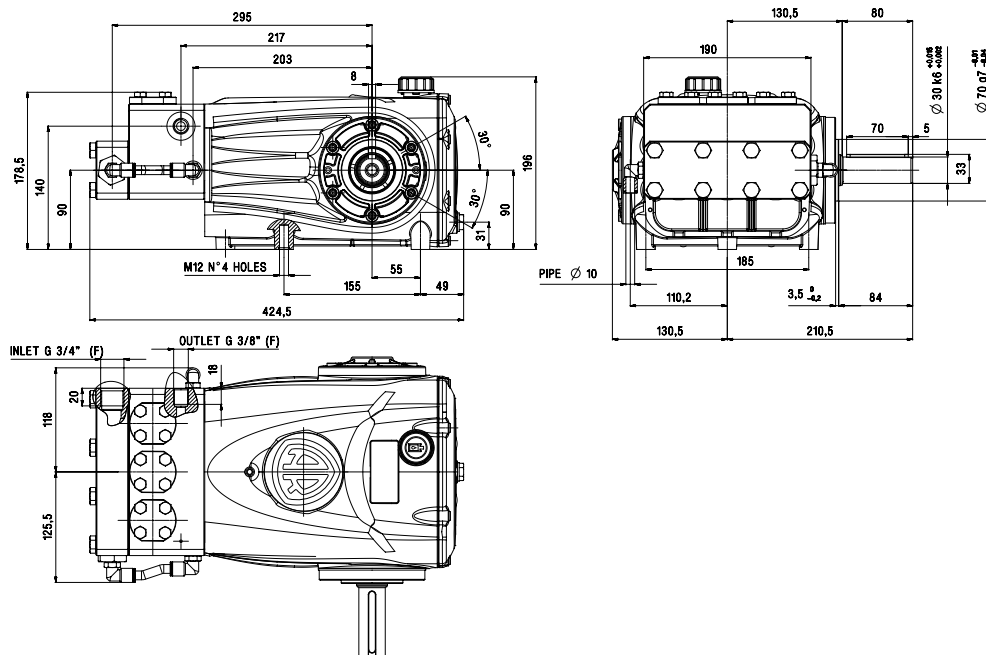

N version

MOD	COD	MAX	MAX		NET
		l/min gpm	bar psi	hp kW N° giri/1'	kg
RTX-I 1450rpm	Nversion	Ø30mm			
RTX-I 24.800 N	28954	24 6.34	800 11600	48 36 1450	34



testa in acciaio inox
inox pump head



bielle in bronzo
bronz connecting-rods



lavaggio industriale
industrial cleaning



processi industriali
industrial processes



autolavaggio
car wash



produzione
manufacturing



agricoltura
agriculture



municipality



misting



pulizia tubazioni
sewer jetting

Motore elettrico GR. 160L con giunto flessibile interno.
GR. 160L electric motor with internal flexible joint.

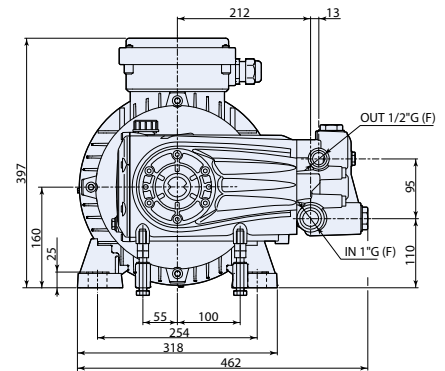
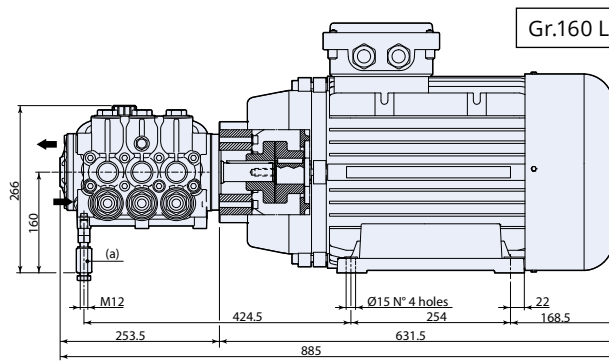

(a) Supporto pompa consigliato (M12).
Pump support recommended (M12).

3668501

MOD	COD	MAX	MAX								
	3 ~	l/min	gpm	bar	psi	hp	kW	N° giri/1'	V 3-50Hz	Gr.	kg
HRTX 1450rpm											
HRTX 30.300 ET	25344	30	7,92	300	4351	25	18,6	1450	400/690	160 L	135
HRTX 50.200 ET	25257	50	13,2	200	2900	25	18,6	1450	400/690	160 L	135
HRTX 70.150 ET	25664	70	18,5	150	2200	30	22	1450	400/690	160 L	135
HRTX 100.120 ET	25665	100	26,4	120	1740	30	22	1450	400/690	160 L	135



testa in nickel
nickel plated head



bielle in alluminio
aluminium connecting-rods



frequenza motore
motor frequency



366 Series

ELECTRIC MOTOR-PUMP UNITS



lavaggio industriale
industrial cleaning



processi industriali
industrial processes



autolavaggio
car wash



produzione
manufacturing



agricoltura
agriculture



municipality



misting



pulizia tubazioni
sewer jetting



Motore elettrico GR. 180 con giunto flessibile interno.
GR. 180 electric motor with internal flexible joint.

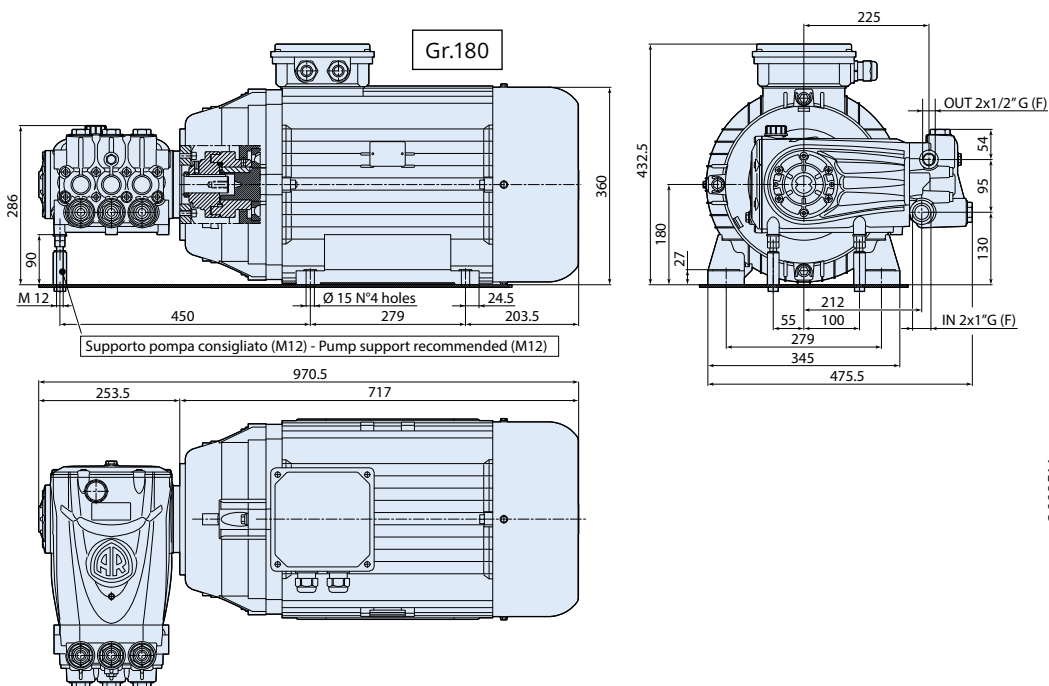

3668511

MOD	COD	3 ~	l/min	gpm	bar	psi	hp	kW	N° giri/1'	V 3-50Hz	Gr.	kg
HRTX 1450rpm												
HRTX 50.300 ET	26923	50	13,2	300	4351	40	30	1450	400/690	180	220	
HRTX 60.250 ET	26924	60	15,9	250	3625	40	30	1450	400/690	180	220	



testa in nickel
nickel plated head



bielle in alluminio
aluminium connecting-rods



frequenza motore
motor frequency



lavaggio industriale
industrial cleaning



processi industriali
industrial processes



produzione
manufacturing



municipality



Motore elettrico GR. 180 con giunto flessibile interno.
GR. 180 electric motor with internal flexible joint.

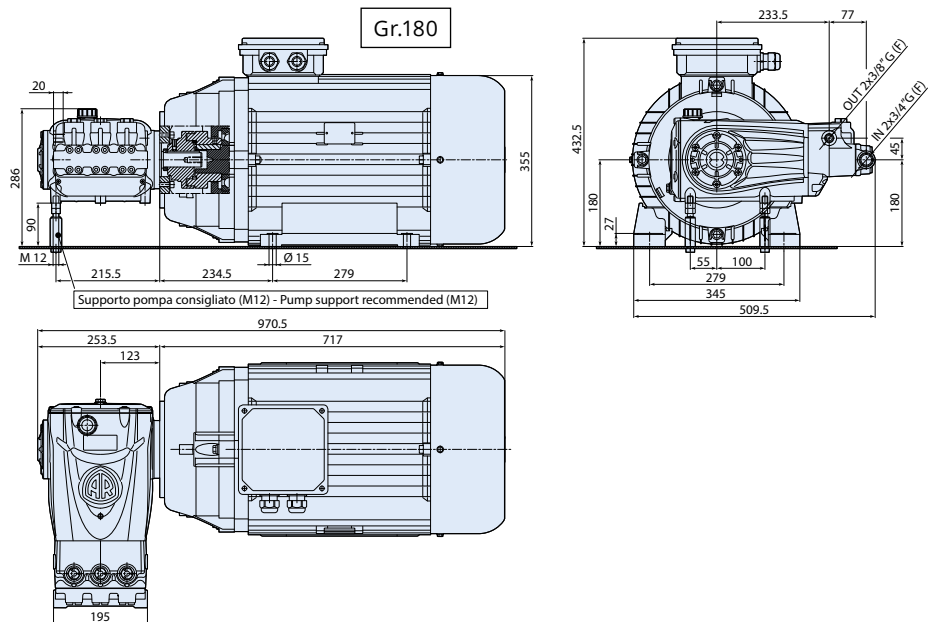

3668510

MOD	COD	MAX	MAX		NET									
	3 ~	l/min	gpm	bar	psi	hp	kW	N° giri/1'	V 3-50Hz	Gr.	kg			3~50Hz
HRTX 1450rpm														
HRTX 30.500 ET	26922	30	7,92	500	7250	40	30	1450	400/690	180	221	testa nichelata nickel plated brass head	bielle in bronzo bronze connecting-rods	frequenza motore motor frequency



366 Series

HYDRAULIC DRIVE



municipality



antincendio
fire fighting



Motor Type	A	B	C	D	E	F	G
	mm						Ø mm
SNM3NN/044 BN07GAM1A4A4 NNNN/NNNN	71	148,5	558	30,18	58,72	7/16- 14 UNC	31,8

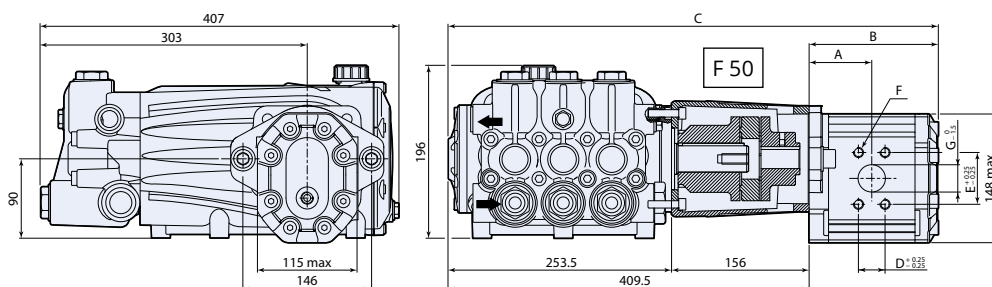

3668503

HYD - RTX



testa
nichelata
nickel plated
brass head



bielle in
alluminio
aluminium
connecting-rods



motore
idraulico
hydraulic
drive

MOD	COD	POMPA A PISTONI • HP PISTON PUMP						MOTORE IDRAULICO • HYDRAULIC MOTOR						
		SAUER DANFOSS		SAUER DANFOSS		SAUER DANFOSS		SAUER DANFOSS		SAUER DANFOSS		KG NET		
		l/min	gpm	bar	psi	RPM	hp	Type	Cod	cm ³	bar	l/min	RPM	kg
HYD-RTX														
HYD-RTX 70.150	25549	70	18,5	150	2200	1450	30	SNM3NN/044 BN07SAM1A4A4 NNNN/NNNN	45222	44,1	180*	70*	1450	42,5
HYD-RTX 70.200	26148	70	18,5	200	2900	1450	37	SNM3NN/044 BN07SAM1A4A4 NNNN/NNNN	45222	44,1	240*	70*	1450	42,5
HYD-RTX 100.120	25345	100	26,4	120	1740	1450	30	SNM3NN/044 BN07SAM1A4A4 NNNN/NNNN	45222	44,1	210*	70*	1450	42,5

*) Theoretical data.



Pompa con campana e giunto elastico per motori albero scanalato 13T o albero con linguetta.
 Pump with bell housing and flexible coupling for 13T splined shaft motors or shaft with key.

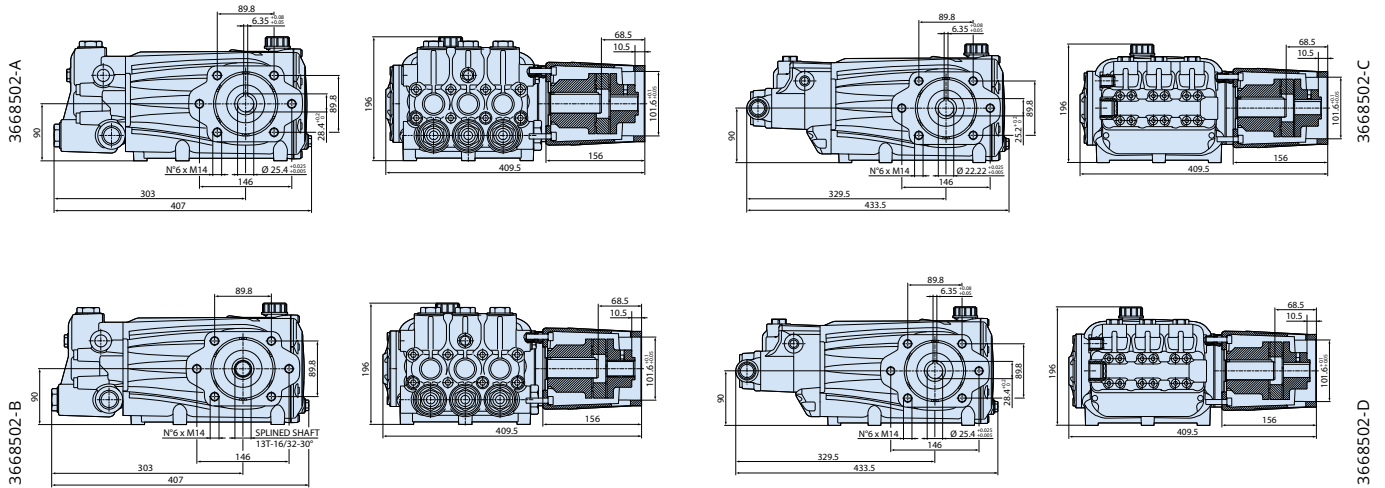

HM 44 - COD.45222 **HM 90 - COD.45223** **HM 34 - COD.45221** **HM 64 - COD.45230**

Fino a / Up to **40 hp - 30 kW**
 Fino a / Up to **47 hp - 35 kW**
 Fino a / Up to **40 hp - 30 kW**
 Fino a / Up to **47 hp - 35 kW**

RTX + F54

MOD	COD	MAX		MAX					
		l/min	gpm	bar	psi	hp	kW	N° giri/1'	kg
RTX + F54									
RTX 30.300 N+F54	28123	30	7,92	300	4351	24	18	1450	32,5
RTX 50.300 N+F54	28124	50	13,2	300	4351	40	30	1450	32,5
RTX 60.300 N+F54	28125	60	15,9	300	4351	47	35	1450	32,5
RTX 70.150 N+F54	28126	70	18,5	150	2175	30	22	1450	32,5
RTX 85.150 N+F54	28127	85	22,5	150	2175	34	26	1450	32,5
RTX 100.120 N+F54	28128	100	26,4	120	1740	30	22	1450	32,5

NEW



testa nichelata
 nickel plated
 brass head



bielle in alluminio
 aluminium
 connecting-rods

Per motori idraulici vedi pag. 167 · For hydraulic motors see page 167.



366 Series

HYDRAULIC DRIVE



- lavaggio industriale**
industrial cleaning
- processi industriali**
industrial processes
- autolavaggio**
car wash
- produzione**
manufacturing
- agricoltura**
agriculture
- municipality**
- misting**
- pulizia tubazioni**
sewer jetting
- antincendio**
fire fighting

Pompa nella versione compatta con albero femmina scanalato per motori idraulici con albero maschio scanalato 13T.
Pump with direct drive flange and hollow shaft for 13T splined shaft motors.

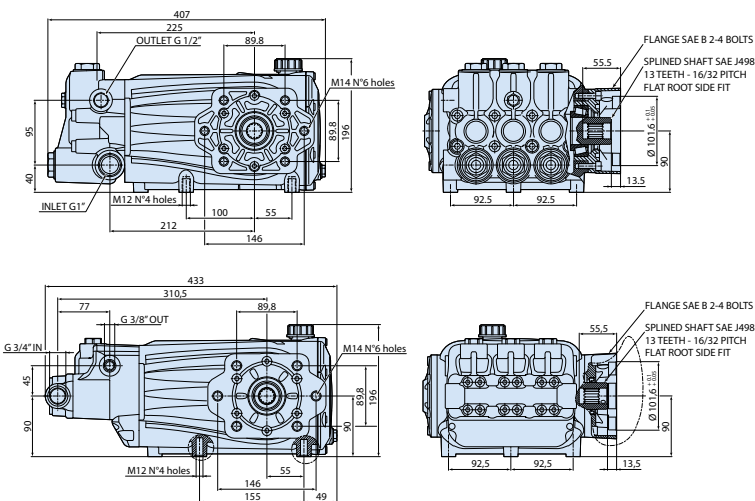

Model 500 bar

3668525

3668538

- HM 44 - COD.45222**
- HM 90 - COD.45223**
- HM 34 - COD.45221**
- HM 64 - COD.45230**



Fino a / Up to
40 hp - 30 kW



Fino a / Up to
47 hp - 35 kW



Fino a / Up to
40 hp - 30 kW



Fino a / Up to
47 hp - 35 kW

RTX + F56

MOD	COD	MAX		MAX		MAX		kg	
		l/min	gpm	bar	psi	hp	kW		
RTX + F56									
RTX 30.300 C+F56	28131	30	7,92	300	4351	24	18	1450	32,5
RTX 50.300 C+F56	28132	50	13,2	300	4351	40	30	1450	32,5
RTX 60.300 C DX+F56	27892	60	15,9	300	4351	47	35	1450	32,5
RTX 70.200 C DX+F56	27894	70	18,5	200	2900	37	28	1450	32,5
RTX 85.150 C DX+F56	27873	85	22,5	150	2175	34	26	1450	32,5
RTX 100.120 C+F56	28133	100	26,4	120	1740	30	22	1450	32,5
RTX 150.100 C DX+F56	27699	150	39,6	100	1450	40	30	1450	35
RTX 30.500C+F56	28134	30	7,92	500	7251	40	30	1450	36,5



testa nichelata
nickel plated
brass head

bielle in alluminio
aluminum
connecting-rods

Per motori idraulici vedi pag. 167 · For hydraulic motors see page 167.

418 SERIES

RTD
RTD-L
RTD+F59
RTD+F57

CR SERIES



418 SERIES

RTD
RTD-L
RTD+F59
RTD+F57



Corpo e coperchi in alluminio pressofuso.
Coperchio posteriore con scarico e livello olio.
Livello olio laterale.
Cuscinetti a rulli conici.

Bielle in lega zinco-alluminio o in bronzo.

Testa in ottone stampato. Possibilità di testa in ottone nichelata.

Pistoni in ceramica.

Crankcase and cover in pressure die-cast aluminium alloy.

Back cover incorporated with oil sight glass and oil drain outlet.

Additional side oil sight glass.

Tapered roller bearings.

Connecting rods in die-cast zinc-aluminium alloy. Bronze connecting rods available.

Pump head in forged brass. Nickel-plated brass head available.

Ceramic plungers.

418 Series

POMPA ALBERO MASCHIO Solid shaft pump



lavaggio industriale
industrial cleaning



processi industriali
industrial processes



produzione
manufacturing



agricoltura
agriculture



municipality



misting



pulizia tubazioni
sewer jetting



cantieri ed edilizia
construction industry



antincendio
fire fighting

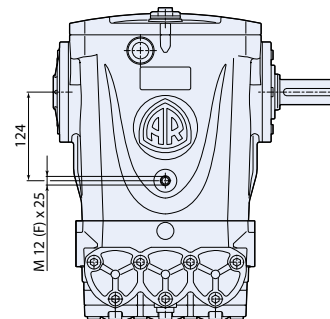
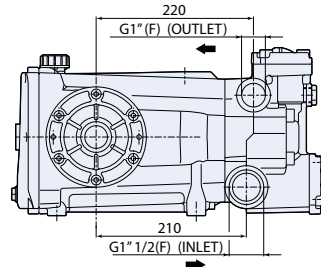
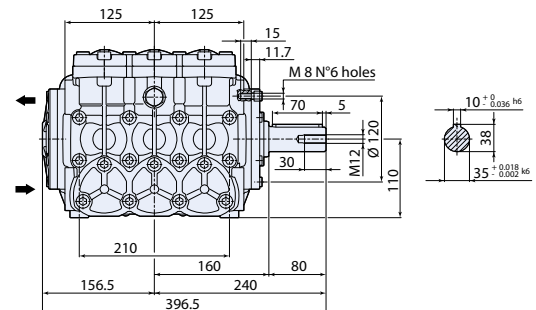
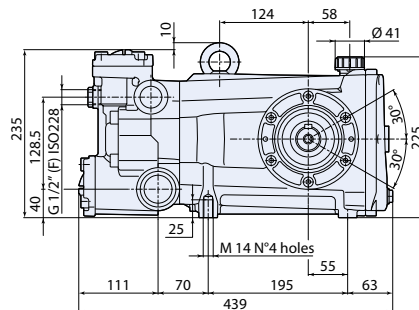

Modelli oltre 100 bar
Models over 100 bar

4188500

N version

MOD	COD	MAX	MAX						KG NET
		l/min	gpm	bar	psi	hp	kW	N° giri/1'	kg
RTD - L 800rpm Nversion Ø35mm									
RTD-L 160.100 N	● 25346	155	40,9	100	1450	42	32	800	58
RTD 950rpm Nversion Ø35mm									
RTD 200.100 N	● 27372	200	53	100	1450	51	38	950	59
RTD 1000rpm Nversion Ø35mm									
RTD 80.300 N	● 26875	80	21,1	300	4350	64	47	1000	63,8
RTD 100.200 N	● 26327	100	26,4	200	2900	55	41	1000	59
RTD 130.200 N	● 27814	130	34,3	200	2900	68	51	1000	59
RTD 130.100 N	● 25348	130	34,3	100	1450	34	26	1000	59
RTD 130.160 N	● 26105	130	34,3	160	2300	54	41	1000	59
RTD 160.100 N	● 25347	160	42,3	100	1450	42	32	1000	59
RTD 160.130 N	● 26104	160	42,3	130	1900	54	41	1000	59



testa in ottone
brass head



bielle in bronzo
bronze connecting-rods



bielle in alluminio
aluminium connecting-rods

A richiesta testa nichelata. · Nickel plated head available.



418 Series

POMPA ALBERO MASCHIO Solid shaft pump



lavaggio industriale
industrial cleaning



municipality



pulizia tubazioni
sewer jetting

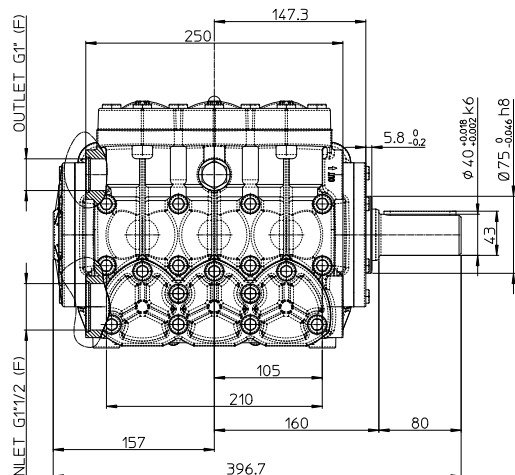
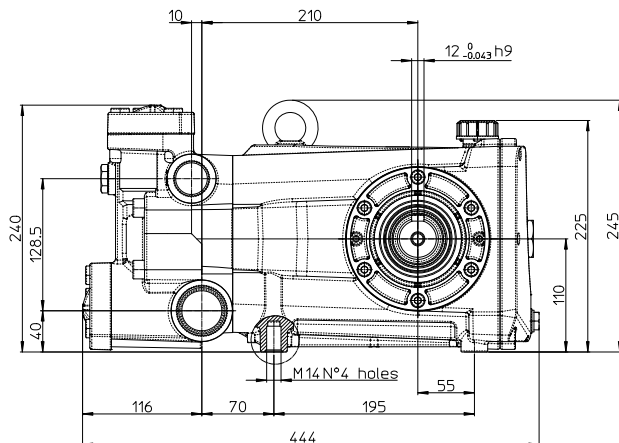

N version

MOD	COD	MAX	MAX						
		l/min	gpm	bar	psi	hp	kW	N° giri/1'	kg
RTD-J 1000rpm N version Ø40mm									
RTD-J 80.350 H N	29807	80	21.1	350	5100	75	55	1000	63.8
RTD-J 130.220 H N	29714	130	34.3	220	3200	75	55	1000	59.0
RTD-J 160.180 H N	29715	160	42.3	180	2600	75	55	1000	59.0
RTD-J 210.150 H N	29716	210	55	150	2200	80	60	1000	59.0
RTD-J 1150rpm N version Ø40mm									
RTD-J 240.140H N	29717	240	63.4	140	2000	86	64	1150	59.0

NEW



testa nichelata
nickel plated
brass head



bielle in bronzo
bronz connecting-rods



418 Series

POMPA ALBERO MASCHIO Solid shaft pump



lavaggio industriale
industrial cleaning



processi industriali
industrial processes



municipality



pulizia tubazioni
sewer jetting



cantieri ed edilizia
construction industry

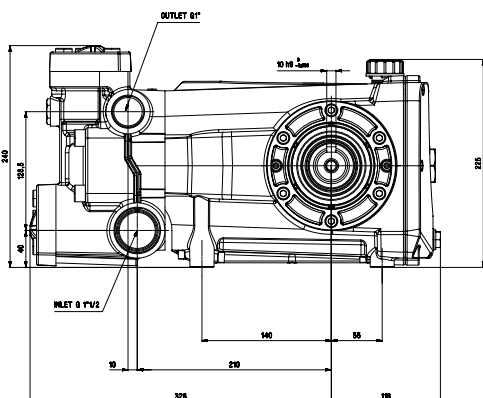

4188522

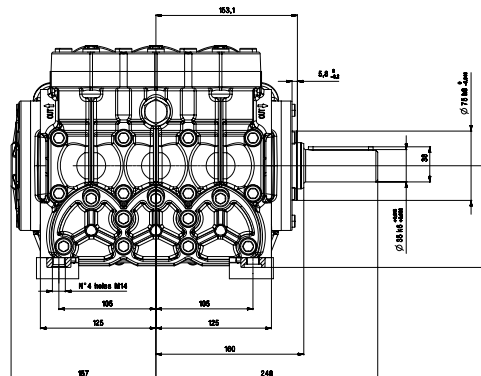

N version

MOD	COD	MAX	MAX		NET				
		l/min	gpm	bar	psi	hp	kW	N° giri/1'	kg
RTD 950rpm Nversion Ø35mm									
RTD 200.80 N	29273	200	53	80	1160	41	31	950	59
RTD 200.100 N	28450	200	53	100	1450	51	38	950	59

NEW



testa in ghisa nichelata
nickel plated cast-iron brass head



bielle in bronzo
bronze connecting-rods



bielle in alluminio
aluminium connecting-rods



- lavaggio industriale**
industrial cleaning
- processi industriali**
industrial processes
- produzione**
manufacturing
- agricoltura**
agriculture
- municipality**
- misting**
- pulizia tubazioni**
sewer jetting
- cantieri ed edilizia**
construction industry
- antincendio**
fire fighting

Pompa con campana e giunto elastico per motori albero scanalato 14T o albero con linguetta.
Pump with bell housing and flexible coupling for 14T splined shaft motors or shaft with key.

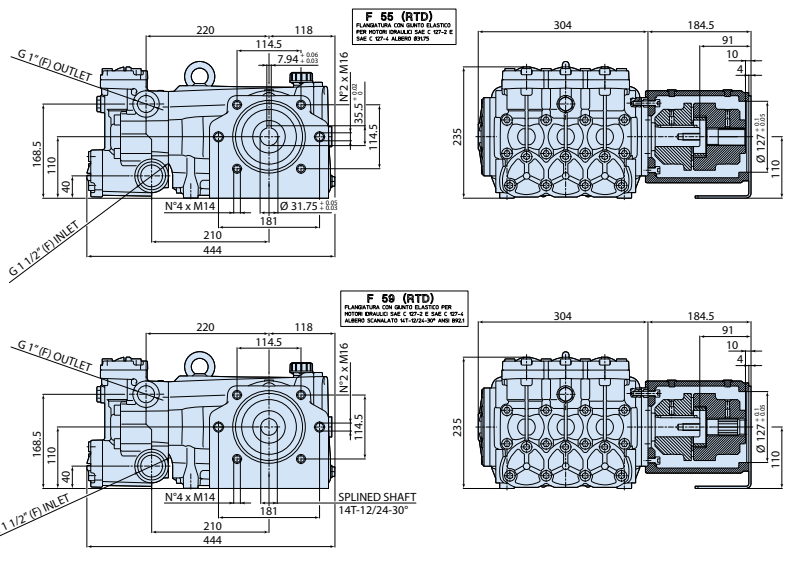

Modelli oltre 100 bar
Models over 100 bar

HM 84 - COD.45232



Fino a / Up to
70 hp - 51 kW

RTD + F59

MOD	COD	MAX		MAX		MAX		N° giri/1'	kg NET
		l/min	gpm	bar	psi	hp	kW		
RTD + F59									
RTD-L 160.100 N DX+F59	28142	155	40,9	100	1450	42	32	800	70
RTD 80.300 N DX +F59	28135	80	21,1	300	4350	64	47	1000	70
RTD 100.200 N DX+F59	28136	100	26,4	200	2900	55	41	1000	70
RTD 130.100 N DX+F59	28137	130	34,3	100	1450	34	26	1000	70
RTD 130.160 N DX+F59	28138	130	34,3	160	2300	54	41	1000	70
RTD 130.200 N DX+F59	28139	130	34,3	200	2900	68	51	1000	70
RTD 160.100 N DX+F59	28140	160	42,3	100	1450	42	32	1000	70
RTD 160.130 N DX+F59	28141	160	42,3	130	1900	54	41	1000	70

A richiesta testa nichelata · Nickel plated head available.

Per motori idraulici vedi pag. 167 · For hydraulic motors see page 167.



testa in ottone
brass head



bielle in alluminio
aluminium connecting-rods



bielle in bronzo
bronze connecting-rods



418 Series

HYDRAULIC DRIVE



lavaggio industriale industrial cleaning	processi industriali industrial processes	produzione manufacturing	agricoltura agriculture	municipality
misting	pulizia tubazioni sewer jetting	cantieri ed edilizia construction industry	antincendio fire fighting	

Pompa nella versione compatta con albero scanalato 14T.
Pump with direct drive flange and hollow shaft for 14T splined shaft motors.

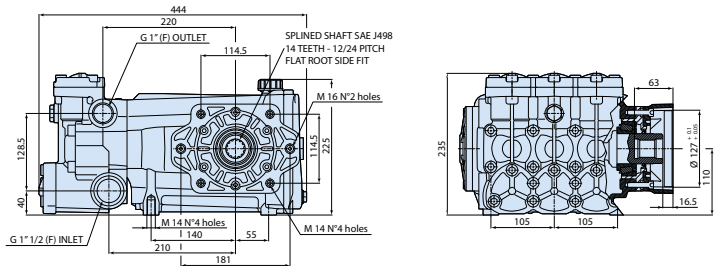

HM 84 - COD.45232



Fino a / Up to
70 hp - 51 kW

RTD + F57

MOD	COD	MAX		MAX		MAX		N° giri/1'	kg
		l/min	gpm	bar	psi	hp	kW		
RTD + F57									
RTD 100.200 C DX+F57	28165	100	26,4	200	2900	55	41	1000	62
RTD 130.160 C DX+F57	27762	130	34,3	160	2320	54	41	1000	62
RTD 130.200 C DX+F57	28056	130	34,3	200	2900	68	51	1000	62
RTD 160.130 C DX+F57	27442	160	42,3	130	1900	54	41	1000	62

A richiesta testa nichelata · Nickel plated head available.
Per motori idraulici vedi pag. 167 · For hydraulic motors see page 167.

NEW

bielle in bronzo bronze connecting-rods	testa in ottone brass head

CR SERIES

418 SERIES

CR SERIES Stainless Steel ad alta pressione **fino a 1000 bar.**

- Albero a gomiti in **acciaio stampato ad alta resistenza.**
- Bielle in **bronzo antifrizione.**
- Corpo pompa e coperchi in lega di **alluminio pressofuso** con trattamento di **anodizzazione.**
- Specola livello olio **laterale e posteriore.**
- Lubrificazione a sbattimento.
- Pistoni in **carburo di tungsteno.**
- Sistema di tenuta a **doppia guarnizione.**
- Circuito per il **raffreddamento delle guarnizioni alta pressione** per una maggiore durata.
- Testa in **acciaio inox ad alta resistenza.**
- Valvole aspirazione/mandata **inox** con geometria studiata per **ridurre le usure.**

CR SERIES Stainless Steel pump up to 1000 bar.

- **High resistance forged alloy steel** crankshaft.
- **Low friction Bronze** connecting rods.
- Crankcase and covers in **anodised die-cast aluminium alloy.**
- **Lateral and back side oil sight glass.**
- **Splash lubrication.**
- **Tungsten carbide** plungers.
- **Double gasket sealing system.**
- **Cooling system for the high pressure seals** for a longer life.
- **Pump head in high resistance stainless steel.**
- **Inox** suctions/delivery valves with geometry designed to **reduce wear.**

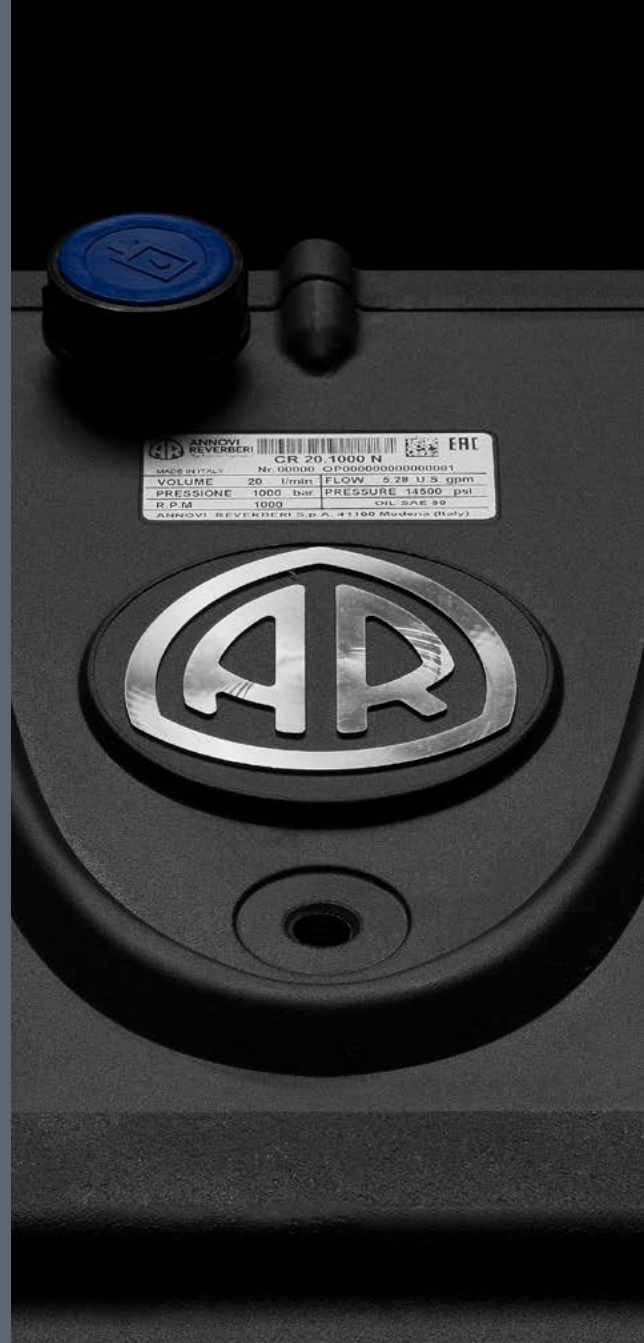

NEW

CR SERIES
Handbuilt in Italy



418 SERIES

CR SERIES



Corpo e coperchi in alluminio pressofuso.

Specola livello olio laterale e posteriore

Circuito per il raffreddamento delle guarnizioni alta pressione per una maggiore durata.

Cuscinetti a rulli conici.

Bielle in bronzo.

Testa lavorata dal pieno in acciaio inox ad alta resistenza per raggiungere altissime prestazioni.

Pistoni in carburo di tungsteno.

Valvole aspirazione/mandata coassiali.

Crankcase and cover in pressure die-cast aluminium alloy.

Lateral and back side oil sight glass.

Cooling system for the high pressure seals for a longer life.

Tapered roller bearings.

Bronze connecting rods.

Head machined from solid high resistance stainless steel billet for higher performances.

Tungsten carbide plungers.

In-line suction/delivery valves.

418 Series

POMPA ALBERO MASCHIO Solid shaft pump



lavaggio industriale
industrial cleaning



processi industriali
industrial processes



municipality



pulizia tubazioni
sewer jetting



cantieri ed edilizia
construction industry



settore navale
marine industry

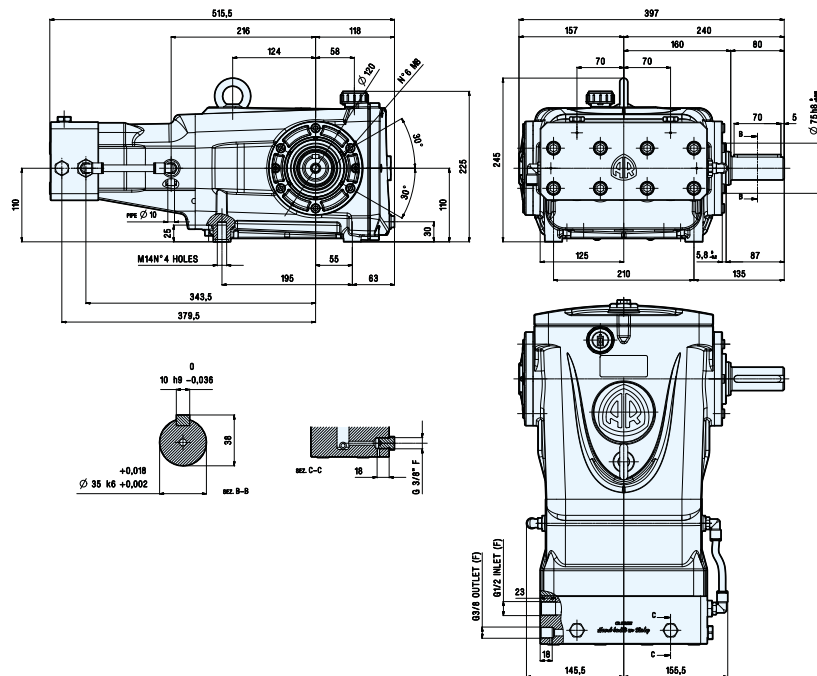

4188511

N version

MOD	COD	MAX		MAX		MAX		KG NET
		l/min	gpm	bar	psi	hp	kW	N° giri/1'
CR 1000rpm Nversion $\varnothing 35\text{mm}$								
CR 8.1000 N DX	28879	8	2,11	1000	14500	20	15	1000
CR 15.1000 N DX	28512	15	3,96	1000	14500	40	30	1000
CR 18.1000 N DX	28511	18	4,75	1000	14500	47	35	1000
CR 20.800 N DX	28859	20	5,3	800	11600	40	30	1000
CR 20.1000 N DX	27803	20	5,30	1000	14500	52	39	1000
CR 23.1000 N DX	28983	23	6	1000	14500	60	45	1000
CR 26.1000 N DX	29080	26	6,9	1000	14500	67	50	1000



testa in acciaio inox
inox pump head



bielle in bronzo
bronze connecting-rods



NEW

STAINLESS STEEL

RC-SS
XM-SS
XMA-SS
RK-SS
RKA-SS

JK-SS
HYD RK-SS
XWL-SS
RTX-SS



AISI 316 L

Corpo pompa in alluminio pressofuso e sottoposto poi a trattamento di verniciatura in cataforesi.

Testa lavorata dal pieno in acciaio AISI-316L per resistere ad atmosfere saline e acide.

Bielle in lega zinco-alluminio o in bronzo.

Albero in acciaio stampato e trattato termicamente per garantire elevata resistenza meccanica.

Pistoni in ceramica.

Crankcase in pressure die-cast aluminium alloy with cataphoresis treatment.

Head machined from solid AISI 316L steel billet for resistance to saline and acid environments.

Connecting rods in pressure die-cast zinc-aluminium alloy. Bronze connecting rods available.

Crankshaft in heat-treated pressed steel for excellent mechanical strength.

Ceramic plungers.

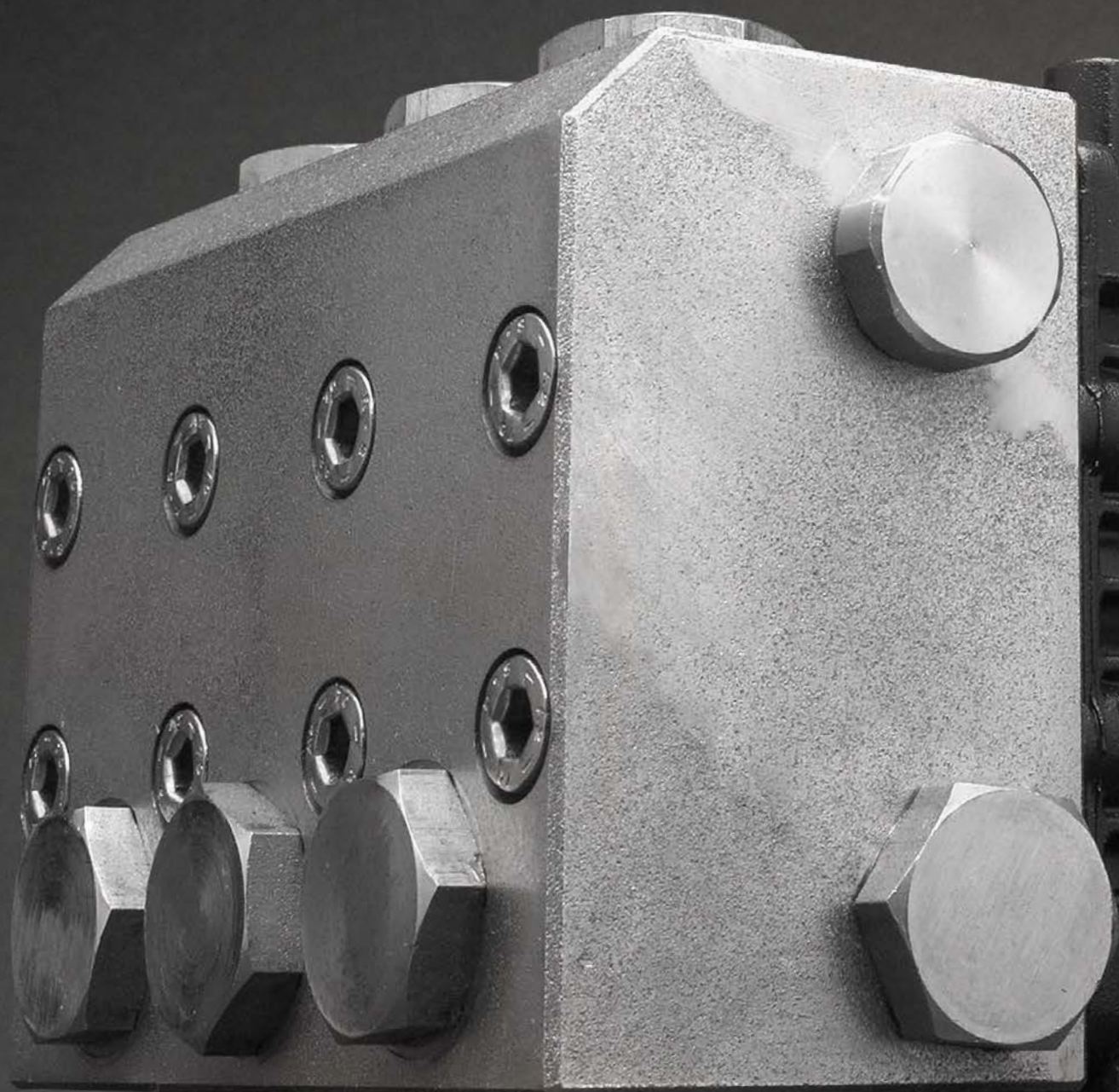

Stainless Steel

POMPA ALBERO CAVO Hollow shaft pump

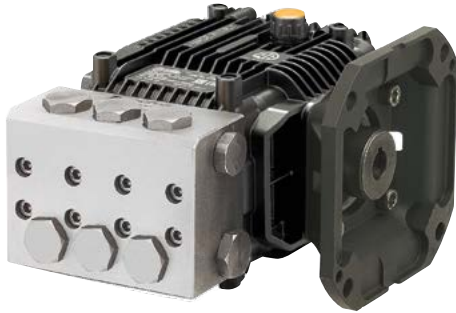

industria
alimentare
food
industry



settore
navale
marine
industry

E version + F33

MOD	COD	MAX		MAX		MAX		N° giri/1'	KG NET
		l/min	gpm	bar	psi	hp	kW		
XMA-SS 1750rpm Eversion + F33 Ø 5/8"									
XMA-SS 0.5G15 E + F33	21435	1,9	0,5	103	1500	0,6	0,4	1750	7
XMA-SS 2.5G15 E + F33	21436	9,5	2,5	103	1500	2,5	1,8	1750	7
XMA-SS 3G15 E + F33	21437	11,4	3	103	1500	3	2,2	1750	7

Flangia F33 per motori elettrici NEMA 56-C, 4 poli 60Hz. Flangia inclusa.
F33 flange for electric motor NEMA 56-C, 4 poles 60Hz Flange included.



testa in AISI 316L
AISI 316L
pump head



bielle in bronzo
bronze
connecting-rods



O-Ring in Viton
Viton
O-Rings



POMPA ALBERO MASCHIO Solid shaft pump

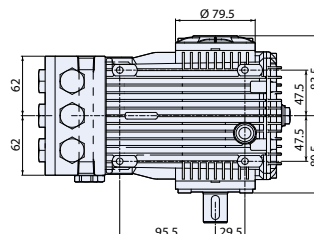
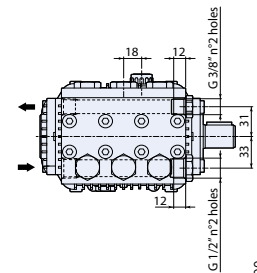
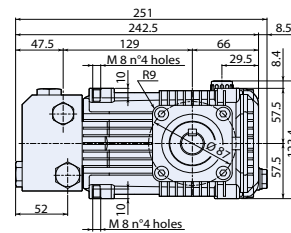
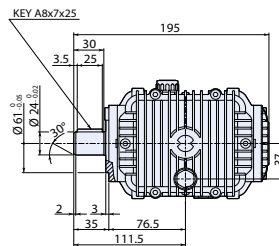

2348500



industria
alimentare
food
industry



settore
navale
marine
industry

N version

MOD	COD	MAX		MAX		MAX		N° giri/1'	KG NET
		l/min	gpm	bar	psi	hp	kW		
RK-SS 1450rpm Nversion Ø24mm									
RK-SS 11.11 N	20958	11	2,90	110	1600	3	2,2	1450	10
RK-SS 13.17 N	20959	13	3,43	170	2500	5,5	4	1450	10
RK-SS 15.15 N	20960	15	3,96	150	2200	5,5	4	1450	10
RK-SS 21.15 N	21368	21	5,55	150	2200	7,5	5,5	1450	10



testa in AISI 316L
AISI 316L
pump head



bielle in bronzo
bronze
connecting-rods



O-Ring in Viton
Viton
O-Rings



Stainless Steel

POMPA ALBERO CAVO Hollow shaft pump



industria alimentare
food industry

settore navale
marine industry

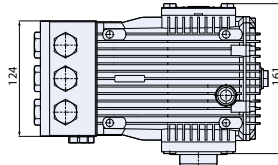
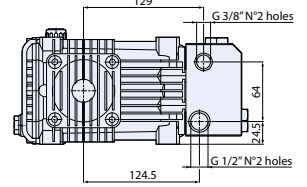
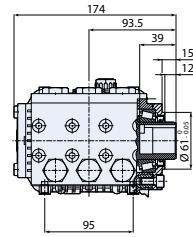
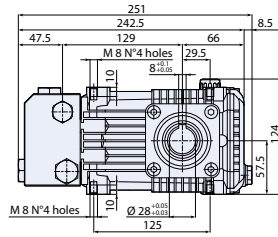

C version

MOD	COD	MAX	MAX					KG NET	
		l/min	gpm	bar	psi	hp	kW	N° giri/1'	kg
RK-SS 1450rpm Cversion Ø 28mm									
RK-SS 11.11 C	20961	11	2,90	110	1600	3	2,2	1450	10
RK-SS 13.17 C	20962	13	3,43	170	2500	5,5	4	1450	10
RK-SS 15.15 C	20963	15	3,96	150	2200	5,5	4	1450	10
RK-SS 21.15 C	21369	21	5,55	150	2200	7,5	5,5	1450	10



testa in AISI 316L
AISI 316L pump head



bielle in bronzo
bronze connecting-rods



O-Ring in Viton
Viton O-Rings

Flangia F16 per motori elettrici B14 Gr.100÷112 IEC34-7, 4 poli 50Hz. Flangia non inclusa.
F16 flange for electric motor B14 100÷112 IEC34-7, 4 poles 50Hz. Flange not included.

2348511

POMPA ALBERO MASCHIO Solid shaft pump

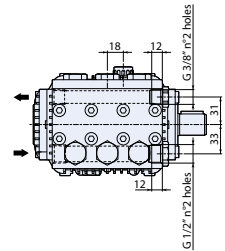
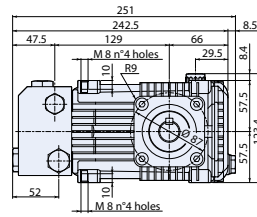
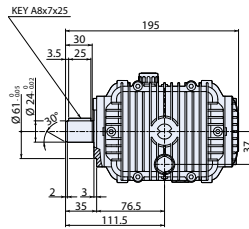

industria alimentare
food industry

settore navale
marine industry

N version

MOD	COD	MAX	MAX					KG NET	
		l/min	gpm	bar	psi	hp	kW	N° giri/1'	kg
RKA-SS 1750rpm Nversion Ø24mm									
RKA-SS 2.3G15 N	20964	8,7	2,3	103	1500	2,4	1,8	1750	10
RKA-SS 3G15 N	20965	11,4	3	103	1500	3	2,2	1750	10
RKA-SS 3.6G12 N	20966	13,6	3,6	83	1200	3	2,2	1750	10
RKA-SS 4.2G15 N	20967	15,9	4,2	103	1500	4,3	3,2	1750	10
RKA-SS 7G22 N	21195	27	7,1	150	2200	11	8,2	1750	10



testa in AISI 316L
AISI 316L pump head



bielle in bronzo
bronze connecting-rods



O-Ring in Viton
Viton O-Rings

2348500

Stainless Steel

POMPA ALBERO CAVO Hollow shaft pump

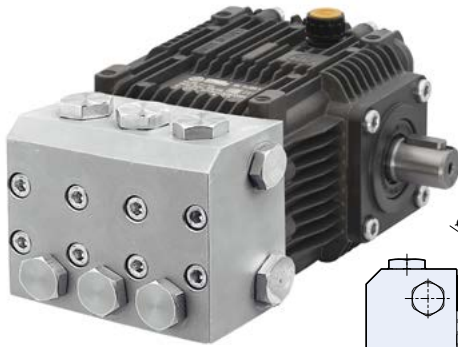



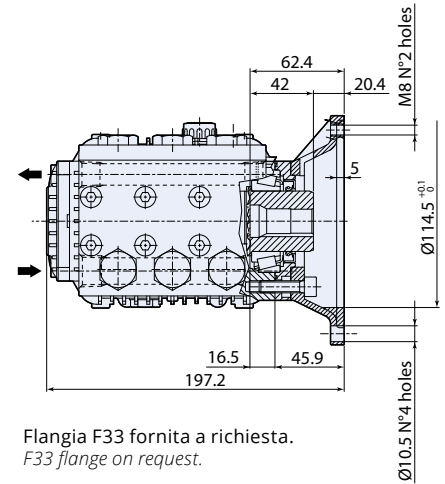
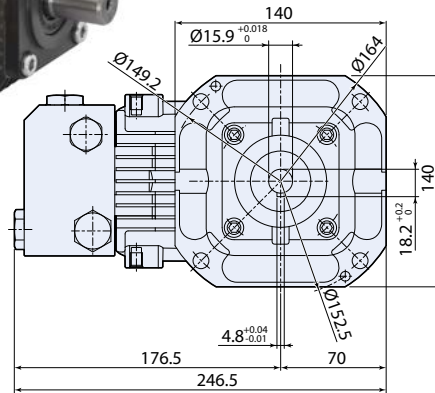

2348501



Flangia F33 fornita a richiesta.
F33 flange on request.

E version

MOD	COD	 MAX	 MAX						
		l/min	gpm	bar	psi	hp	kW	N° giri/1'	kg
RKA-SS 1750rpm E version Ø 5/8"									
RKA-SS 2.3G15 E	20968	8,7	2,3	103	1500	2,4	1,8	1750	10
RKA-SS 3G15 E	20969	11,4	3	103	1500	3	2,2	1750	10
RKA-SS 3.6G12 E	20970	13,6	3,6	83	1200	3	2,2	1750	10
RKA-SS 4.2G15 E	20971	15,9	4,2	103	1500	4,3	3,2	1750	10



testa in AISI 316L
AISI 316L pump head

bielle in bronzo
bronze connecting-rods

O-Ring in Viton
Viton O-Rings

Flangia F33 per motori elettrici NEMA 56-C, 4 poli 60Hz. Flangia non inclusa.
F33 flange for electric motor NEMA 56-C, 4 poles 60Hz. Flange not included.



2348502

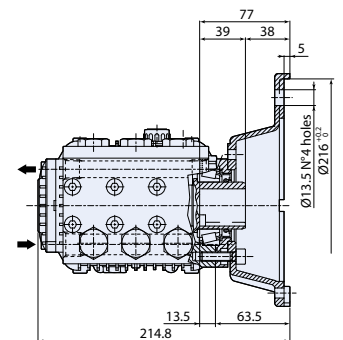
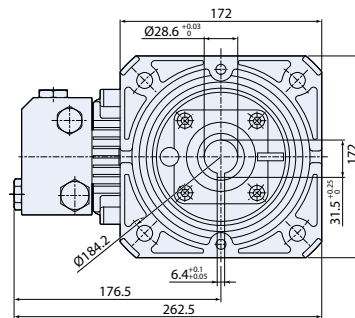

Flangia F17 fornita a richiesta.
F17 flange on request.





POMPA ALBERO CAVO Hollow shaft pump



industria alimentare
food industry

settore navale
marine industry

E version

MOD	COD	 MAX	 MAX						
		l/min	gpm	bar	psi	hp	kW	N° giri/1'	kg
RKA-SS 1750rpm E version Ø 1" 1/8									
RKA-SS 2.3G15 E	20972	8,7	2,3	103	1500	2,4	1,8	1750	10
RKA-SS 3G15 E	20973	11,4	3	103	1500	3	2,2	1750	10
RKA-SS 3.6G12 E	20974	13,6	3,6	83	1200	3	2,2	1750	10
RKA-SS 4.2G15 E	20975	15,9	4,2	103	1500	4,3	3,2	1750	10



testa in AISI 316L
AISI 316L pump head

bielle in bronzo
bronze connecting-rods

O-Ring in Viton
Viton O-Rings

Flangia F17 per motori elettrici NEMA 182÷184, 4 poli 60Hz. Flangia non inclusa.
F17 Flange for electric motor NEMA 182÷184, 4 poles 60Hz. Flange not included.



Stainless Steel

POMPA ALBERO MASCHIO Solid shaft pump



industria
alimentare
food
industry



settore
navale
marine
industry

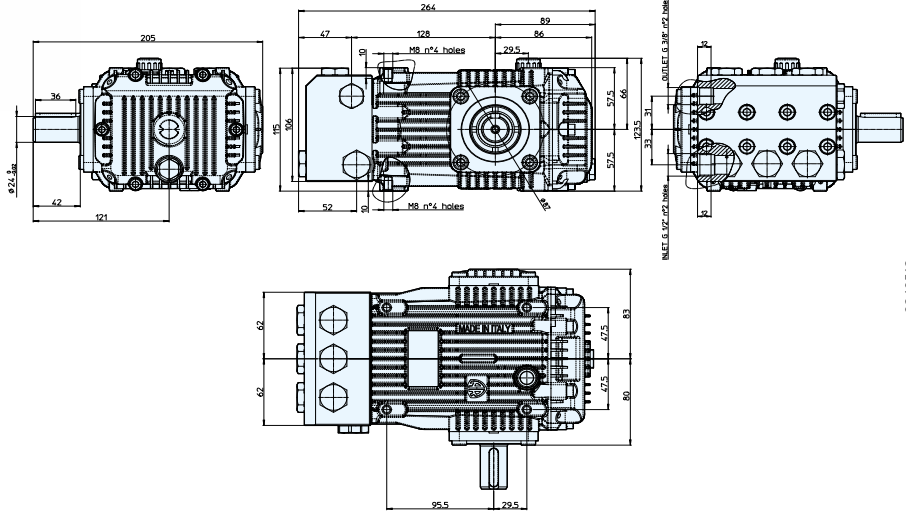

2348513

N version

MOD	COD	MAX		MAX		hp	kW	N° giri/1'	kg NET
		l/min	gpm	bar	psi				
JK - SS 1450rpm Nversion Ø24mm									
JK-SS 15.15 N	28326	15	3,96	150	2200	5,5	4	1450	10
JK-SS 21.15 N	28327	21	5,55	150	2200	7,5	5,5	1450	10



testa in AISI 316L
AISI 316L
pump head



bielle in bronzo
bronze
connecting-rods



Premium Series
LOW MAINTENANCE
HIGH EFFICIENCY

Stainless Steel

HYDRAULIC DRIVE



municipality
settore navale
 marine industry



testa in AISI 316L
AISI 316L
pump head









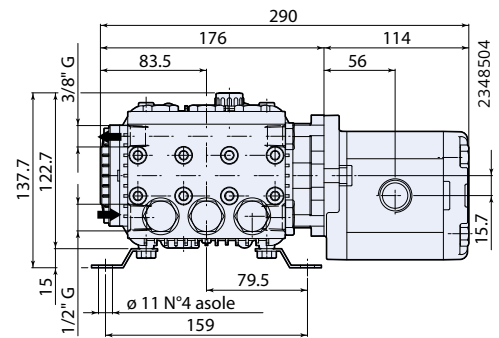
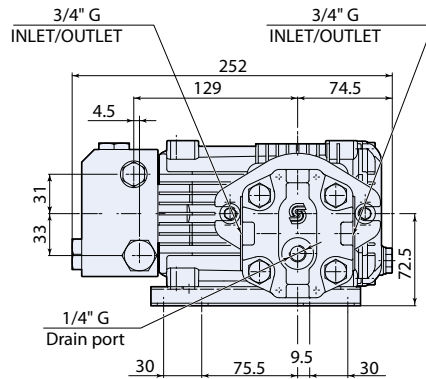



bielle in bronzo
bronze
connecting-rods



motore idraulico
hydraulic
drive



HYD RK-SS

MOD	COD	HP PISTON PUMP • POMPA A PISTONI						HYDRAULIC MOTOR • MOTORE IDRAULICO						KG NET
		 MAX	 MAX	 RPM		 MAX	 RPM	 MAX	 RPM	 MAX	 RPM			
		l/min	gpm	bar	psi	N° giri/1'	hp	Type	Cod	cm ³	bar	l/min	N° giri/1'	kg
HYD RK-SS 1450rpm														
HYD RK-SS 21.15	21965	21	5,55	150	2200	1450	7,5	SNM2NN/019 BN06GAM1F5F5N	4769	19,2	150**	29**	1450	13,5

*) A richiesta disponibili motori idraulici Casappa - Marzocchi
 *) On request available Hydraulic Motor type: Casappa - Marzocchi
 **) Theoretical data.



Stainless Steel

POMPA ALBERO MASCHIO Solid shaft pump



industria
alimentare
food
industry



settore
navale
marine
industry

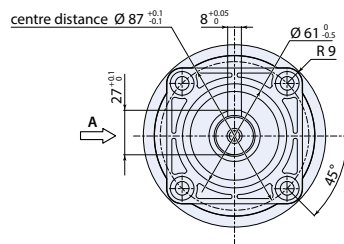
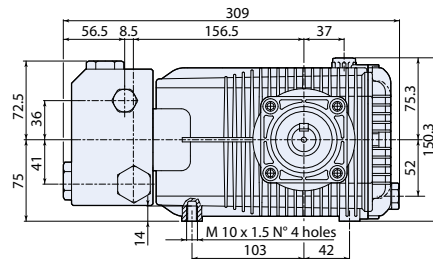

2528500

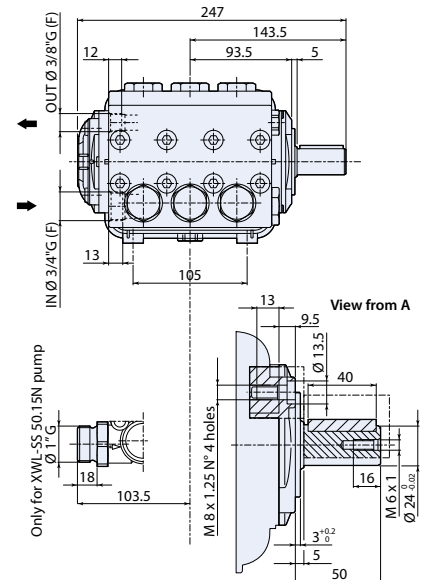

N version

MOD	COD	MAX		MAX		hp	kW	N° giri/1'	KG NET	
		l/min	gpm	bar	psi					
XWL - SS 950rpm Nversion Ø24mm										
XWL-SS 33.06 N	22831	33	8,72	60	900	5,5	4	950	18	
XWL-SS 33.08 N	23141	33	8,72	80	1160	7,5	5,5	950	18	
XWL - SS 1450rpm Nversion Ø24mm										
XWL-SS 26.06 N	22478	26	6,87	60	900	4	3	1450	18	
XWL-SS 30.09 N	22752	30	7,92	90	1300	7,5	5,5	1450	18	
XWL-SS 42.05 N	21468	42	11,09	50	725	5,5	4	1450	18	
XWL-SS 42.15 N	21704	42	11,09	150	2200	15	11	1450	18	
XWL-SS 50.15 N *	24105	50	13,2	150	2200	20	15	1450	18	

* Minimo +0,1 bar (+1,5 psi) di pressione in entrata. • Min. +0,1 bar (+1,5 psi) inlet pressure.



testa in AISI 316L
AISI 316L
pump head



bielle in alluminio
aluminium
connecting-rods



O-Ring in Viton
Viton
O-Rings

Stainless Steel

POMPA ALBERO MASCHIO Solid shaft pump



industria alimentare
food industry

settore navale
marine industry

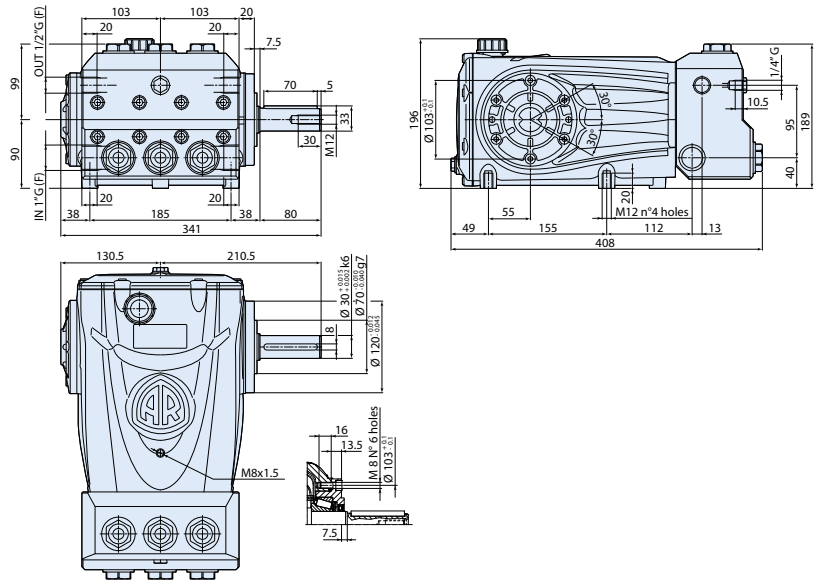

4048500

N version

MOD	COD	MAX	MAX		NET				
		l/min	gpm	bar	psi	hp	kW	N° giri/1'	kg
RTX - SS 1450rpm Nversion Ø30mm									
RTX-SS 100.100 N	26136	100	26,4	100	1450	24	18	1450	39



testa in AISI 316L
AISI 316L
pump head



bielle in alluminio
aluminium
connecting-rods



O-Ring in Viton
Viton
O-Rings

ADDITIONAL ELECTRIC MOTOR

HPV
HPV-O
HPV-MO
HPE
HPE-M

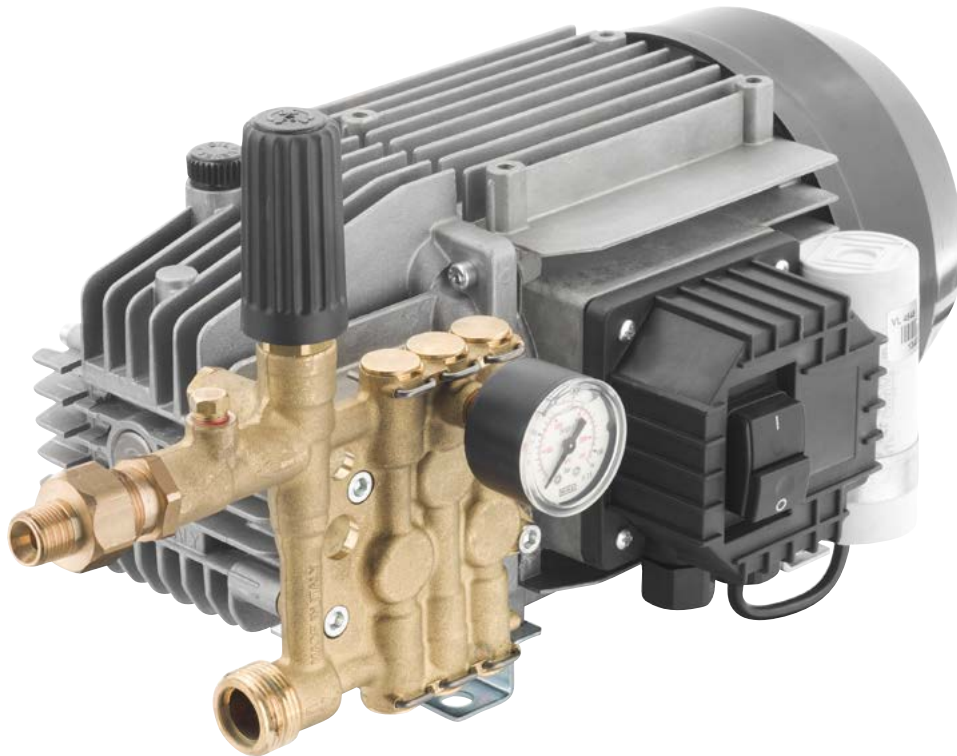

Corpo in lega di alluminio ad alta resistenza.

Crankcase in high-strength aluminium alloy.

Testa in ottone o alluminio.

Pump head in brass or aluminium.



idropultrici
pressure
washers

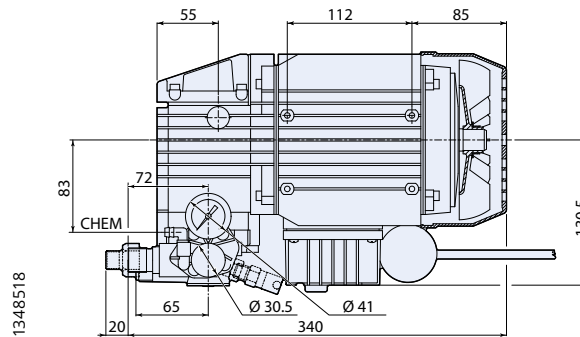
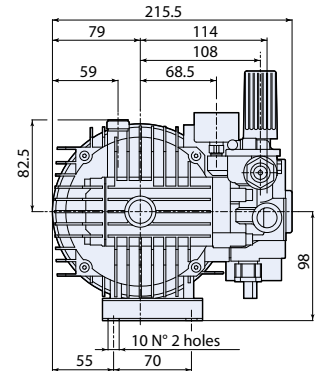
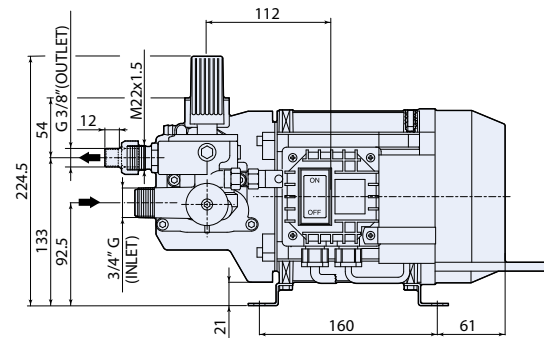
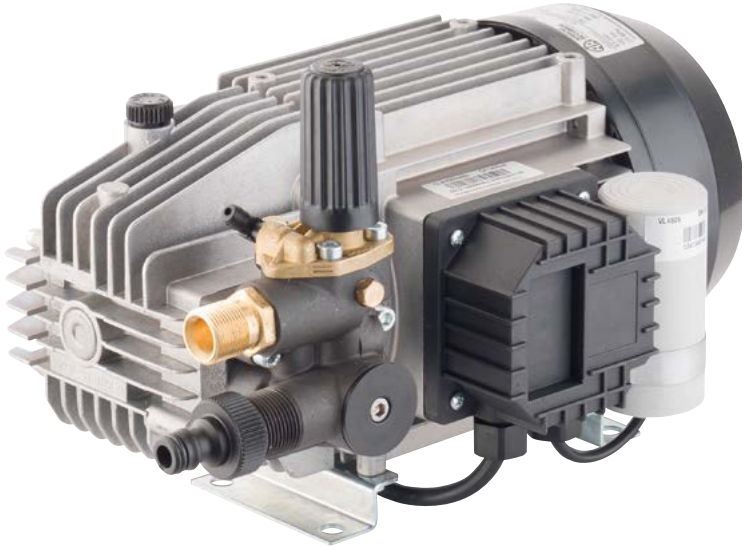

Manometro e interruttore forniti a richiesta.
Pressure gauge and switch on request.

MOD	COD	MAX	MAX							
	1 ~	l/min	gpm	bar	psi	hp	kW	N° giri/1'	V	kg
HPV 2800rpm										
HPV 8.11 EM	20463	8,5	2,25	100	1450	2	1,5	2800	230 ^a	13,8
HPV 11.07 EM	9253	11	2,90	70	1000	1,8	1,3	2800	230 ^a	13,8
HPV 1750rpm										
HPV 2G15 EM	9256	8	2,11	100	1450	2	1,5	1750	115 ^b	14

a) 1~ 50 Hz
b) 1~ 60 Hz



frequenza motore
motor frequency



frequenza motore
motor frequency



testa in alluminio
aluminium head



Additional Electric Motor

ELECTRIC MOTOR-PUMP UNITS



idropultrici
pressure
washers

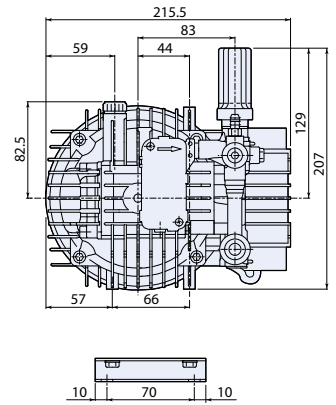
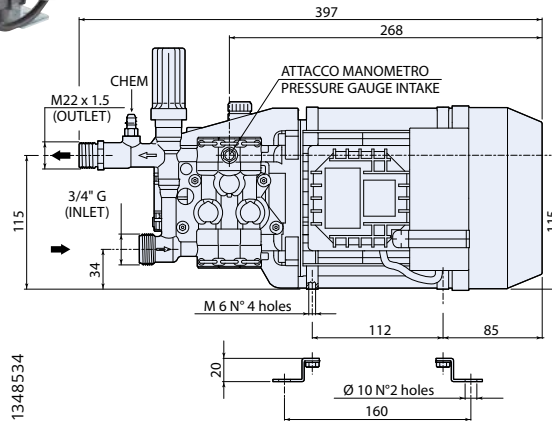
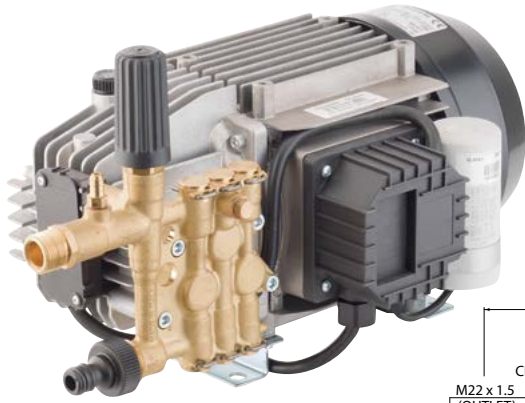

1348534

MOD	COD	MAX	MAX	MAX	MAX	hp	kW	N° giri/1'	V 1-50Hz	KG NET
	1 ~	l/min	gpm	bar	psi	hp	kW	N° giri/1'	V 1-50Hz	kg
HPV-O 2800rpm										
HPV-O 8.13 TSS EM	23851	8	2,11	130	1900	2,5	2	2800	230	15
HPV-O 8.15 TSS EM	25047	8	2,11	150	2200	3	2,2	2800	230	17
HPV-O 11.09 TSS EM	23906	11	2,90	90	1300	2,5	2	2800	230	15



testa in
ottone
brass
head



frequenza
motore
motor
frequency



ELECTRIC MOTOR-PUMP UNITS



misting

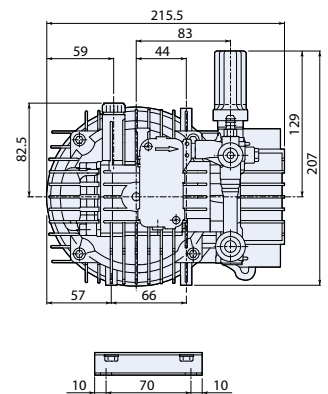
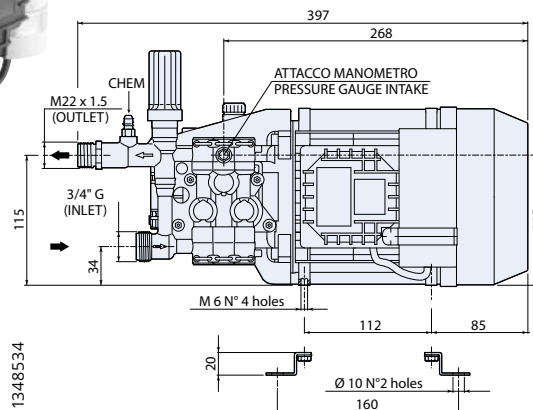
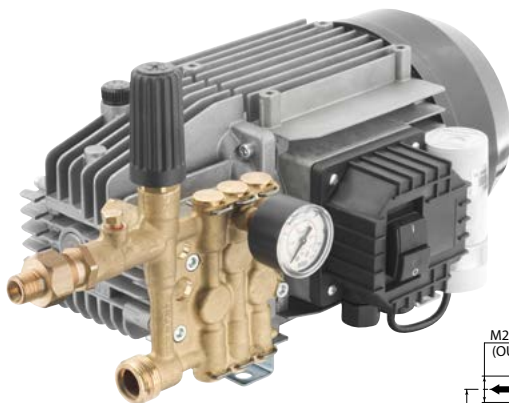

1348534

MOD	COD	MAX	MAX	MAX	MAX	hp	kW	N° giri/1'	V 1-50Hz	KG NET
	1 ~	l/min	gpm	bar	psi	hp	kW	N° giri/1'	V 1-50Hz	kg
HPV-MO 1450rpm										
HPV-MO 1,3.10 EM	23907	1,3	0,34	100	1450	0,8	0,6	1450	230	14,5



testa in
ottone
brass
head



frequenza
motore
motor
frequency



idropultrici
pressure
washers

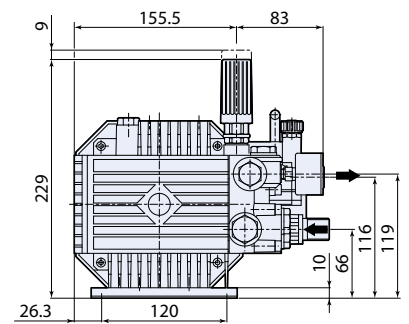
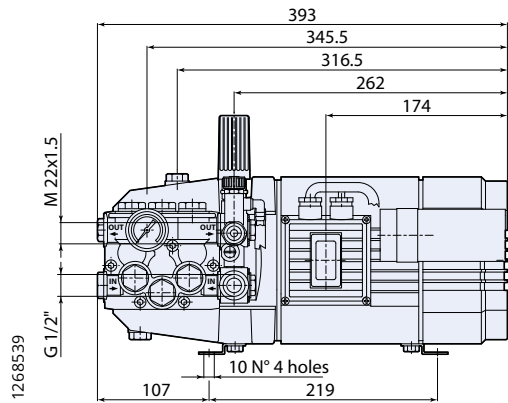

Valvole di regolazione a richiesta.
Regulating valve on request.
Manometro fornito a richiesta.
Pressure gauge on request.

MOD	COD.	MAX		MAX						KG	
		l/min	gpm	bar	psi	hp	kW	N° giri/1'	V 1-50Hz	V 3-50Hz	kg
HPE 1450 rpm											
HPE 8.14 ET	8598	8	2,11	140	2000	3	2,2	1450	-	230/400	22,5
HPE 9.14 ET	8502	9	2,37	140	2000	3	2,2	1450	-	230/400	22,5

Fuori produzione da gennaio 2025 - nuove unità HRC in arrivo
Out of production starting from 2025 - new HRC units will be coming soon



testa in
ottone
brass
head



bielle in
bronzo
bronze
connecting-rods



frequenza
motore
motor
frequency



COMING SOON



Additional Electric Motor

ELECTRIC MOTOR-PUMP UNITS



idropulitrici
pressure
washers

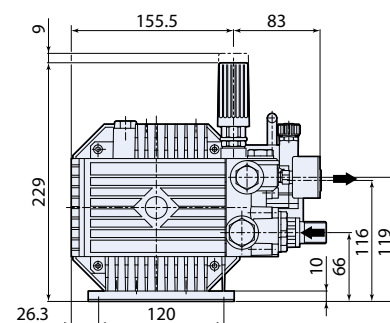
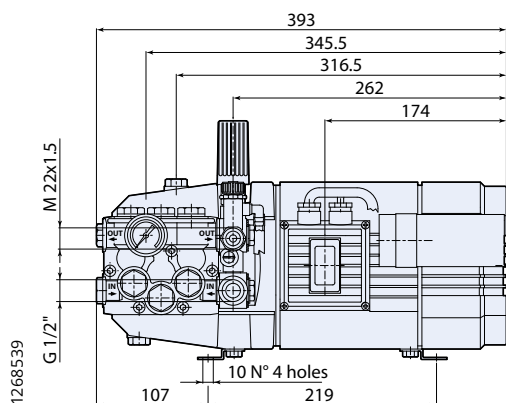

Valvole di regolazione a richiesta.
Regulating valve on request.
Manometro fornito a richiesta.
Pressure gauge on request.

MOD	COD	MAX	MAX								
	1 ~	l/min	gpm	bar	psi	hp	kW	N° giri/1'	V	1-60Hz	kg
HPE 1750rpm											
HPE 2G18 EM	8525	8	2,11	120	1740	2,5	1,8	1750	230		21,5



testa in
ottone
brass
head



bielle in
alluminio
aluminium
connecting-rods



1~60Hz
frequenza
motore
motor
frequency

Fuori produzione da gennaio 2025 - nuove unità HRC in arrivo
Out of production starting from 2025 - new HRC units will be coming soon



COMING SOON

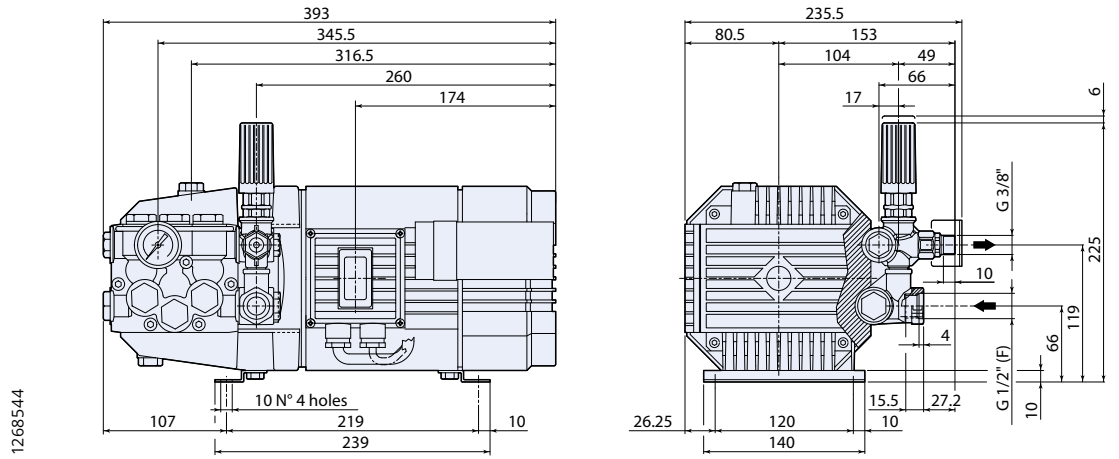

1268544

MOD	COD	MAX	MAX							
	1 ~	l/min	gpm	bar	psi	hp	kW	N° giri/1'	V 1-50Hz	kg
HPE-M 1450rpm										
HPE-M 02.08 EM	22096	2	0,52	80	1145	0,5	0,35	1450	230	22
HPE-M 04.08 EM	22097	4	1,06	80	1145	1	0,7	1450	230	22
HPE-M 06.08 EM	22838	6	1,58	80	1145	1	0,7	1450	230	22
HPE-M 08.08 EM	22098	8	2,11	80	1145	1,8	1,35	1450	230	22
HPE-M 11.07 EM	22895	11	2,90	70	1015	2,2	1,65	1450	230	22
HPE-M 13.06 EM	22896	13	3,43	60	870	2,2	1,65	1450	230	22



testa in ottone
brass head



bielle in bronzo
bronze connecting-rods



frequenza motore
motor frequency

Fuori produzione da gennaio 2025 - nuove unità HRC-M in arrivo
Out of production starting from 2025 - new HRC-M units will be coming soon



COMING SOON

WOBBLE PLATE

RPV
RPW
RMV
RMW
RQV
RQW

RXV
XJS
SJS
SJV
XJS+F39
HYD-XJS

HRM-O
HRM-MO
HPJ

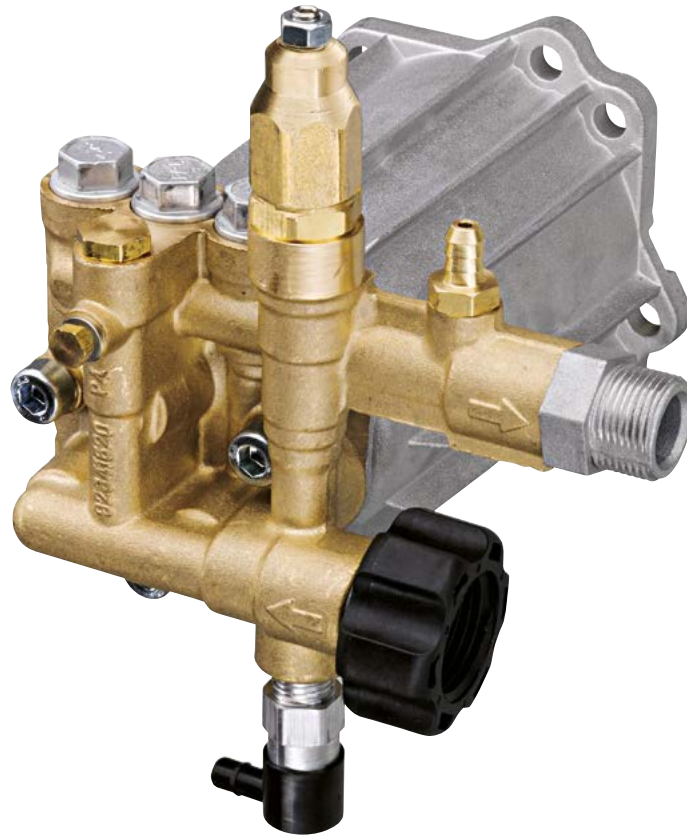

Corpo in lega di alluminio ad alta resistenza.

Crankcase in high-strength aluminium alloy.

Piattello oscillante in lega di alluminio con trattamento antiusura.

Wobble plate in aluminium alloy with a special wear-resistant coating.

Testa in ottone o alluminio.

Pump head in brass or aluminium.

Wobble Plate

POMPA ALBERO CAVO Hollow shaft pump



idropultrici
pressure
washers

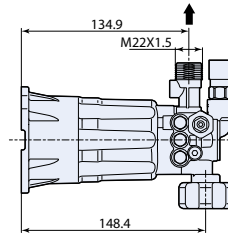
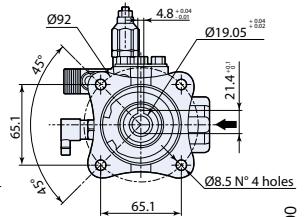
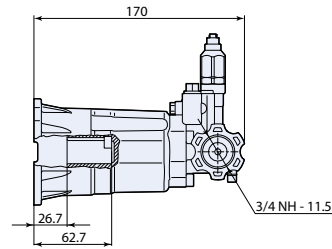
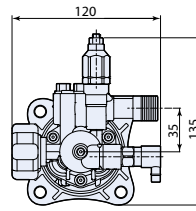

3828500

D version

MOD	COD	MAX	MAX		NET						
		l/min	gpm	bar	psi	hp	kW	N° giri/1'	kg		
RPV 3400rpm	Dversion Ø 3/4"										
RPV 2G19 D	24965	7,6	2	130	1900	2,7	2	3400	2,5		



testa in
alluminio
aluminium
head

Per motori scoppio
flangia Ø 3/4" SAE
J609a.
For gasoline engine flange
Ø 3/4" SAE J609a.



POMPA ALBERO CAVO Hollow shaft pump



idropultrici
pressure
washers

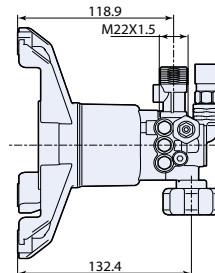
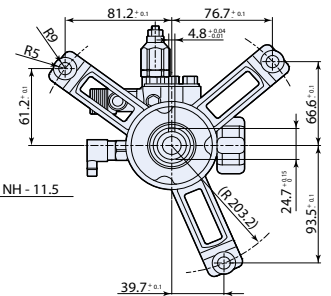
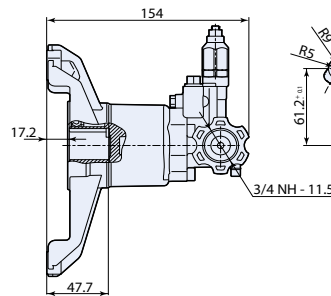
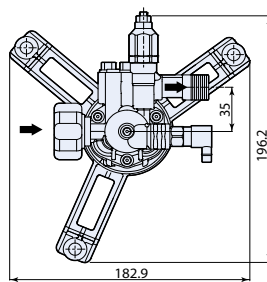

3828501

D version

MOD	COD	MAX	MAX		NET						
		l/min	gpm	bar	psi	hp	kW	N° giri/1'	kg		
RPW 3400rpm	Dversion Ø 7/8"										
RPW 2G19 D	24966	7,6	2	130	1900	2,7	2	3400	2,5		



testa in
alluminio
aluminium
head

Impiego con motori scoppio ad albero verticale.
For direct coupling to vertical engine.

Wobble Plate

POMPA ALBERO CAVO
Hollow shaft pump



idropultrici
pressure
washers

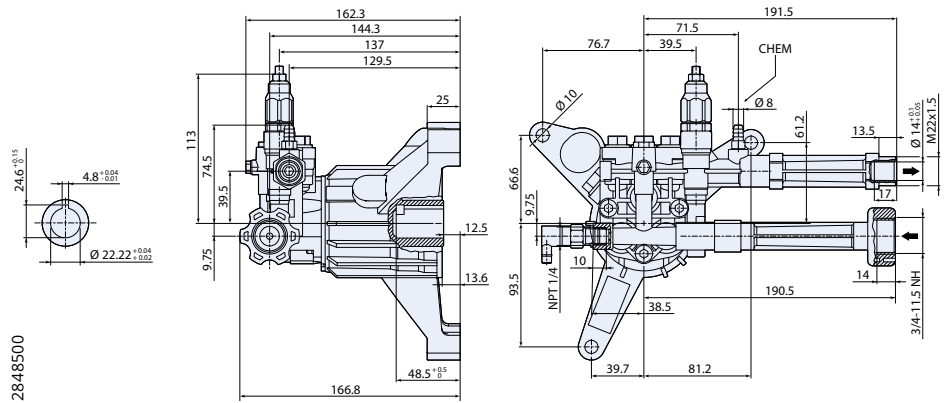
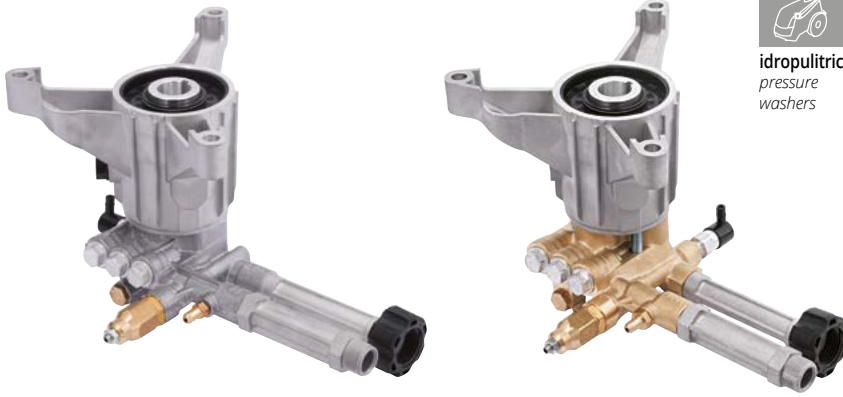

2848500

D version

MOD	COD	MAX	MAX			N° giri/1'		NET	
		l/min	gpm	bar	psi	hp	kW	kg	
RMW 3400rpm Dversion Ø 7/8"									
RMW 2G20 D	25110	7,6	2	140	2000	2,9	2,2	3400	3
RMW 2.2G24 D	24748	8,3	2,2	165	2400	3,8	2,8	3400	3
● RMW 2G23 D	25111	7,6	2	160	2300	3,4	2,5	3400	4,5
● RMW 2.5G26 D	25112	9,5	2,5	180	2600	4,8	3,6	3400	4,5
● RMW 2.5G28 D	24464	9,5	2,5	190	2800	5,1	3,8	3400	4,5

Impiego con motori scoppio ad albero verticale.
For direct coupling to vertical engine.



● testa in
ottone
brass
head



testa in
alluminio
aluminium
head



Wobble Plate

POMPA ALBERO CAVO Hollow shaft pump



idropultrici
pressure
washers

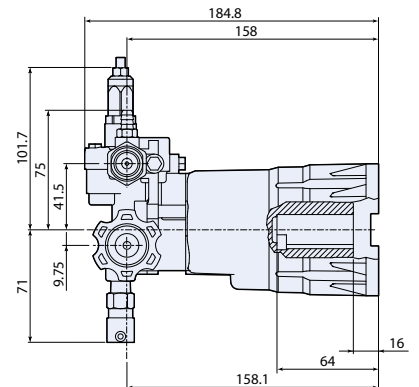
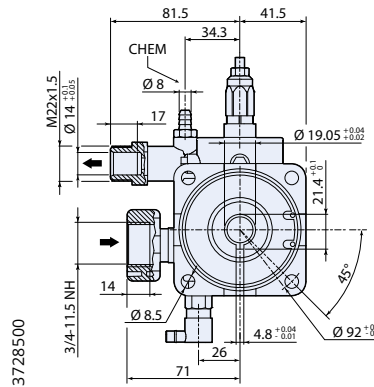

D version

MOD	COD	MAX	MAX						
		l/min	gpm	bar	psi	hp	kW	N° giri/1'	kg

RQV 3400rpm Dversion Ø 3/4"

RQV 2.5G30 D **25024** 9,5 2,5 205 3000 5,5 4 3400 3,5

Per motori scoppio flangia Ø 3/4" SAE J609a.
For gasoline engine flange Ø 3/4" SAE J609a.



testa in
ottone
brass
head

POMPA ALBERO CAVO Hollow shaft pump



idropultrici
pressure
washers

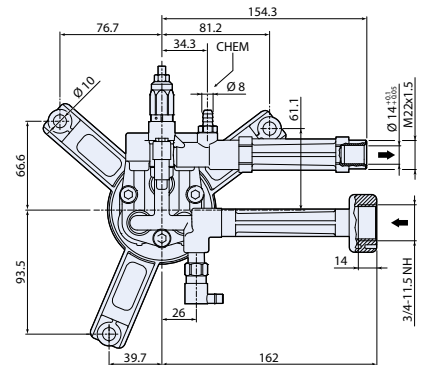
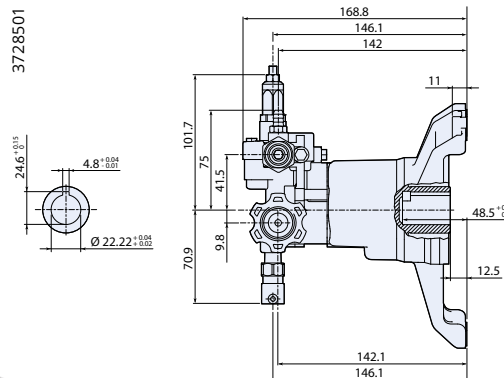
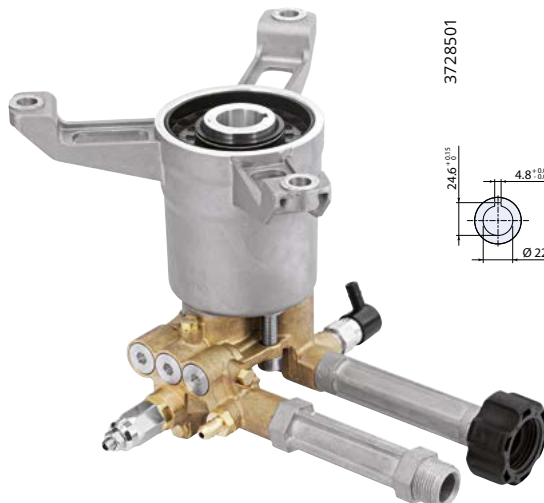

D version

MOD	COD	MAX	MAX						
		l/min	gpm	bar	psi	hp	kW	N° giri/1'	kg

RQW 3400rpm Dversion Ø 7/8"

RQW 2.5G28 D **25025** 9,5 2,5 190 2800 5,1 3,8 3400 3,5

Impiego con motori scoppio ad albero verticale.
For direct coupling to vertical engine.



testa in
ottone
brass
head

Wobble Plate

POMPA ALBERO CAVO
Hollow shaft pump



idropultrici
pressure
washers

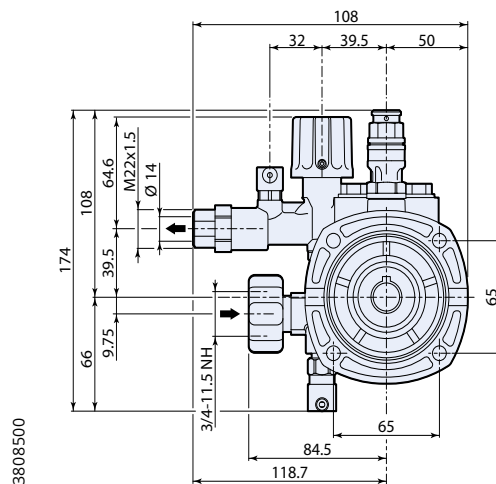



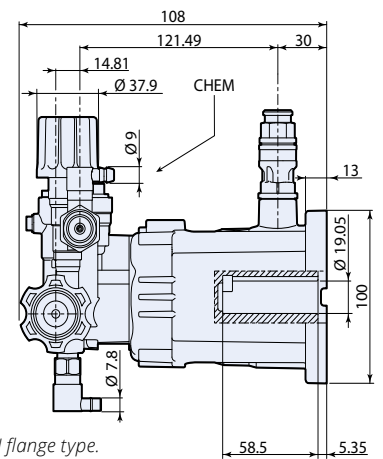

3808500



XT N flange type.

D version

MOD	COD	 MAX	 MAX						
		l/min	gpm	bar	psi	hp	kW	N° giri/1'	kg
RXV 3400rpm Dversion Ø 3/4"									
RXV 3G30 D	24918	11,4	3	205	3000	5,5	4	3400	4
RXV 3.5G30 D	24919	13,2	3,5	205	3000	7	5,2	3400	4

Per motori scoppio flangia Ø 3/4" SAE J609a.
For gasoline engine flange Ø 3/4" SAE J609a.



testa in
ottone
brass
head

Wobble Plate

POMPA ALBERO CAVO Hollow shaft pump





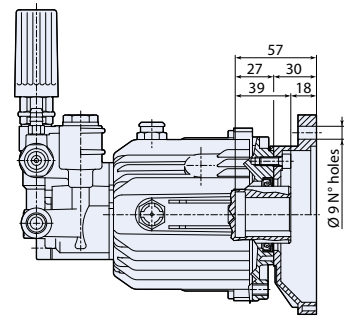
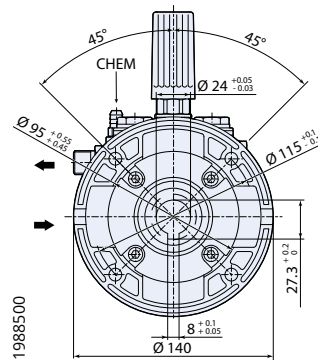

idropultrici
pressure
washers



Flangia F6 fornita a richiesta.
F6 flange on request.

C version

MOD	COD	 MAX	 MAX						
		l/min	gpm	bar	psi	hp	kW	N° giri/1'	kg
XJS 2800rpm Cversion Ø 24mm									
XJS 8.15 C	20484	8	2,11	150	2200	3	2,2	2800	5
XJS 10.15 C	20441	10	2,64	150	2200	4	3	2800	5
XJS 11.14 C	20442	11	2,90	140	2000	4	3	2800	5



testa in
ottone
brass
head

Flangia F6, per motori elettrici B14 Gr.90 IEC34-7, 2 poli 50Hz. Flangia non inclusa.
F6 flange for electric motor B14 90 IEC34-7, 2 poles 50Hz. Flange not included.







POMPA ALBERO CAVO Hollow shaft pump

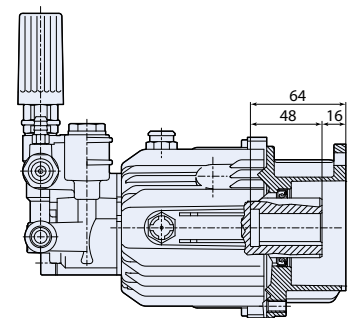
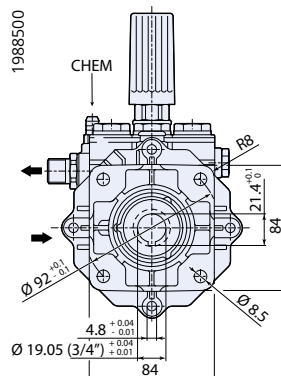

idropultrici
pressure
washers



D version + F7

MOD	COD	 MAX	 MAX						
		l/min	gpm	bar	psi	hp	kW	N° giri/1'	kg
SJV 3400rpm Dversion + F7 Ø 3/4"									
SJV 2G25 D + F7	21663	7,6	2	170	2500	3,5	2,6	3400	4,7
SJV 2.5G25 D + F7	21664	9,5	2,5	170	2500	4,5	3,3	3400	4,7
SJV 3G27 D + F7	21666	11,4	3	186	2700	5,5	4	3400	4,7
SJV 3.5G25 D + F7	21667	13,2	3,5	170	2500	6	4,4	3400	4,7



testa in
ottone
brass
head

Per motori scoppio flangia Ø 3/4" SAE J609a. Flangia inclusa.
For gasoline engine flange Ø 3/4" SAE J609a. Flange included.

Wobble Plate

ELECTRIC MOTOR-PUMP UNITS



misting

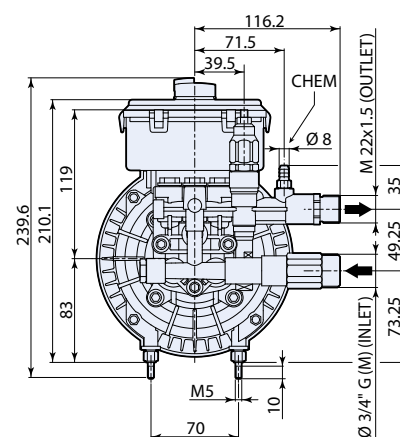
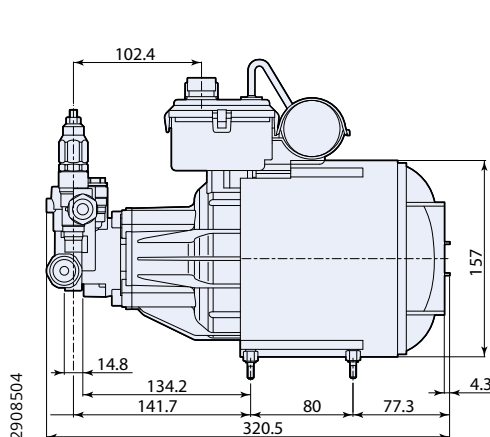

MOD	COD	1 ~	MAX	MAX						
		l/min	gpm	bar	psi	hp	kW	N° giri/1'	V 1-50Hz	kg
HRM-MO 1450rpm										
HRM-MO 0,5.08 EM	24753	0,5	0,13	80	1145	0,15	0,1	1450	230	15
HRM-MO 01.08 EM	22627	1	0,26	80	1145	0,3	0,2	1450	230	15,5
HRM-MO 02.08 EM	22628	2	0,52	80	1145	0,5	0,4	1450	230	15,5
HRM-MO 04.08 EM	22629	4	1,06	80	1145	1	0,8	1450	230	15,5

Disponibile anche la versione 115 Volt / 60 Hz.
115 Volt / 60 Hz version available.



testa in
ottone
brass
head



frequenza
motore
motor
frequency



Wobble Plate

ELECTRIC MOTOR-PUMP UNITS



idropulitrici
pressure
washers



TSS/REG model

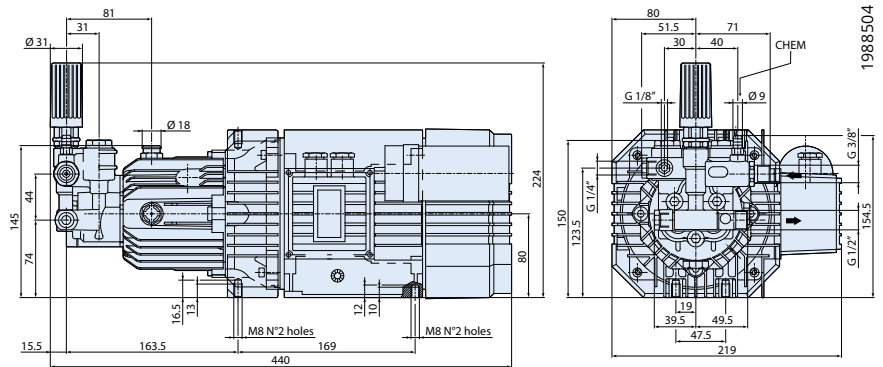

MOD	COD		MAX		MAX		V		kg NET			
	1~	3~	l/min	gpm	bar	psi	hp	kW				
HPJ 2800rpm												
HPJ 8.12 REG EM	20415	-	8	2,11	120	1740	2,5	1,8	2800	230	-	20,4
HPJ 8.12 TSS/REG EM	20994	-	8	2,11	120	1740	2,5	1,8	2800	230	-	20,4
HPJ 8.15 REG EM	20416	-	8	2,11	150	2200	3	2,2	2800	230	-	21
HPJ 8.15 TSS/REG EM	20995	-	8	2,11	150	2200	3	2,2	2800	230	-	21
HPJ 10.12 REG EM	20417	-	10	2,64	120	1740	3	2,2	2800	230	-	21
HPJ 10.12 TSS/REG EM	20996	-	10	2,64	120	1740	3	2,2	2800	230	-	21
HPJ 10.15 REG ET	-	20418	10	2,64	150	2200	4	3	2800	-	380	21,3
HPJ 10.15 TSS/REG ET	-	21073	10	2,64	150	2200	4	3	2800	-	380	21,3
HPJ 11.11 REG EM	20419	-	11	2,90	110	1600	3	2,2	2800	230	-	21
HPJ 11.11 TSS/REG EM	20997	-	11	2,90	120	1740	3	2,2	2800	230	-	21
HPJ 11.14 REG ET	-	20420	11	2,90	140	2000	4	3	2800	-	380	21,3

Disponibili anche le versione 60 Hz, previa verifica tecnica.
60 Hz versions available upon technical verification.



testa in
ottone
brass
head



frequenza
motore
motor
frequency



frequenza
motore
motor
frequency

Wobble Plate

HYDRAULIC DRIVE



municipality

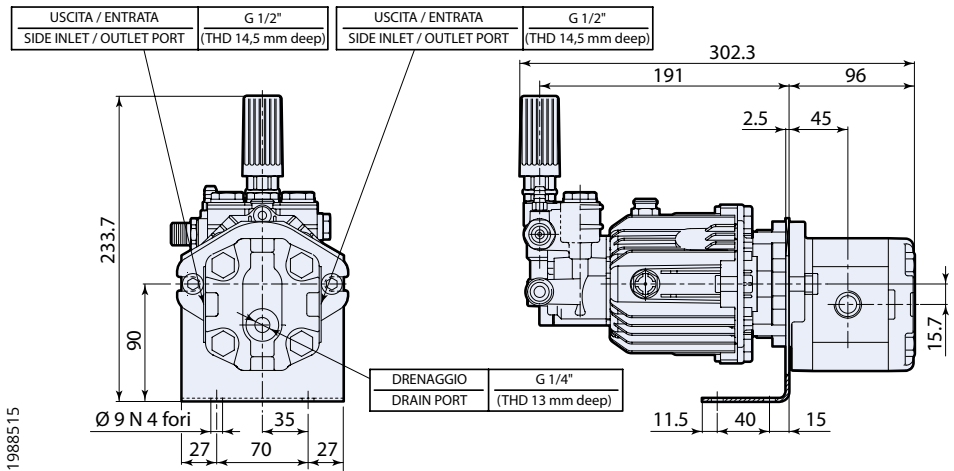

testa in ottone
brass head

motore idraulico
hydraulic drive

HYD - XJS

MOD	COD	POMPA A PISTONI • HP PISTON PUMP				MOTORE IDRAULICO • HYDRAULIC MOTOR				KG NET				
		MAX	MAX	RPM	⚡	SAUER DANFOSS	MAX	MAX	RPM					
		l/min	gpm	bar	psi	N° giri/1'	hp	Type	Cod	cm ³	bar	l/min	N° giri/1'	kg
HYD-XJS														
HYD XJS 11.14	21602	11	2,90	140	2000	2800	4	SNM2NN/8,0BN06 GAM1F4F4N	4768	8,4	123	24,5	2800	7,5

HYDRAULIC DRIVE



municipality

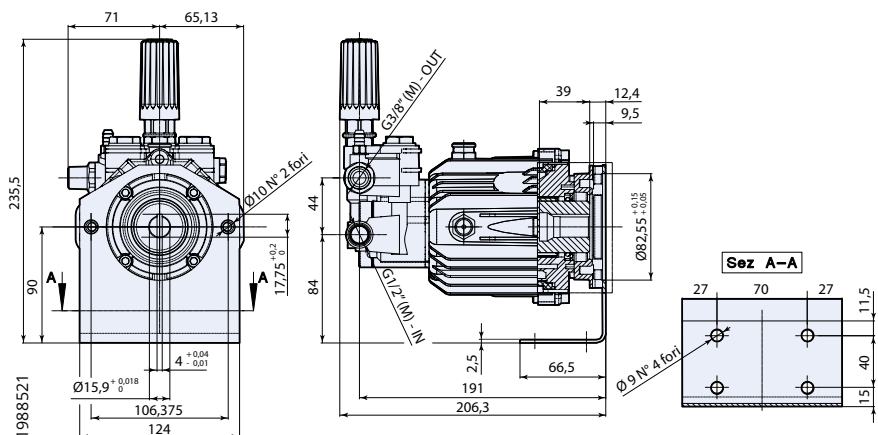

XJS + F39

MOD	COD	MAX	MAX	⚡	KG NET				
		l/min	gpm			bar	psi	hp	kW
XJS 2800rpm + F 39									
XJS 11.14 + F39	21597	11	2,90	140	2000	4	3	2800	5,5



testa in ottone
brass head

ACCESSORI

Accessories

Valvole di Regolazione

(Regulation Valves)

VRZ TSS + ID



Valvola di regolazione con ritorno automatico della pompa a 0 bar alla chiusura, by-pass con sistema di arresto totale a distanza.
Pressure regulating unloader valve, automatically relieves pressure from pump at shut-off, built-in by-pass and remote control for total shutdown.

INLET: 1/2" G (F), OUTLET: 3/8" G (M)

For RC, XM, RK series

COD.24324

Max 200 bar, 15 l/min

TSS®
Total Stop
SYSTEM

VRZ + ID, IDR

Valvola di regolazione con ritorno automatico della pompa a 0 bar alla chiusura, by-pass.

Pressure regulating unloader valve automatically relieves pressure from pump at shut-off, built-in by-pass.

INLET: 1/2" G (F), OUTLET: 3/8" G (M)

For RC, XM, RK series

COD.24669

Max 250 bar, 21 l/min



Con iniettore detergente.
With detergent injector.

COD.24591

Max 250 bar, 8÷15 l/min

COD.24670

Max 250 bar, 15,1÷21 l/min



Con iniettore detergente regolabile.
With adjustable detergent injector.

COD.24671

Max 250 bar, 8÷15 l/min

COD.24672

Max 250 bar, 15,1÷21 l/min



VRC-A

Valvola di regolazione con ritorno automatico della pompa a 0 bar alla chiusura.

Pressure regulating unloader valve, automatically relieves pressure from pump at shut-off.

For RC series

COD.23500

Max 180 bar, 18 l/min

INLET: 3/8" G (F), OUTLET: 3/8" G (M)

BY-PASS: 3/8" G (F)



For RC series

Con iniettore detergente

With detergent injector

COD.23501

Max 180 bar, ID, 15 l/min (*)

INLET: 3/8" G (F), OUTLET: 3/8" G (M)

BY-PASS: 3/8" G (F)



VRC-AM

Valvola di regolazione con ritorno automatico della pompa a 0 bar alla chiusura.

Pressure regulating unloader valve, automatically relieves pressure from pump at shut-off.

For RC series

COD.23502

Max 180 bar, 18 l/min

INLET: 3/8" G (F), OUTLET: 3/8" G (M)

BY-PASS: 3/8" G (F)



For RC series

Con iniettore detergente.

With detergent injector.

COD.23503

Max 180 bar, ID, 15 l/min (*)

INLET: 3/8" G (F), OUTLET: 3/8" G (M)

BY-PASS: 3/8" G (F)

* Su richiesta versione 18 l/min

On request 18 l/min version



VRC-BM

Valvola di regolazione con ritorno automatico della pompa a 0 bar alla chiusura.

Pressure regulating unloader valve, automatically relieves pressure from pump at shut-off.

For XT, RC, XM, RR

Con iniettore detergente.

With detergent injector.

COD.23505

Max 180 bar, 15 l/min (*)

INLET: 3/8" G (F), OUTLET: 3/8" G (M)

For XT, RC, XM, RR

Con iniettore detergente regolabile.

With adjustable detergent injector.

COD.23506

Max 180 bar, IDR, 15 l/min (*)

INLET: 3/8" G (F), OUTLET: 3/8" G (M)

* Su richiesta versione 18 l/min

On request 18 l/min version



MINIMATIC 4/B, + ID, IDR

Valvola di regolazione con ritorno automatico della pompa a 0 bar alla chiusura, by-pass.

Pressure regulating unloader valve automatically relieves pressure from pump at shut-off, built-in by-pass.

INLET: 1/2" G (F), OUTLET: 3/8" G (M)

For HPE, XT, RC, XM, RR, RK series

COD.20821

Max 180 bar, 18 l/min



Con iniettore detergente

With detergent injector

COD.20888

Max 180 bar, 7÷10 l/min (Ø2,0)

COD.20889

Max 180 bar, 10,1÷18 l/min (Ø2,3)



Con iniettore detergente regolabile.

With adjustable detergent injector.

COD.20890

Max 180 bar, 7÷10 l/min (Ø2,0)

COD.20891

Max 180 bar, 10,1÷18 l/min (Ø2,3)



MINIMATIC 4/B TSS, + ID, IDR

TSS®
Total Stop
SYSTEM

Valvola di regolazione con ritorno automatico della pompa a 0 bar alla chiusura, by-pass con sistema di arresto totale a distanza (patented).

Pressure regulating unloader valve, automatically relieves pressure from pump at shut-off, built-in by-pass and remote control for total shutdown (patented).

INLET: 1/2" G (F), OUTLET: 3/8" G (M)

For XT, RC, XM, RR, RK

COD. 25395

Max 180 bar, 18 l/min



For XT, XM, RR, RK

Con iniettore detergente con sistema di arresto totale a distanza (patented).

With detergent injector and remote control for total shutdown (patented).

COD. 25396

Max 180 bar, 7÷10 l/min (Ø2,0)

COD. 25397

Max 180 bar, 10,1÷18 l/min (Ø2,3)



For XT, XM, RR, RK

Con iniettore detergente regolabile con sistema di arresto totale a distanza (patented).

With adjustable detergent injector and remote control for total shutdown (patented).

COD. 22562

Max 180 bar, 7÷10 l/min (Ø2,0)

COD. 25398

Max 180 bar, 10,1÷18 l/min (Ø2,3)



Valvole di Regolazione

(Regulation Valves)

GYMATIC 3/A, + ID, IDR

Valvola di regolazione con ritorno automatico della pompa a 0 bar alla chiusura.

Pressure regulating unloader valve, automatically relieves pressure from pump at shut-off.

INLET, OUTLET, BY-PASS: 3/8" G (M)

For XM, RR, JK, RK, RW series

COD.20076

Max 250 bar, 35 l/min

Con iniettore detergente.

With detergent injector.

COD.20077

Max 250 bar, 11 l/min (Ø1,8)

COD.20078

Max 250 bar, 13÷18 l/min (Ø2,1)

COD.20079

Max 250 bar, 21 l/min (Ø2,3)

Con iniettore detergente regolabile.

With adjustable detergent injector.

COD.20396

Max 250 bar, 11 l/min (Ø1,8)

COD.20397

Max 250 bar, 13÷18 l/min (Ø2,1)

COD.20398

Max 250 bar, 21 l/min (Ø2,3)



GYMATIC 3/B, + ID, IDR

Valvola di regolazione con ritorno automatico della pompa a 0 bar alla chiusura, by-pass.

Pressure regulating unloader valve, automatically relieves pressure from pump at shut-off, built-in by-pass.

INLET: 1/2" G (F), OUTLET: 3/8" G (M)

For XM, RR, JK, RK series

COD.20080

Max 250 bar, 35 l/min

For JK, RK series

Con iniettore detergente.

With detergent injector.

COD.20081

Max 250 bar, 11 l/min (Ø1,8)

COD.20082

Max 250 bar, 13÷18 l/min (Ø2,1)

COD.20083

Max 250 bar, 21 l/min (Ø2,3)



For JK, RK series

Con iniettore detergente regolabile.

With adjustable detergent injector.

COD.20399

Max 250 bar, 11 l/min (Ø1,8)

COD.20400

Max 250 bar, 13÷18 l/min (Ø2,1)

COD.20401

Max 250 bar, 21 l/min (Ø2,3)

GYMATIC 3/B, + ID, IDR for XW

Valvola di regolazione con ritorno automatico della pompa a 0 bar alla chiusura, by-pass.

Pressure regulating unloader valve, automatically relieves pressure from pump at shut-off, built-in by-pass.

INLET: 3/4" G (F), OUTLET: 3/8" G (M)

For XW series

COD.20802

Max 250 bar, 35 l/min

For XW series

Con iniettore detergente.

With detergent injector.

COD.20759

Max 250 bar, 13÷18 l/min (Ø2,1)

COD.20760

Max 250 bar, 21 l/min (Ø2,3)



For XW series

Con iniettore detergente regolabile.

With adjustable detergent injector.

COD.20761

Max 250 bar, 13÷18 l/min (Ø2,1)

COD.20762

Max 250 bar, 21 l/min (Ø2,3)

VR 35

Valvola di regolazione con ritorno automatico della pompa a 0 bar alla chiusura.

Pressure regulating unloader valve, automatically relieves pressure from pump at shut-off.

INLET: 3/8" G (F), OUTLET: 3/8" G (M), BY-PASS: 3/8" G (F)

COD. 20831

Max 350 bar, 35 l/min



VR SS

Valvola di regolazione con corpo in acciaio e ritorno automatico della pompa a 0 bar alla chiusura.

Pressure regulating unloader valve with steel body, automatically relieves pressure from pump at shut-off.

INLET: 3/8" G (F), OUTLET: 3/8" G (M), BY-PASS: 3/8" G (F)

For Stainless Steel series

COD. 21350

Max 200 bar, 45 l/min



VR 3B for RK series

Valvola di regolazione con ritorno automatico della pompa a 0 bar alla chiusura, by-pass.

Pressure regulating unloader valve, automatically relieves pressure from pump at shut-off, built-in by-pass.

INLET: 1/2" G (F), OUTLET: 3/8" G (M)

For RK series

COD. 22308

Max 300 bar, 35 l/min



VR 3B for RG, RW series + ID, IDR

Valvola di regolazione con ritorno automatico della pompa a 0 bar alla chiusura, by-pass.

Pressure regulating unloader valve, automatically relieves pressure from pump at shut-off, built-in by-pass.

For RG, RW series

COD. 22621

Max 300 bar, 35 l/min

COD. 22622

Max 250 bar ID, 13-18 l/min, D 2,1

COD. 22623

Max 250 bar ID, 18-21 l/min, D 2,3

COD. 22624

Max 250 bar IDR, 13-18 l/min, D 2,1

COD. 22625

Max 250 bar IDR, 18-21 l/min, D 2,3

INLET: 1/2" G (F), OUTLET: 3/8" G (M)



VR 3B for XW series

Valvola di regolazione con ritorno automatico della pompa a 0 bar alla chiusura, by-pass.

Pressure regulating unloader valve, automatically relieves pressure from pump at shut-off, built-in by-pass.

For XW series

COD. 21839

Max 300 bar, 35 l/min

INLET: 1/2" G (F), OUTLET: 3/8" G (M)

COD. 21840

Max 300 bar, 35 l/min

INLET: 3/4" G (F), OUTLET: 3/8" G (M)



ZEROMATIC/93

Valvola di regolazione con ritorno automatico della pompa a 0 bar alla chiusura.

Pressure regulating unloader valve, automatically relieves pressure from pump at shut-off.

COD. 2907

Max 250 bar, 40 l/min

INLET: 1/2" G (F), OUTLET: 3/8" G (M),

BY-PASS: 1/2" G (F)

COD. 2908

Max 250 bar, 40 l/min

INLET: 1/2" NPT (F),

OUTLET: 3/8" NPT (M),

BY-PASS: 1/2" NPT (F)



ZEROMATIC/CSC

COD. 22789

Max 250 bar, 40 l/min

INLET: 1/2" G (F), OUTLET: 3/8" G (M),

BY-PASS: 1/2" G (F)

Per controllo statico circuiti idraulici.

For hydraulic circuit static check.



Valvole di Regolazione

(Regulation Valves)

GYMATIC 3/B, + ID, IDR



Valvola di regolazione nichelata con ritorno automatico della pompa a 0 bar alla chiusura, by-pass.
Nichel plated pressure regulating unloader valve, automatically relieves pressure from pump at shut-off, built-in by-pass.

INLET: 1/2" G (F), OUTLET: 3/8" G (M)

For XM, RR, JK, RK series

COD.28098

Max 250 bar, 35 l/min

VR 3B for RW series



Valvola di regolazione nichelata con ritorno automatico della pompa a 0 bar alla chiusura, by-pass.
Nichel plated pressure regulating unloader valve, automatically relieves pressure from pump at shut-off, built-in by-pass.

INLET: 1/2" G (F), OUTLET: 3/8" G (M)

For RW series

COD. 28099

Max 300 bar, 35 l/min

VR 3B for RK series



Valvola di regolazione nichelata con ritorno automatico della pompa a 0 bar alla chiusura, by-pass.
Nichel plated pressure regulating unloader valve, automatically relieves pressure from pump at shut-off, built-in by-pass.

INLET: 1/2" G (F), OUTLET: 3/8" G (M)

For RK series

COD. 28281

Max 300 bar, 35 l/min

VR 3B for XW series



Valvola di regolazione con ritorno automatico della pompa a 0 bar alla chiusura, by-pass.
Pressure regulating unloader valve, automatically relieves pressure from pump at shut-off, built-in by-pass.

INLET: 3/4" G (F), OUTLET: 3/8" G (M)

For XW-XWL series

COD. 28007

Max 300 bar, 35 l/min

VR 60



Valvola di regolazione nichelata con ritorno automatico della pompa a 0 bar alla chiusura, by-pass.
Nichel plated pressure regulating unloader valve, automatically relieves pressure from pump at shut-off, built-in by-pass.

INLET: 1/2" G (F), OUTLET: 1/2" G (F)

For SHP - RTX - RTD - RTP - RF - RGX

COD. 28067

Max 600 bar, 100 l/min

VRT 100



Valvola di regolazione con ritorno automatico della pompa a 0 bar alla chiusura.

Pressure regulating unloader valve, automatically relieves pressure from pump at shut-off.

INLET: 1/2" G (F), OUTLET: 1/2" G (F), BY-PASS: 1/2" G (F)

COD. 51591

Max 190 bar, 100 l/min

COD. 51960

Max 320 bar, 100 l/min

SVL 35



Valvola di sicurezza. Valvola compensata regolatrice di pressione. Regolarizza il bypass del fluido, con una minima variazione della pressione.
Safety valve. Compensated pressure regulating valve.

Regulates the bypass of the fluid with a minimum variation of the pressure.

INLET: 3/8" G (F), OUTLET: 3/8" G (F)

COD.52623

Max 310 bar, 40 l/min

SVL 20/250



Valvola di sicurezza. Valvola compensata regolatrice di pressione. Regolarizza il bypass del fluido, con una minima variazione della pressione.
Safety valve. Compensated pressure regulating valve.

Regulates the bypass of the fluid with a minimum variation of the pressure.

INLET: 3/4" G (F), OUTLET: 1/2" G (F)

COD. 52200

Max 200 bar, 250 l/min

VHP 39



Valvola di regolazione con ritorno automatico della pompa a 0 bar alla chiusura, by-pass.
Pressure regulating unloader valve, automatically relieves pressure from pump at shut-off, built-in by-pass.

INLET: 3/8" G (M), OUTLET: 3/8" G (F), BY-PASS: 2x3/8" G (F)

COD. 52593

Max 350 bar, 40 l/min

VHP 18/160



Valvola di regolazione con ritorno automatico della pompa a 0 bar alla chiusura, by-pass.
Pressure regulating unloader valve, automatically relieves pressure from pump at shut-off, built-in by-pass.

INLET: 3/4" G (F), OUTLET: 3/4" G (F), BY-PASS: 3/4" G (F)

COD. 52513

Max 160 bar, 160 l/min

VHP 31/250



Valvola di regolazione con ritorno automatico della pompa a 0 bar alla chiusura.

Pressure regulating unloader valve, automatically relieves pressure from pump at shut-off.

INLET: 1" G (F), OUTLET: 1" G (F) BY-PASS: 1" G (F)

COD. 51742

Max 150 bar, 250 l/min

COD. 51963

Max 280 bar, 250 l/min

Motori Idraulici

(Hydraulic Motors)

HM 44



Motore idraulico SAUER DANFOSS serie 3, 44 cc, flangia SAE B (2 fori), albero scanalato 13T
SAUER DANFOSS hydraulic motor series 3, 44 cc, flange SAE B (2 holes), splined shaft 13T

COD.45222

HM 90



Motore idraulico SAUER DANFOSS serie 3, 90 cc, flangia SAE B (2 fori), albero scanalato 13T
SAUER DANFOSS hydraulic motor series 3, 90 cc, flange SAE B (2 holes), splined shaft 13T

COD.45223

HM 34



Motore idraulico SUNFAB, 34 cc, flangia SAE B (2 fori), albero scanalato 13T
SUNFAB hydraulic motor, 34 cc, flange SAE B (2 holes), splined shaft 13T

COD.45221

HM 64



Motore idraulico OMF, 64 cc, flangia SAE B (2-4 fori), albero scanalato 13T
OMFB hydraulic motor, 64 cc, flange SAE B (2-4 holes), splined shaft 13T

COD.45230

HM 84



Motore idraulico SUNFAB, 84 cc, flangia SAE C (4 fori), albero scanalato 14T
SUNFAB hydraulic motor, 84 cc, flange SAE C (4 holes), splined shaft 14T

COD.45232

Flanges and Couplers

A » Z



F6

Flangia pompe serie XT, XJ, RC, C version per motori elettrici B3/B14 Gr.90.
Flange XT, XJ, RC series C version for close coupling B3/B14 90 frame.

COD.1581



F16

Flangia pompe serie XM, RK C version per motori elettrici B3/B14 Gr.100 e 112.
Flange XM, RK series C version for close coupling B3/B14 100 and 112 frame.

COD.1590



F41

Flangia pompe serie RK 'D' version per motori a scoppio con albero cilindrico 1" (25,4 mm) e flangia SAE J609a.
Flange RK series 'D' version for close coupling to gas/diesel engines with 1" cylindrical shaft and SAE J609a flange.

COD.1541



F7

Flangia pompe serie XT, XJ, RCV D version per motori a scoppio con albero cilindrico 3/4" (19,05 mm) e flangia SAE J609a.
Flange XT, XJ, RCV series D version for close coupling to gas/diesel engines with 3/4" cylindrical shaft and SAE J609a flange.

COD.1579



F17

Flangia pompe serie XM, RK E version per motori elettrici NEMA 182-184 (Ø 1" 1/8).
Flange XM, RK series E version for close coupling NEMA 182-184 (Ø1" 1/8 shaft).

COD.1591



F44

Flangia pompe serie RC C version per motori elettrici B3/B14 Gr.100.
Flange RC series C version for close coupling B3/B14 100 frame.

COD.41053



F8

Flangia pompe serie XT, XJ, RCA, RCV E version per motori elettrici NEMA 56-C.
Flange XT, XJ, RCA, RCV series E version for close coupling NEMA 56-C.

COD.1584



F25

Flangia pompe serie XM D version per motori a scoppio con albero cilindrico 3/4" (19,05 mm) e flangia SAE J609a.
Flange XM series D version for close coupling to gas/diesel engines with 3/4" cylindrical shaft and SAE J609a flange.

COD.1585



F45

Flangiatura con giunto elastico pompe serie RC per motori elettrici B3/B14 Gr. 90.
Bell housing + flexible coupling RC series for B3/B14 frame 90.

COD.1560



F10

Flangiatura con giunto rigido pompe serie XT, RC per motori elettrici B3/B14 Gr. 90.
Bell housing + solid coupling XT, RC series for B3/B14 frame 90.

COD.1582



F26

Flangiatura con giunto rigido pompe modelli RG, XW per motori idraulici tipo SAE J744 B101-2, B101-4. Albero Ø 25,4 mm (1").
Bell housing + solid coupling RG, XW models for hydraulic motors SAE J744 B101-2, B101-4 type. Shaft Ø 1" (25,4 mm).

COD.47810



F46

Flangiatura con giunto elastico pompe serie RC, RR per motori elettrici B3/B14 Gr. 100/112.
Bell housing + flexible coupling RC, RR series for B3/B14 frame 100/112.

COD.1566



F11

Flangiatura con giunto rigido pompe serie XT per motori elettrici B3/B14 Gr. 100.
Bell housing + solid coupling XT series for B3/B14 frame 100.

COD.1583



F28

Flangiatura con giunto elastico pompe serie JK, RG, RW, XW, XWL, SXW per motori elettrici B3/B14 Gr.100 e 112.
Bell housing + flexible coupling RG, RW, XW, XWL, SXW series for B3/B14 frame 100 and 112.

COD.1543



F50

Flangiatura con giunto elastico pompe modelli RTX per motori idraulici tipo SAE J744 B101-2, B101-4. Albero Ø 22,22 mm.
Bell housing + flexible coupling RTX models for hydraulic motors SAE J744 B101-2, B101-4 type. Shaft Ø 22.22 mm.

COD.41450



F13

Flangiatura con giunto elastico pompe serie XM, RK, RCW per motori elettrici B3/B14 Gr.100 e 112.
Bell housing + flexible coupling XM, RK, RCW series for B3/B14 frame 100 and 112.

COD.1587



F30

Flangiatura con giunto elastico pompe serie XM, RK, JK, RG, RW, XW, XWL, SXW per motori elettrici B3/B14 Gr.132-160S.
Bell housing + flexible coupling XM, RK, RG, RW, XW, XWL, SXW series for B3/B14 frame 132, 160S.

COD.1545



F51

Flangiatura con giunto elastico pompe modelli RTX per motori idraulici tipo SAE J744 B101-2, B101-4. Albero Ø 25,4 mm.
Bell housing + flexible coupling RTX models for hydraulic motors SAE J744 B101-2, B101-4 type. Shaft Ø 25.4 mm.

COD.41451



F14

Flangiatura con giunto elastico pompe serie XMA, RKA per motori elettrici NEMA 182-184 (albero Ø 1" 1/8).
Bell housing + flexible coupling XMA, RKA series for NEMA 182-184(Ø1" 1/8 shaft).

COD.1588



F32

Flangia pompe serie XM E version Ø 5/8" per motori elettrici NEMA 56-C.
Flange XM series E version Ø 5/8" for close coupling NEMA 56-C.

COD.1578



F52

Flangiatura con giunto elastico pompe modelli RTX per motori idraulici tipo SAE J744 B101-2, B101-4. Albero scanalato 15T.
Bell housing + flexible coupling RTX models for hydraulic motors SAE J744 B101-2, B101-4 type. Splined shaft 15T

COD.43780



F15

Flangiatura con giunto elastico pompe serie XMA, RKA per motori elettrici NEMA 213-215 (albero Ø 1" 3/8).
Bell housing + flexible coupling XMA, RKA series for NEMA 213-215 (Ø1" 3/8 shaft).

COD.1589



F40

Flangia pompe serie RS, XM 'D' version per motori a scoppio con albero cilindrico 1" (25,4 mm) e flangia SAE J609a.
Flange RS, XM series 'D' version for close coupling to gas/diesel engines with 1" cylindrical shaft and SAE J609a flange.

COD.1542



F53

Flangiatura con giunto elastico pompe modelli RTX per motori idraulici tipo SAE J744 B101-2, B101-4. Albero Ø 28,58 mm.
Bell housing + flexible coupling RTX models for hydraulic motors SAE J744 B101-2, B101-4 type. Shaft Ø 28.58 mm.

COD.43781

Flanges and Couplers

A » Z



F54

Flangiatura con giunto elastico pompe modelli RTX per motori idraulici tipo SAE J498 B101-2, B101-4. Albero scanalato 13T. *Bell housing + flexible coupling RTX models for hydraulic motors SAE J498 B101-2, B101-4 type. Splined shaft 13T.*

COD.46091



F55

Flangiatura con giunto elastico pompe modelli RTD per motori idraulici tipo SAE J744 C127-4. Albero Ø 31,75 mm. *Bell housing + flexible coupling RTD models for hydraulic motors SAE J744 C127-4 type. Shaft Ø 31.75 mm.*

COD.46120



F59

Flangiatura con giunto elastico pompe modelli RTD per motori idraulici tipo SAE J744 C-4. Albero scanalato 14T. *Bell housing + flexible coupling RTD models for hydraulic motors SAE J744 C-4 type. Splined shaft 14T.*

COD.46291



F60

Flangiatura con giunto elastico pompe modelli XW per motori idraulici tipo SAE J498 B101-2, B101-4. Albero scanalato 13T. *Bell housing + flexible coupling XW models for hydraulic motors SAE J498 B101-2, B101-4 type. Splined shaft 13T.*

COD.46513



F61

Flangiatura con giunto elastico pompe modelli XW per motori idraulici tipo SAE J744 B101-2, B101-4. Albero Ø 22,22 mm. *Bell housing + flexible coupling XW models for hydraulic motors SAE J744 B101-2, B101-4 type. Shaft Ø 22.22 mm.*

COD.46574



F62

Flangiatura con giunto rigido pompe modelli XW per motori idraulici tipo SAE J744 B101-2, B101-4. Albero scanalato 13T. *Bell housing + solid coupling XW models for hydraulic motors SAE J744 B101-2, B101-4 type. Splined shaft 13T.*

COD.46703

Lance

(Lances)

RE 70 • RE 90 • RE 120 • RE 150 • RE 170 • RE 200

Lancia. Lunghezza: • *Lance. Length:*
70 cm max 250 bar 40 l/min, 180° C.
INLET: 1/4" G (M), OUTLET: 1/4" NPT (F)
COD.3002

90 cm max 250 bar 40 l/min, 180° C.
INLET: 1/4" G (M), OUTLET: 1/4" NPT (F)
COD.3003

120 cm max 250 bar 40 l/min, 180° C.
INLET: 1/4" G (M), OUTLET: 1/4" NPT (F)
COD.3004

150 cm max 250 bar 40 l/min, 180° C.
INLET: 1/4" G (M), OUTLET: 1/4" NPT (F)
COD.3005

170 cm max 250 bar 40 l/min, 180° C.
INLET: 1/4" G (M), OUTLET: 1/4" NPT (F)
COD.3006

200 cm max 250 bar 40 l/min, 180° C.
INLET: 1/4" G (M), OUTLET: 1/4" NPT (F)
COD.3007

SANDJET PROF

Kit lancia sabbiante.
Complete sandblasting kit.

Ø1,2 (1/4" G) **COD.3695**

Ø1,4 (1/4" G) **COD.3696**

Ø1,2 (M22 x 1,5) **COD.3697**

Ø1,4 (M22 x 1,5) **COD.3698**

Ø1,8 (M22 x 1,5) **COD.3699**

ROTOPOWER PROF 2

Ugello rotante alta pressione.
High pressure rotating nozzle.
M22x1,5mm fitting.

TTR Ø 1,25 **COD.40167**

TTR Ø 1,35 **COD.40169**

TPR Ø 1,40 **COD.40168**

TPR Ø 1,50 **COD.40173**

REG SPRAY 5

Kit testina con ugelli Spraying System.
Head gun kit with Spraying System nozzle.
M22x1,5mm fitting.

1504 **COD.3615**

1505 **COD.41274**

1507 **COD.3617**

15025 **COD.3618**

15055 **COD.3704**

DRE 115

Doppia lancia. • *Double lance.*
Max 280 bar 40 l/min, 150°C.
INLET: 1/4" G (M), OUTLET: 1/4" NPT (F)
COD.41105

WASH SPRAY

Kit testina. • *Head gun kit.*
M22x1,5mm fitting.
Ø1,1 White/Bianco **COD.40112**
Ø1 Green/Verde **COD.40113**
Ø1,25 Orange/Arancio **COD.40039**

Pistole

(Spray Guns)

MV 925

Pistola automatica. • *Wash gun.*
Max 310 bar 30 l/min, 160°C
INLET: 3/8" G (F), OUTLET: 1/4" G (F)
COD.41837

ML 955

Pistola automatica. • *Wash gun.*
Max 350 bar 40 l/min, 160°C
INLET: 3/8" G (F) Swivel, OUTLET: 1/4" G (F)
COD.46141

AL 13 - 1/4"

Kit pistola per Wash Spray, Reg Spray 5, Rotopower Prof 2.
Gun kit for Wash Spray, Reg Spray 5, Rotopower Prof 2.
Max 255 bar 30 l/min, 60°C
INLET: 1/4" G (M),
OUTLET: M22x1,5mm (F)
COD.41046

AL 13 - 3/8"

Kit pistola per Wash Spray, Reg Spray 5, Rotopower Prof 2.
Gun kit for Wash Spray, Reg Spray 5, Rotopower Prof 2.
Max 225 bar 30 l/min, 60°C
INLET: 3/8" G (M)
OUTLET: M22x1,5mm (F)
COD.41045

Ugelli

(Nozzles)

WASH NOZZLES

Nozzle. • Ugello. 1/4 MEG 0°, 15°, 25°. Specificare nell'ordine il tipo di getto. (Vedi tabella pag. 174).
When ordering always state type of jet required. (See page 174).

(5)

UPT

Nozzle. • Ugello. 1/4 MEG 0°, 15°, 25°. Ugello pulizia tubazioni.
Pipe cleaning nozzle.
Max 120 bar 11 l/min, INLET: 1/4" G (M)
COD.1122190

PR

Portaugello regolabile.
Adjustable nozzle holder.
Max 250 bar 30 l/min, 150°C
INLET: 1/4" G (F), OUTLET: 1/4" NPT (F)
COD.3071

TDV

Testina doppio ugello. • *Roller nozzles.*
Max 200 bar 40 l/min, 90°C
INLET: 1/4" G (F),
OUTLET: 2x1/4" NPT (F)
COD.3025

Tubi Alta Pressione

(HP Hoses)



SAE 100 R1 (10m)

Tubo alta pressione Ø 5/16" con raccordi.

5/16" high pressure hose with couplings.
Raccordi/Couplings 3/8" G (M) - 3/8" G (F)

COD.3118

Raccordi/Couplings 3/8" G (F) - 3/8" G (F)
COD.3122



SAE 100 R1 (16m)

Tubo alta pressione m 16.

High pressure hose kit.

Length 16m / 52 ft.

Ø 5/16", M22X1,5(F) - 1/4"G(F)

COD.1271900



SAE 100 R2 (10m)

Tubo alta pressione Ø 3/8" con raccordi.
3/8" high pressure hose with couplings.

Raccordi/Couplings 3/8" G (M) - 3/8" G (F)

COD.3119

Raccordi/Couplings 3/8" G (F) - 3/8" G (F)
COD.3120



HP8 PROF

Kit tubo alta pressione m 8.

Per AR 13-1/4".

High pressure hose kit. Length 8m / 26 ft.

For AR 13-1/4".

Ø 5/16", max. 315 bar

COD.3725



HP8

Kit tubo termoplastico alta pressione, per AR 13-1/4".

Thermoplastic HP hose kit, for AR 13-1/4".

Ø 1/4" max.160 bar

COD.40102

Ø 5/16" max.160 bar

COD.40104

Riduttori

(Gear Boxes)



CR 3/4"

Riduttore 1:2 per motori a scoppio/diesel con albero cilindrico 3/4" (19,05 mm) e flangia SAE J609a.

1:2 reduction gear box for gas/diesel engines with 3/4" cylindrical shaft and SAE J609a flange.

XT series
COD.1694

XM, RK series
COD.1692

Riduttore 1:2,24 per motori a scoppio/diesel con albero cilindrico 3/4" (19,05 mm) e flangia SAE J609a.

1:2,24 reduction gear box for gas/diesel engines with 3/4" cylindrical shaft and SAE J609a flange.

XM, RK series
COD.1691



CR 1"

Riduttore 1:2 per motori a scoppio/diesel con albero cilindrico 1" (25,4 mm) e flangia SAE J609a.

1:2 reduction gear box for gas/diesel engines with 1" cylindrical shaft and SAE J609a flange.

XT series
COD.1693

XM, RK series
COD.1690
RG, RW, XW, SXW series
COD.1697

Riduttore 1:2,24 per motori a scoppio/diesel con albero cilindrico 1" (25,4 mm) e flangia SAE J609a.

1:2,24 reduction gear box for gas/diesel engines with 1" cylindrical shaft and SAE J609a flange.

XM, RK series
COD.1689
RG, RW, XW, SXW series
COD.1698



CR 1"1/8

Riduttore 1:2 per motori a scoppio/diesel con albero cilindrico 1" 1/8 (28,6 mm) e flangia SAE J609a.

1:2 reduction gear box for gas/diesel engines with 1" 1/8 cylindrical shaft and SAE J609a flange.

RG, RW, XW, SXW series
COD.1670



WG24

Utilizzabile con motori fino a 24HP.
For motors up to 24HP.

NEW

Riduttore 1:2,2 a denti elicoidali per motori a scoppio/diesel con albero cilindrico 1" (25,4 mm) e flangia SAE J609 fl.B - C.

1:2,2 reduction gear box with helical teeth for gas/diesel engines with 1" cylindrical shaft and SAE J609 B - C flanges.

RG, XW, series
COD.70078
XM, RK series
COD.70080

Riduttore 1:2 a denti elicoidali per motori a scoppio/diesel con albero cilindrico 1" (25,4 mm) e flangia SAE J609 fl.B - C.

1:2 reduction gear box with helical teeth for gas/diesel engines with 1" cylindrical shaft and SAE J609 B - C flanges.

RG, XW series
COD.70079
XM, RK series
COD.70081



WG31

Utilizzabile con motori fino a 31HP.
For motors up to 31HP.

NEW

Riduttore 1:2,2 a denti elicoidali per motori a scoppio/diesel con albero cilindrico 1" 1/8 (28,6 mm) e flangia SAE J609 fl.B - C.

1:2,2 reduction gear box with helical teeth for gas/diesel engines with 1" 1/8 cylindrical shaft and SAE J609 B - C flanges.

Riduttore 1:2 a denti elicoidali per motori a scoppio/diesel con albero cilindrico 1" 1/8 (28,6 mm) e flangia SAE J609 fl.B - C.

1:2 reduction gear box with helical teeth for gas/diesel engines with 1" 1/8 cylindrical shaft and SAE J609 B - C flanges.

RG, RW, XW, SXW series
COD.29593



WG40

Utilizzabile con motori fino a 40HP.
For motors up to 40HP.

NEW

Riduttore 1:2,25 a denti elicoidali per motori a scoppio/diesel con albero cilindrico 1" 1/8 (28,6 mm) e flangia SAE J609c.

1:2,25 reduction gear box with helical teeth for gas/diesel engines with 1" 1/8 cylindrical shaft and SAE J609c flange.

RTX, RF series
Motori HONDA/B&S / HONDA/B&S engines
COD.29403

RTX, RF series
Motori KOHLER / KOHLER engines
COD.29874

Riduttore 1:2,25 a denti elicoidali per motori a scoppio/diesel con albero cilindrico 1" 7/16 (36,5 mm).

1:2,25 reduction gear box with helical teeth for gas/diesel engines with 1" 7/16 cylindrical shaft.

RTX, RF series
Motori HONDA/B&S / HONDA/B&S engines
COD.29923

RTX, RF series
Motori KOHLER / KOHLER engines
COD.29924



WG75

Utilizzabile con motori fino a 75HP.
For motors up to 75HP

NEW

Riduttore 1:1,5 a denti elicoidali per motori a scoppio/diesel con albero maschio Ø40.

1:1,5 reduction gear box with helical teeth for gas/diesel engines with Ø40 male shaft.

RTD series
COD.28687

Riduttore 1:1,86 a denti elicoidali per motori a scoppio/diesel con albero maschio Ø40.

1:1,86 reduction gear box with helical teeth for gas/diesel engines with Ø40 male shaft.

RTD series
COD.28688

Riduttore 1:2,22 a denti elicoidali per motori a scoppio/diesel con albero maschio Ø40.

1:2,22 reduction gear box with helical teeth for gas/diesel engines with Ø40 male shaft.

RTD series
COD.28689

Other accessories

A » Z

FAS



Filtro aspirazione.
Suction strainer.

Max 10 bar, max 20 l/min.
INLET: 1/2" G (F), OUTLET: 1/2" G (M)
COD.3000



Filtro aspirazione.
Aluminium suction strainer.

Max 10 bar, max 20 l/min.
INLET: 1/2" G (F), OUTLET: 1/2" G (M)
COD.3121



Max 14 bar, max 80 l/min.
INLET: 3/4" G (F), OUTLET: 3/4" G (F)
COD.50031

FD



Filtro aspirazione detergente.
Detergent suction filter.
COD.1341030

FDR



Filtro aspirazione detergente con
valvola di non ritorno.
Detergent suction filter with check valve.
COD.3116

FS



Galleggiante.
Float.
Max 8 bar 21 l/min, 60° C.
INLET: Ø 27 mm
COD.3114

JETTER VALVE



Jetter valve.
XT, XM series **COD.40235**
RC series **COD.41003**
RK series **COD.40161**
XW series **COD.40236**
RTJ series **COD.43948**
RTX series **COD.43949**
RTF series **COD.46537**

IDF



Iniettore detergente fisso.
Detergent injector.

TYPE	INLET	OUTLET	CHEM Ø mm	COD.
1,8	3/8" G(F)	3/8" G(M)	8	3060
2,1	3/8" G(F)	3/8" G(M)	8	3061
2,3	3/8" G(F)	3/8" G(M)	8	3062
1,8	3/8" G(M)	3/8" G(M)	8	3033
2,1	3/8" G(M)	3/8" G(M)	8	3034

IDR



Iniettore detergente regolabile.
Adjustable detergent injector.

TYPE	INLET	OUTLET	CHEM Ø mm	COD.
1,8	3/8" G(F)	3/8" G(M)	8	3057
2,1	3/8" G(F)	3/8" G(M)	8	3058
2,3	3/8" G(F)	3/8" G(M)	8	3059
1,8	3/8" G(M)	3/8" G(M)	8	3035
2,1	3/8" G(M)	3/8" G(M)	8	3036

IR



Innesti rapidi. • *Quick couplings.*

TYPE	RING NUT	COUPLING Ø	COD.
IR 06	without/senza	3/8" G (F)	3044



IR 07	without/senza	1/4" G (F)	3045
-------	---------------	------------	-------------



IR 08	without/senza	3/8" G (M)	3046
-------	---------------	------------	-------------



IR 09	without/senza	1/4" G (M)	3047
-------	---------------	------------	-------------



Innesti rapidi. • *Quick couplings.*

TYPE	RING NUT	COUPLING Ø	COD.
IR 6	with/con	3/8" G (F)	3048
IR 7	with/con	1/4" G (F)	3049
IR 8	with/con	3/8" G (M)	3050
IR 9	with/con	1/4" G (M)	3051

MCS



Manometro.
Max 250 bar, attacco 1/4" G (M)
centrale posteriore, Ø 63 mm.

Pressure gauge.
Max 250 bar, 1/4" G (M) rear central
attachment, Ø 63 mm.

COD.3001

Max 315 bar, attacco 1/4" G (M)
centrale posteriore, Ø 63 mm.
Max 315 bar, 1/4" G (M) rear central
attachment, Ø 63 mm.

COD.41031

MH



Manometro.
Attacco 1/8" G (M) centrale posteriore,
Ø 40 mm.

Pressure gauge.
1/8" G (M) rear central attachment, Ø 40 mm.

COD.3223 Max 150 bar
COD.1271190 Max 250 bar



Max 315 bar, attacco 1/4" G (M)
centrale posteriore, Ø 50 mm.
Max 315 bar, 1/4" G (M) rear central
attachment, Ø 50 mm.

COD.1381580

MR



Manometro.
Max 250 bar, attacco 1/4" G (M)
laterale, Ø 63 mm.

Pressure gauge.
Max 250 bar, 1/4" G (M) bottom
attachment, Ø 63 mm.

COD.740260

Max 315 bar, 1/4" G (M) bottom
attachment, Ø 63 mm.
Max 315 bar, attacco 1/4" G (M) laterale,
Ø 63 mm.

COD.41032

PD



Accumulatore.
Pulsation dampener.

Max 250 bar, -15 +80 °C, INLET: 1/2"
G (F)

COD.50046

PX



Pressostato.
Pressure switch.

40-250 bar, 12-250 Vca, 15A, 90° C

COD.51368

KIT B



Piedi. • *Base.*

	COD.
XT, XTA	1836
XM, XMS, XMA, XHW	2729
RC, RCA, RCS, RR, RRA	42376
RK, RKA, RHW	2729
RG, RW, XW, XWA, SXW, WHW, WHWL, SHP, SHPA, RGX, RGXA, XWP	2748

KIT C



Kit C per XWT • *Kit C for XWT.*

COD.2519



Tabella portate teoriche con pressioni in bar, portate in L/min e Ø foro equivalente in mm
Theoretical flow chart with pressures in bar, flows in L/min and equivalent nozzle diameter in mm

Nozzle	OUTPUT IN L/1' AT THE INDICATED PRESSURE • PORTATE IN L/1' ALLE PRESSIONI INDICATE																				
Type MEG	Ø mm	20	30	40	50	60	70	80	90	100	110	120	130	140	150	160	170	180	190	200	210
..015	0,80	1,5	1,9	2,2	2,4	2,6	2,9	3,1	3,2	3,4	3,6	3,7	3,9	4,0	4,2	4,3	4,5	4,6	4,7	4,8	5,0
..02	0,91	2,0	2,5	2,9	3,2	3,5	3,8	4,1	4,3	4,6	4,8	5,0	5,2	5,4	5,6	5,8	5,9	6,1	6,3	6,4	6,6
..025	1,00	2,5	3,1	3,6	4,0	4,4	4,8	5,1	5,4	5,7	6,0	6,2	6,5	6,7	7,0	7,2	7,4	7,6	7,9	8,1	8,3
..03	1,09	3,1	3,7	4,3	4,8	5,3	5,7	6,1	6,5	6,8	7,2	7,5	7,8	8,1	8,4	8,6	8,9	9,2	9,4	9,7	9,9
..035	1,12	3,6	4,4	5,0	5,6	6,2	6,7	7,1	7,6	8,0	8,4	8,7	9,1	9,4	9,8	10,1	10,4	10,7	11,0	11,3	11,6
..04	1,19	4,1	5,0	5,8	6,4	7,1	7,6	8,2	8,6	9,1	9,6	10,0	10,4	10,8	11,2	11,5	11,9	12,2	12,6	12,9	13,2
..045	1,27	4,6	5,6	6,5	7,2	7,9	8,6	9,2	9,7	10,3	10,8	11,2	11,7	12,1	12,6	13,0	13,4	13,8	14,1	14,5	14,9
..05	1,35	5,1	6,2	7,2	8,1	8,8	9,5	10,2	10,8	11,4	11,9	12,5	13,0	13,5	14,0	14,4	14,9	15,3	15,7	16,1	16,5
..055	1,40	5,6	6,9	7,9	8,9	9,7	10,5	11,2	11,9	12,5	13,1	13,7	14,3	14,8	15,3	15,9	16,3	16,8	17,3	17,7	18,2
..06	1,47	6,1	7,5	8,6	9,7	10,6	11,4	12,2	13,0	13,7	14,3	15,0	15,6	16,2	16,7	17,3	17,8	18,3	18,8	19,3	19,8
..065	1,52	6,6	8,1	9,4	10,5	11,5	12,4	13,2	14,0	14,8	15,5	16,2	16,9	17,5	18,1	18,7	19,3	19,9	20,4	20,9	21,5
..07	1,60	7,1	8,7	10,1	11,3	12,4	13,3	14,3	15,1	15,9	16,7	17,5	18,2	18,9	19,5	20,2	20,8	21,4	22,0	22,6	23,1
..075	1,65	7,6	9,4	10,8	12,1	13,2	14,3	15,3	16,2	17,1	17,9	18,7	19,5	20,2	20,9	21,6	22,3	22,9	23,6	24,2	24,8
..08	1,70	8,2	10,0	11,5	12,9	14,1	15,2	16,3	17,3	18,2	19,1	20,0	20,8	21,6	22,3	23,1	23,8	24,5	25,1	25,8	26,4
..085	1,75	8,7	10,6	12,2	13,7	15,0	16,2	17,3	18,4	19,4	20,3	21,2	22,1	22,9	23,7	24,5	25,2	26,0	26,7	27,4	28,1
..09	1,80	9,2	11,2	13,0	14,5	15,9	17,2	18,3	19,5	20,5	21,5	22,5	23,4	24,3	25,1	25,9	26,7	27,5	28,3	29,0	29,7
..095	1,85	9,7	11,9	13,7	15,3	16,8	18,1	19,4	20,5	21,6	22,7	23,7	24,7	25,6	26,5	27,4	28,2	29,0	29,8	30,6	31,4
..10	1,90	10,2	12,5	14,4	16,1	17,6	19,1	20,4	21,6	22,8	23,9	25,0	26,0	27,0	27,9	28,8	29,7	30,6	31,4	32,2	33,0
..11	1,98	11,2	13,7	15,9	17,7	19,4	21,0	22,4	23,8	25,1	26,3	27,5	28,6	29,7	30,7	31,7	32,7	33,6	34,5	35,4	36,3
..12	2,08	12,2	15,0	17,3	19,3	21,2	22,9	24,5	25,9	27,3	28,7	29,9	31,2	32,3	33,5	34,6	35,6	36,7	37,7	38,7	39,6
..125	2,13	12,7	15,6	18,0	20,1	22,1	23,8	25,5	27,0	28,5	29,9	31,2	32,5	33,7	34,9	36,0	37,1	38,2	39,3	40,3	41,3
..13	2,16	13,2	16,2	18,7	20,9	22,9	24,8	26,5	28,1	29,6	31,1	32,4	33,8	35,0	36,3	37,5	38,6	39,7	40,8	41,9	42,9
..14	2,26	14,3	17,5	20,2	22,6	24,7	26,7	28,5	30,3	31,9	33,5	34,9	36,4	37,7	39,1	40,3	41,6	42,8	44,0	45,1	46,2
..15	2,34	15,3	18,7	21,6	24,2	26,5	28,6	30,6	32,4	34,2	35,8	37,4	39,0	40,4	41,9	43,2	44,6	45,8	47,1	48,3	49,5
..16	2,41	16,3	20,0	23,1	25,8	28,2	30,5	32,6	34,6	36,5	38,2	39,9	41,6	43,1	44,6	46,1	47,5	48,9	50,2	51,6	52,8
..18	2,54	18,3	22,5	25,9	29,0	31,8	34,3	36,7	38,9	41,0	43,0	44,9	46,8	48,5	50,2	51,9	53,5	55,0	56,5	58,0	59,4
..20	2,69	20,4	25,0	28,8	32,2	35,3	38,1	40,8	43,2	45,6	47,8	49,9	52,0	53,9	55,8	57,6	59,4	61,1	62,8	64,4	66,0
..25	2,99	25,5	31,2	36,0	40,3	44,1	47,7	50,9	54,0	57,0	59,7	62,4	64,9	67,4	69,8	72,0	74,3	76,4	78,5	80,6	82,5
..30	3,30	30,6	37,4	43,2	48,3	52,9	57,2	61,1	64,8	68,3	71,7	74,9	77,9	80,9	83,7	86,5	89,1	91,7	94,2	96,7	99,0
..40	3,80	40,8	49,9	57,6	64,4	70,6	76,2	81,5	86,5	91,1	95,6	99,8	103,9	107,8	111,6	115,3	118,8	122,3	125,6	128,9	132,1
..50	4,20	50,9	62,4	72,0	80,6	88,2	95,3	101,9	108,1	113,9	119,5	124,8	129,9	134,8	139,5	144,1	148,5	152,8	157,0	161,1	165,1
..60	4,70	61,1	74,9	86,5	96,7	105,9	114,4	122,3	129,7	136,7	143,4	149,7	155,9	161,7	167,4	172,9	178,2	183,4	188,4	193,3	198,1

Nozzle output must not exceed 90 ÷ 95% of pump's output • La portata dei getti non deve superare il 90 ÷ 95% della portata della pompa.



Nozzle	OUTPUT IN L/1' AT THE INDICATED PRESSURE • PORTATE IN L/1' ALLE PRESSIONI INDICATE																				
Type MEG	Ø mm	220	230	240	250	260	270	280	290	300	325	350	375	400	425	450	475	500	525	550	600
..015	0,80	5,1	5,2	5,3	5,4	5,5	5,6	5,7	5,8	5,9	6,2	6,4	6,6	6,8	7,0	7,2	7,4	7,6	7,8	8,0	8,4
..02	0,91	6,8	6,9	7,1	7,2	7,3	7,5	7,6	7,8	7,9	8,2	8,5	8,8	9,1	9,4	9,7	9,9	10,2	10,4	10,7	11,2
..025	1,00	8,4	8,6	8,8	9,0	9,2	9,4	9,5	9,7	9,9	10,3	10,7	11,0	11,4	11,7	12,1	12,4	12,7	13,1	13,4	14,0
..03	1,09	10,1	10,4	10,6	10,8	11,0	11,2	11,4	11,6	11,8	12,3	12,8	13,2	13,7	14,1	14,5	14,9	15,3	15,7	16,0	16,7
..035	1,12	11,8	12,1	12,4	12,6	12,9	13,1	13,3	13,6	13,8	14,4	14,9	15,4	15,9	16,4	16,9	17,4	17,8	18,3	18,7	19,5
..04	1,19	13,5	13,8	14,1	14,4	14,7	15,0	15,2	15,5	15,8	16,4	17,0	17,6	18,2	18,8	19,3	19,9	20,4	20,9	21,4	22,3
..045	1,27	15,2	15,5	15,9	16,2	16,5	16,8	17,2	17,5	17,8	18,5	19,2	19,9	20,5	21,1	21,7	22,3	22,9	23,5	24,0	25,1
..05	1,35	16,9	17,3	17,6	18,0	18,4	18,7	19,1	19,4	19,7	20,5	21,3	22,1	22,8	23,5	24,2	24,8	25,5	26,1	26,7	27,9
..055	1,40	18,6	19,0	19,4	19,8	20,2	20,6	21,0	21,3	21,7	22,6	23,4	24,3	25,1	25,8	26,6	27,3	28,0	28,7	29,4	30,7
..06	1,47	20,3	20,7	21,2	21,6	22,0	22,5	22,9	23,3	23,7	24,6	25,6	26,5	27,3	28,2	29,0	29,8	30,6	31,3	32,1	33,5
..065	1,52	22,0	22,5	22,9	23,4	23,9	24,3	24,8	25,2	25,6	26,7	27,7	28,7	29,6	30,5	31,4	32,3	33,1	33,9	34,7	36,3
..07	1,60	23,7	24,2	24,7	25,2	25,7	26,2	26,7	27,2	27,6	28,8	29,8	30,9	31,9	32,9	33,8	34,8	35,7	36,5	37,4	39,1
..075	1,65	25,3	25,9	26,5	27,0	27,6	28,1	28,6	29,1	29,6	30,8	32,0	33,1	34,2	35,2	36,2	37,2	38,2	39,2	40,1	41,9
..08	1,70	27,0	27,6	28,2	28,8	29,4	29,9	30,5	31,0	31,6	32,9	34,1	35,3	36,5	37,6	38,7	39,7	40,8	41,8	42,7	44,6
..085	1,75	28,7	29,4	30,0	30,6	31,2	31,8	32,4	33,0	33,5	34,9	36,2	37,5	38,7	39,9	41,1	42,2	43,3	44,4	45,4	47,4
..09	1,80	30,4	31,1	31,8	32,4	33,1	33,7	34,3	34,9	35,5	37,0	38,4	39,7	41,0	42,3	43,5	44,7	45,8	47,0	48,1	50,2
..095	1,85	32,1	32,8	33,5	34,2	34,9	35,6	36,2	36,9	37,5	39,0	40,5	41,9	43,3	44,6	45,9	47,2	48,4	49,6	50,8	53,0
..10	1,90	33,8	34,6	35,3	36,0	36,7	37,4	38,1	38,8	39,5	41,1	42,6	44,1	45,6	47,0	48,3	49,7	50,9	52,2	53,4	55,8
..11	1,98	37,2	38,0	38,8	39,6	40,4	41,2	41,9	42,7	43,4	45,2	46,9	48,5	50,1	51,7	53,2	54,6	56,0	57,4	58,8	61,4
..12	2,08	40,6	41,5	42,4	43,2	44,1	44,9	45,7	46,6	47,4	49,3	51,1	52,9	54,7	56,4	58,0	59,6	61,1	62,6	64,1	67,0
..125	2,13	42,2	43,2	44,1	45,0	45,9	46,8	47,7	48,5	49,3	51,3	53,3	55,1	57,0	58,7	60,4	62,1	63,7	65,3	66,8	69,8
..13	2,16	43,9	44,9	45,9	46,8	47,8	48,7	49,6	50,4	51,3	53,4	55,4	57,4	59,2	61,1	62,8	64,6	66,2	67,9	69,5	72,5
..14	2,26	47,3	48,4	49,4	50,4	51,4	52,4	53,4	54,3	55,2	57,5	59,7	61,8	63,8	65,8	67,7	69,5	71,3	73,1	74,8	78,1
..15	2,34	50,7	51,8	52,9	54,0	55,1	56,2	57,2	58,2	59,2	61,6	63,9	66,2	68,3	70,5	72,5	74,5	76,4	78,3	80,1	83,7
..16	2,41	54,1	55,3	56,5	57,6	58,8	59,9	61,0	62,1	63,1	65,7	68,2	70,6	72,9	75,1	77,3	79,4	81,5	83,5	85,5	89,3
..18	2,54	60,8	62,2	63,5	64,8	66,1	67,4	68,6	69,8	71,0	73,9	76,7	79,4	82,0	84,5	87,0	89,4	91,7	94,0	96,2	100,5
..20	2,69	67,6	69,1	70,6	72,0	73,5	74,9	76,2	77,6	78,9	82,1	85,2	88,2	91,1	93,9	96,7	99,3	101,9	104,4	106,9	111,6
..25	2,99	84,5	86,4	88,2	90,1	91,8	93,6	95,3	97,0	98,7	102,7	106,6	110,3	113,9	117,4	120,8	124,1	127,4	130,5	133,6	139,5
..30	3,30	101,4	103,7	105,9	108,1	110,2	112,3	114,4	116,4	118,4	123,2	127,9	132,4	136,7	140,9	145,0	149,0	152,8	156,6	160,3	167,4
..40	3,80	135,2	138,2	141,2	144,1	146,9	149,7	152,5	155,2	157,8	164,3	170,5	176,5	182,3	187,9	193,3	198,6	203,8	208,8	213,7	223,2
..50	4,20	169,0	172,8	176,5	180,1	183,7	187,2	190,6	194,0	197,3	205,4	213,1	220,6	227,8	234,8	241,7	248,3	254,7	261,0	267,2	279,0
..60	4,70	202,8	207,3	211,8	216,1	220,4	224,6	228,7	232,8	236,8	246,4	255,7	264,7	273,4	281,8	290,0	297,9	305,7	313,2	320,6	334,8

Nozzle output must not exceed 90 ÷ 95% of pump's output • La portata dei getti non deve superare il 90 ÷ 95% della portata della pompa.



**ANNOVI[®]
REVERBERI
GROUP**

Modena - ITALY
Bomporto - ITALY



**ANNOVI[®]
REVERBERI**
The Power of Experience

Shanghai - CINA



**PERFORMANCE
PUMP**
上海艾热性能泵有限公司

Shanghai - CINA



CHINA[®]
艾热中国

Minneapolis - USA



**NORTH
AMERICA**

Curitiba - BRAZIL



**LATIN
AMERICA**

Memphis - USA



Bomporto - ITALY



Motteggiana - ITALY



Cavallirio - ITALY



Formigine - ITALY



Castelfranco Emilia - ITALY



Reggio Emilia - ITALY



Reggio Emilia - ITALY





Ace Pumps offre una linea completa di pompe centrifughe per svariate applicazioni industriali.

Versioni:

- Motore Idraulico
- PTO
- Trasmissione a cinghia
- Motore a scoppio
- Pressioni fino a 11 bar (160 psi)

Applicazioni:

Agricoltura, Deicing, Municipalità, Cantieri ed edilizia, Industria mineraria, Antincendio, Abbattimento polveri

Ace Pumps offers a complete line of centrifugal pumps for mobile applications:

Versions:

- Hydraulic Driven
- PTO
- Belt Driven
- Gasoline Engine Driven
- Pressure up to 11 bar (160 psi)

Applications:

Agriculture, Deicing, Municipality, Construction sites and building, Mining industry, Firefighting, Dust suppression

Valvolmeccanica

LANCE AD ALTA PRESSIONE E COMPONENTI Spray guns and parts



Valvolmeccanica è stata fondata nel 1974 come piccola officina per la produzione di accessori per l'irrorazione e la protezione delle colture. L'azienda ha sviluppato una propria linea di prodotti che comprendono getti, ugelli, gruppi di comando, lance, filtri e altri accessori per l'irrorazione. Certificata UNI EN ISO 9001:2015, dal 2017 fa parte del Gruppo Annovi Reverberi. Nel 2024 ha acquisito il ramo agricoltura di BS System, ampliando la propria offerta di soluzioni per migliorare l'efficienza dei trattamenti in agricoltura.

Valvolmeccanica was founded in 1974 as a small workshop for the production of accessories for spraying and crop protection. The company has developed its own line of products that include jets, nozzles, control units, lances, filters and other accessories for spraying. Certified UNI EN ISO 9001:2015, since 2017 it has been part of the Annovi Reverberi Group. In 2024 it acquired the agriculture branch of BS System, expanding its offer of solutions to improve the efficiency of treatments in agriculture.





Ravel

MOTORI ELETTRICI Electric motors



RT Series



RV Series



Rsf Series

Il nuovo motore elettrico Ravel con giunto interno è la soluzione ideale per l'accoppiamento tra pompa alta pressione e motore.

Ha le dimensioni di ingombro ridotte proprie della versione motore albero cavo mantenendo però tutti i vantaggi tecnici e di manutenzione del motore standard con campana e giunto.

Nella parte anteriore è dotato di scudo e flangia: il primo, provvisto di cuscinetto, protegge l'interno del motore mentre la seconda sostiene la pompa e contiene il giunto elastico.

Nuovo design, la qualità Ravel di sempre.

The new Ravel electric motor with internal joint is the ideal way to couple high pressure pump to the motor.

It has reduced overall dimensions of hollow shaft motor while keeping all the technical and maintenance advantages of standard motor with bell housing and flexible joint.

It has the shield and flange on front side: the first, equipped with bearing, protects the inside motor while the second supports the pump and contains the flexible joint.

New design, same high Ravel quality.

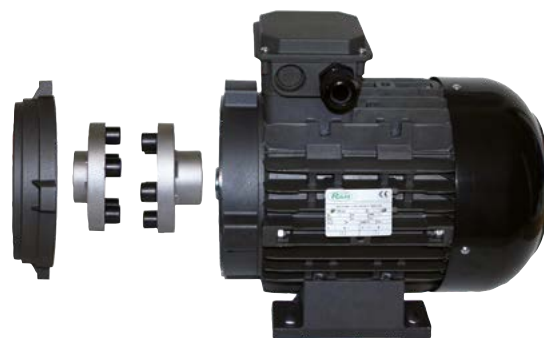

RVJ Series

Ghirri

MOTORIDUTTORI Gearboxes



G.M. Ghirri Motoriduttori progetta e realizza riduttori speciali di piccole e medie dimensioni.

Partendo dalla richiesta del cliente, grazie alla struttura particolarmente flessibile e alla grande professionalità dei propri progettisti, G.M. è in grado di sviluppare qualsiasi tipo di riduttore speciale.

L'alto grado di know-how, l'utilizzo dei software più recenti e il lavoro dell'ufficio tecnico in stretta collaborazione con il committente, permettono di realizzare la perfetta integrazione del riduttore nella macchina del cliente.

G.M. Ghirri Motoriduttori designs and manufactures small and medium-sized special reducers.

Starting from the customer's request, thanks to the particularly flexible structure and the great professionalism of its designers, G.M. is able to develop any type of special reducer. The high level of know-how, the use of the most recent software and the work of the technical office in close collaboration with the customer, allow the perfect integration of the reducer into the customer's machine.

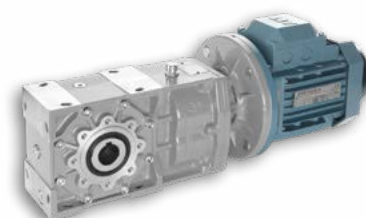

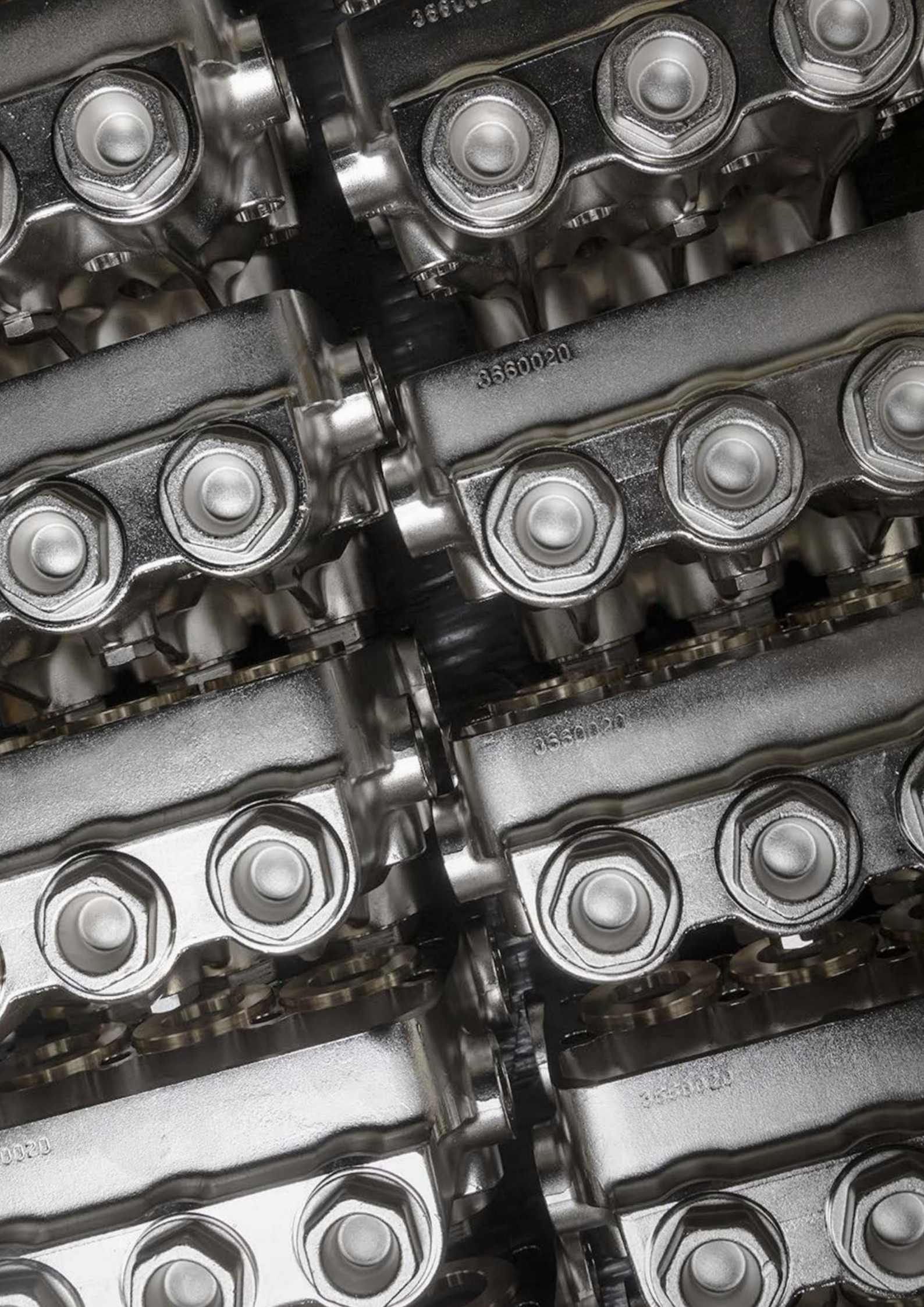

3660020

3660020

3660020

3660020

0020





Applicazioni Applications



lavaggio industriale
industrial cleaning



idropultrici
pressure washers



processi industriali
industrial processes



autolavaggio
car wash



produzione
manufacturing



agricoltura
agriculture



industria alimentare
food industry



municipality

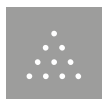

misting



pulizia tubazioni
sewer jetting



cantieri ed edilizia
construction industry



settore navale
marine industry



antincendio
fire fighting



atomizzatori
atomizers



deicing
deicing



antincendio
fire-fighting

Tecniche Technical



pressione massima
max pressure



flusso massimo
max flow rate



RPM



potenza assorbita
absorbed power



temperatura
temperature



peso netto
net weight



frequenza motore
motor frequency

Core



testa in ottone
brass head



testa in alluminio
aluminium head



testa nichelata
nickel plated head



testa in inox
inox head



bielle in bronzo
bronze connecting-rods



bielle in alluminio
aluminium connecting-rods



O-Ring in Viton
Viton O-Rings



motore a scoppio
gasoline engine



motore elettrico
electric engine



motore idraulico
hydraulic drive



guarnizioni in PTFE
PTFE gasket sealing



TSS[®]
Total Stop SYSTEM



TST[®]
Total Stop SYSTEM TIMED

Generiche Generic

NEW

novità
new

Il presente catalogo annulla e sostituisce tutti i precedenti, può essere modificato senza alcun preavviso. Annovi Reverberi S.p.A. si riserva la facoltà di effettuare consegne parziali. Dati, descrizioni ed illustrazioni sono forniti a titolo indicativo e non impegnativo.

This catalogue cancels all previous ones and can be modified without notice. Annovi Reverberi S.p.A. preserves the right to carry out partial shipments. Characteristics and descriptions are not binding



ANNOVI[®]
REVERBERI
The Power of Experience

Seguici su / Follow us on



Annovi Reverberi spa

Via Martin Luther King 3
41122 Modena (Italy)
Tel +39 059 414 411
Fax +39 059 253 505
infoar@annovireverberi.it
www.annovireverberi.it

AR North America Inc.

140 - 81st Avenue Northeast
Fridley, MN USA 55432
Ph. +1 763 398 2008
Fax +1 763 398 2009
info@arnorthamerica.com
www.arnorthamerica.com

AR China Distribution Co., Ltd

2nd Floor, Build. 1, No. 651 Jiangting Rd.
Jinhui Town, Fengxian District, Shanghai
201404 China
Ph./Fax. +86 21 54846800 ext 815
info@ar-china.cn
www.ar-china.cn

AR Latin America

Rua Jandaia do Sul 125, Pinhais
Curitiba, Brasil, CEP 83324-440
Ph. +55 41 3059-2748
info@arlatam.com.br
www.annovireverberi.com.br
www.arlatam.com.br